

Apple Service
Technical Procedures
Apple II Family
Volume One

 Apple Technical Procedures

APPLE II FAMILY

SERVICE NOTICE

**APPLE II FAMILY
TECHNICAL PROCEDURES MANUALS – P/N 072-0229**

Apple IIe – The Troubleshooting section now contains information about what to do when the computer does not auto boot with UniDisk or Profile.

🍏 Apple Technical Procedures

SERVICE NOTICE

A Final Farewell to the Technical Procedures

This is the **final mailing** of the Technical Procedures. For many years Apple has provided you with service documentation in familiar three-ring binders. But each year, as Apple introduces new products, the number of volumes grows, and the time you spend updating the Technical Procedures increases. The many volumes of service documentation are on the verge of becoming unmanageable.

To alleviate this problem, beginning in mid-June, Apple will provide service documentation through *Service Source*—a CD-based format that requires no updating.

So, with this mailing we say "Good-bye" to the familiar blue-and-white binders. We're sure that you'll be as pleased with the new approach as we are.

🍏 Apple Technical Procedures

Apple II Family

Document Control

March 1992

TECHNICAL PROCEDURES FILING INSTRUCTIONS

	REMOVE PAGES	INSERT PAGES
APPLE II FAMILY - VOLUME ONE		
VOLUME Table of Contents	1 page	1 page
Apple IIe	3.7	3.7

Please store this Document Control Sheet behind the Table of Contents at the front of the manual.

Note: All Technical Procedures changes are highlighted by a double line || in the outside margins.

Apple Service Technical Procedures Apple II Family

Volume One

PN: 072-0229

🍏 Apple Technical Procedures

Apple II Family Volume One

Table of Contents

	--Title page (contains build date)	--
Apple IIe	--Table of Contents	05/89
	--Service Notes	09/86
	(except pages 0.5, 0.7)	08/87
	(except page 0.6)	06/87
	--Take-Apart	09/82
	(except pages 1.1,1.5,1.6,1.7,1.9)	06/85
	(except pages 1.4, 1.8, 1.10)	10/83
	--Diagnostics	07/88
	--Troubleshooting	10/88
	(except page 3.7)	03/92
	--Theory of Operations Overview--TS Appendix	05/86
	--Additional Procedures	07/87
	--Illustrated Parts List	05/89
	--Apple II Memory Expansion Card	12/85
	(except pages 6.1, 6.4)	02/87
	(except page 6.6)	01/86
	--Appendix A	11/91
	--Appendix B	02/87
Apple IIc	--Table of Contents	07/87
	--Basics	10/86
	(except pages 1.1, 1.12, 1.13)	01/87
	(except page 1.4)	10/90
	--Take-Apart	10/86
	(except pages 2.1, 2.3, 2.6, 2.7, 2.17-2.20)	01/87
	--Preventive Maintenance	10/86
	--Diagnostics	05/87
	--Troubleshooting	10/86
	(except pages 5.3, 5.4)	01/87
	--Additional Procedures	10/86
	(except pages 6.1, 6.20, 6.21)	10/87
	(except pages 6.2-6.4, 6.9)	01/87
	(except pages 6.5-6.8)	02/87
	(except pages 6.11, 6.16)	03/87
	(except page 6.17)	12/86
	(except page 6.10)	08/91

**Apple IIc
(Cont'd)**

--Adjustments	07/87
--Illustrated Parts List	07/87
(except page IPL.2)	10/87
(except page IPL.3)	12/88

Apple IIgs

--Table of Contents	04/90
--Basics	08/89
--Take-Apart	10/86
(except page 2.5)	11/86
(except page 2.8)	09/88
(except page 2.11)	12/87
--Diagnostics	08/89
(except pages 3.11, 3.12)	06/90
--Troubleshooting	10/86
(except page 4.1)	04/90
(except pages 4.5-4.8)	06/90
--Additional Procedures	08/89
(except page 5.1)	10/89
(except pages 5.5, 5.11-5.19)	04/90
(except pages 5.8, 5.9)	05/91
(except page 5.10)	11/91
--Illustrated Parts List	10/86
(except page IPL.1)	02/87
(except page IPL.12)	10/87
(except page IPL.9)	02/89
(except pages IPL.4)	10/89
(except page IPL.3)	04/90
(except page IPL.5)	05/91
(except page IPL.13)	07/91
(except page IPL.7)	11/91

Apple IIc Plus

--Table of Contents	03/89
--Basics	10/88
(except page 1.4)	03/89
(except page 1.2)	04/89
--Take-Apart	03/89
(except pages 2.2-2.5)	10/88
--Diagnostics	10/88
--Troubleshooting	10/88
--Illustrated Parts List	10/88

🍏 Apple Technical Procedures

Apple IIe

Technical Procedures

□ TABLE OF CONTENTS

Section 0 – Apple IIe Service Notes	0.3	Identification – Rev. A, Rev. B, and Enhanced
	0.4	Exchanges of Old Revision A Logic Boards
	0.5	Compatibility of ProFile Interface Cards
	0.5	Case and Keyboard Changes
	0.5	Power Supply Change
Section 1 – Take-Apart	1.4	Opening the Case
	1.5	Removing and Replacing Peripheral Cards and Disk Drive Cables
	1.7	Removing and Replacing the Housing
	1.10	Removing and Replacing the Motherboard
	1.11	Removing and Replacing the Keyboard
	1.12	Removing and Replacing the Power Supply
Section 2 – Diagnostics	2.2	Introduction
	2.2	General Information
	2.2	Before You Start
	2.2	Built-In Diagnostics
	2.3	Things To Remember
	2.5	Apple II Diagnostic Diskette
	2.5	Materials Required
	2.5	Main Menu
	2.6	Choose Tests
	2.8	Options
	2.8	Special
	2.9	Running the Diagnostic
2.12	Test Failures	
Section 3 – Troubleshooting	3.2	Introduction
	3.2	General Information
	3.2	Before You Start
	3.2	How to Use the Symptom Charts
	3.3	Things to Remember
	3.3	Logical Troubleshooting
	3.4	Modules and Functions
	3.6	Apple IIe Symptom Chart

**Section 4 –
Additional Procedures**

- 4.3 Apple IIe Enhancement Kit Upgrade
- 4.6 Single-Wire Shift-Key Modification

**Section 5 –
Illustrated
Parts List**

- IPL.3 Finished Goods Assembly, Beige
- IPL.5 Platinum Case and Extended Keyboard
- IPL.7 Logic Board
- IPL.7 Power Supply Switch
- IPL.9 Power Supply
- IPL.9 Spacebar Stabilizer Assembly

**Section 6 –
Memory Expansion
Card**

- 6.3 Introduction
- 6.4 Things to Remember
- 6.6 Diagnostics and Troubleshooting

Appendix A –

- A.1 Keyboard and Keyswitch Identification

Appendix B –

- B.1 Apple II Plus and Apple IIe: Differences

©Apple Computer, Inc., 1985-1989. No portion of this document may be reproduced in any form without the written permission of Apple Computer, Inc.

UniDisk is a trademark of Apple Computer, Inc.

ProDOS, DuoDisk, Disk II, Apple, and the Apple logo are registered trademarks of Apple Computer, Inc.

Apple IIe Technical Procedures

Section 0

Apple IIe Service Notes

Contents:

Identification - Rev. A, Rev. B, and Enhanced.....	0.6
Exchanges of Old Revision A Logic Boards.....	0.6
Compatibility of ProFile Interface Cards.....	0.7
Case and Keyboard Changes.....	0.7
Power Supply Change.....	0.7

IDENTIFICATION - REV. A, REV. B, AND ENHANCED

If the Apple IIe contains a Rev. A unenhanced logic board, it MUST be upgraded to a Rev. B unenhanced BEFORE the Apple IIe Enhancement Kit can be installed.

Use the following chart to identify what version of the Apple IIe logic board the customer has.

	Rev. A	Rev. B	Enhanced
Manufacturing Number (last two digits and revision letter)	64-A	64-B	87-A
Microprocessor at B4	6502	6502	65C02
Date on the board	1982	1982	1984
Heading at top of of monitor on power up	Apple II	Apple II	Apple IIe

See **Section 4 - Other Procedures** for more information on what this enhancement does.

EXCHANGES OF OLD REVISION A LOGIC BOARDS

Apple has been upgrading Apple IIe Logic - Rev. A (1982) logic boards with Rev. B logic boards over the last year. Apple's supply of Rev. A boards was recently sold in bulk to Value Added Resellers (VARs). The VARs purchased the boards "as is," under the condition they would assume complete responsibility for support of the product.

Each Rev. A logic board that was sold to a VAR can be recognized by the following markings:

Component Side: "VAR" is stamped on the right-hand upper third of the board, just below the expansion slots.

Solder Side: "VAR" is stamped in the left-hand lower corner of the logic board.

The Rev. A logic boards with the VAR stamp are not eligible for Apple's exchange module program.

COMPATIBILITY OF PROFILE INTERFACE CARDS

Apple IIe ProFile Interface Cards, which are service stock inventory, may require a chip change to make them compatible with both 5 and 10 MB ProFiles. The interface cards containing EPROM 342-0271 at location D2716-1 only work with the 5 MB ProFiles. If a 10 MB ProFile is to be used, the EPROM should be replaced with EPROM 342-0299.

CASE AND KEYBOARD CHANGES

The Apple IIe has had some minor changes made. They are now being shipped with a platinum case and the Apple IIe Extended Keyboard (the keypad is built-in). There were no major changes made to the logic board circuitry so it is fully compatible with all previous logic boards.

POWER SUPPLY CHANGE

There is a new power supply that is 1.5" longer than the other model. This power supply is fully interchangeable with all previous IIe power supplies and may be used in any Apple IIe system.

NOTE: Although this power supply is similar to that shipped in the Apple IIGS, the two power supplies are not interchangeable.

Apple IIe Technical Procedures

Section 1

Take-Apart

Contents:

Opening and Replacing the case.....	1.2
Removing and Replacing Peripheral Cards and Disk Drive Cables.....	1.2
Removing and Replacing the Housing.....	1.5
Removing and Replacing the Motherboard.....	1.8
Removing and Replacing the Keyboard.....	1.9
Removing and Replacing the Power Supply.....	1.10

Note: Different versions (revisions) of the motherboard are mounted in different ways to the base. This module will show you only one mounting, but it should be easy to adjust to the others. All other instructions apply to all revisions of the motherboard.

There are also differences between the backplates. The later Apple IIe's do not require clamps for the disk drive cables or nutplates for the DB connectors.

The keyboard is attached to the upper housing in the new version of the Apple IIe case. (In earlier versions, the keyboard is attached to the base.)

For these procedures you will need:

Phillips head screwdriver
Flat blade screwdriver
Wrench (p/n 919-0007)

A. OPENING THE CASE

1. Power down and disconnect the power cord.
2. Remove Apple lid.
3. Touch the power supply to release any static build-up.

3. REMOVING AND REPLACING PERIPHERAL CARDS AND DISK DRIVE CABLES

Removing Peripheral Cards and Disk Drive Cables

1. Remove the disk interface card from slot 6.
2. Unplug the disk drive cable connectors from the interface card.
3. To remove the disk drive cable from the back panel, remove the two Jack screws from the clamp (See Figure 1), slide the cable out of the clamp (See Figure 2), and pull the cable out of the opening in the back panel.

FIGURE 1

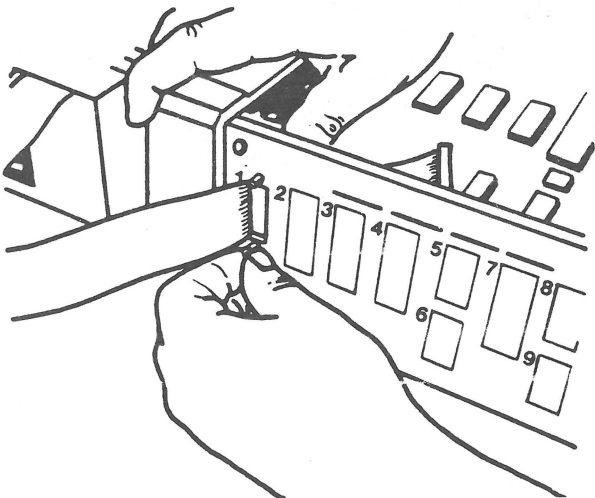
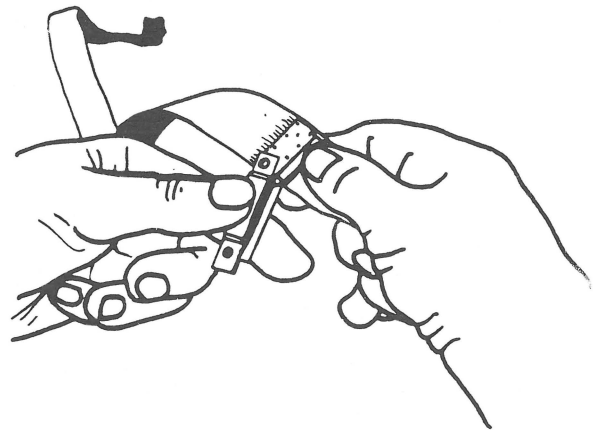

FIGURE 2



Replace Disk Drives Cables

1. Slide the disk drive's cable through the lowest numbered opening of the back of panel.
2. Take hold of the cable and bend the flap away from the connector. Hold the flap against the cable with your thumb.
3. Hold the clamp in your other hand so the side with the raised section is under your thumb and the opening in the clamp is pointing up (See Figure 3).

FIGURE 3

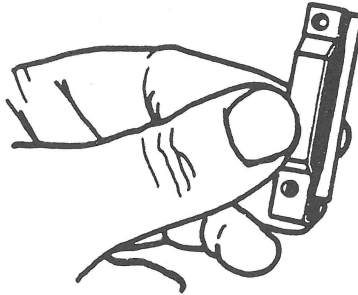

4. Slide the cable and folded over metal flap into the clamp so that the flap is pressed against the cable and sandwiched between the two sides of the clamp (See Figure 4).

NOTE: You may have to spread the clamp open slightly to make room for the flap.

FIGURE 4

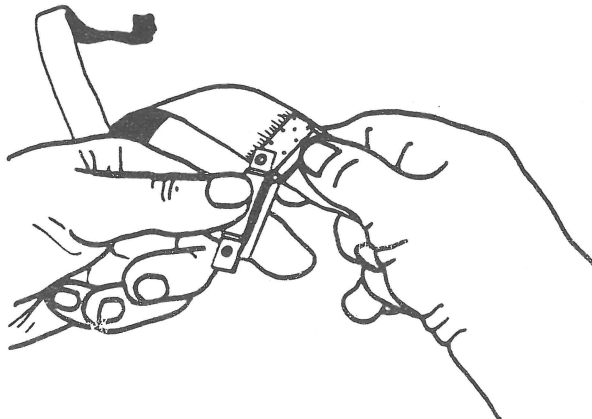

5. Feed the cable back through the opening until the clamp touches the back panel. Push the clamp against the back panel so that the raised section fills the opening and the two round nuts that are affixed to the clamp are facing you (See Figure 5).

NOTE: In order to arrange the clamp so it's flat against the back panel, you may have to bend the cable into an "L" shape at the drive side of the clamp.

FIGURE 5

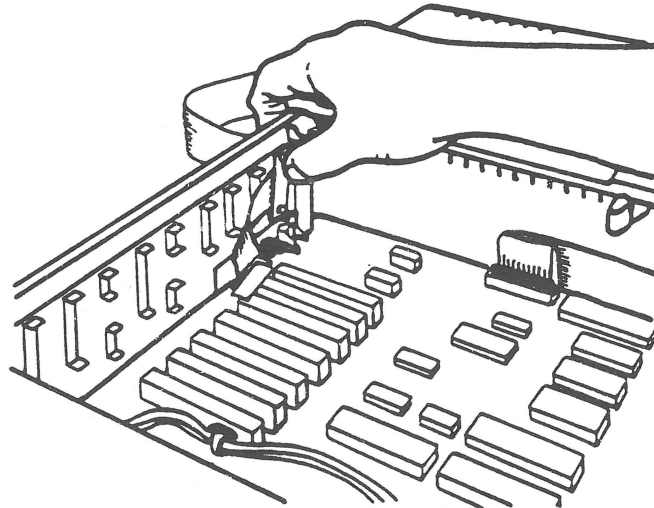

6. Hold the clamp against the opening with one hand. Reach behind the computer with the other hand and install the two screws through the two slots on the top and bottom of the opening and into the nuts on the clamp.
7. Plug the disk drive cable connectors into the interface card.
8. Insert the disk interface card into slot 6.

C. REMOVING AND REPLACING THE HOUSING

1. Open the case (Section A, p.1.2) and remove the peripheral cards and disk drive cables (Section B, p.1.2).

NOTE: On the new version of the Apple IIe case, the keyboard is attached to the upper housing (rather than to the base). Before the housing can be separated from the base, the keyboard ribbon cable must be disconnected from the motherboard.

2. Turn the Apple upside down resting the keyboard on a protective pad.
3. Remove the ten round head screws from the periphery of the base (See Figure 6, #1). (**Note:** The new Apple IIe case has only nine screws.)

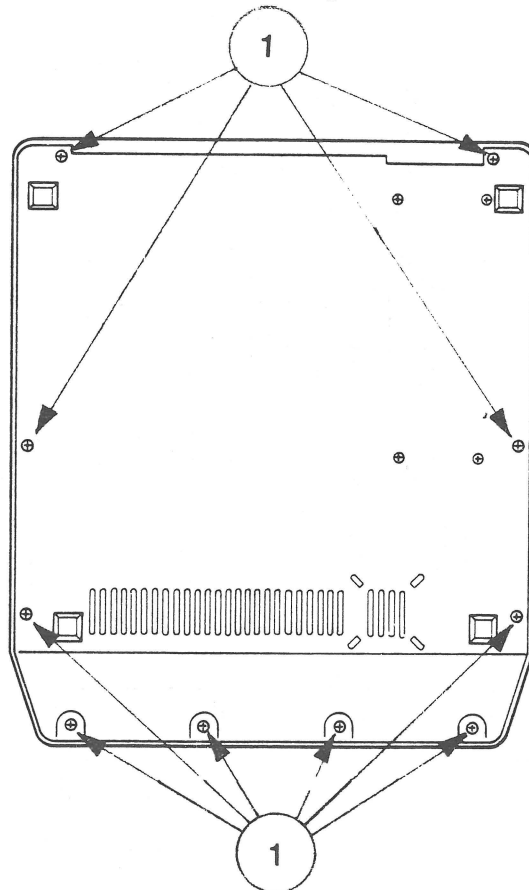

FIGURE 6

4. Turn the computer right side up.
5. Remove the two screws that are in the upper right and left corners of the back panel. (These two screws are absent in the new case.)

6. To free the housing on older versions, push back on the thin metal back plate until it is free from the horizontal bar which is part of the housing (See Figure 7, #1). Gently lift the housing off the base.

NOTE: In the new case, the metal back plate nests into the horizontal bar running across the back of the upper housing. Since the horizontal bar forms a cap over the back plate, the upper housing is freed by lifting straight up.

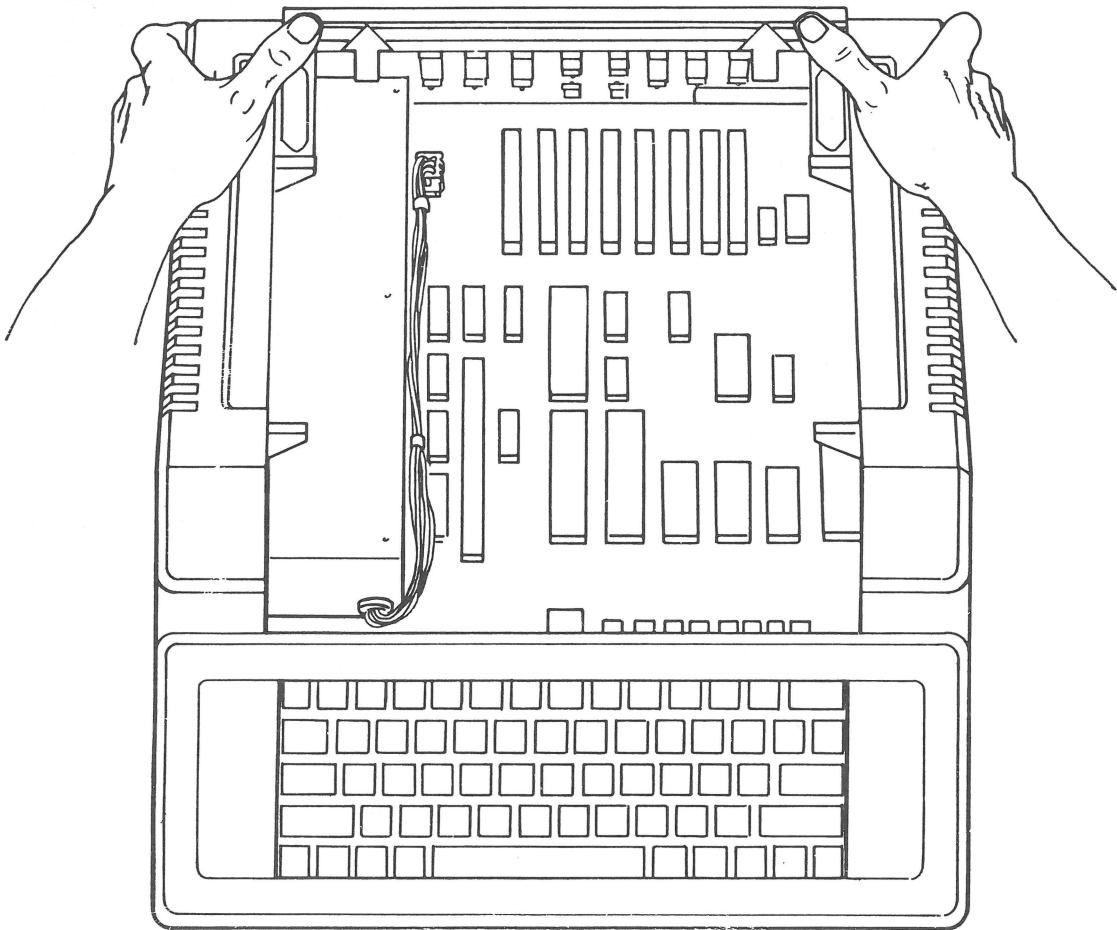

FIGURE 7

Replacing the Housing

1. Slide the housing over the base. For replacing older cases, flex the back metal plate backwards to ease it over the back plastic bar of the housing. It is not necessary to flex the metal back plate of the new case version -- simply settle the upper housing over the base, making sure the end of the keyboard ribbon cable is inside the case area.

NOTE: On the older case versions, be sure the keyboard cable remains in the box, is properly folded, and is lying flush against the outside of the keyboard stand. Also, be sure the keyboard sits freely in the housing. In particular, check the reset key to see that it does not stick after it has been pressed down.

2. Turn the computer upside down, resting the keyboard on the protective pad.
3. Replace the ten (or nine) screws that attach the housing to the base.

NOTE: When replacing the screws put in all of them partway, and then, starting from front to back, secure them tightly.

4. Turn the computer right side up.
5. For older case versions, replace the two screws in the upper left and right corners of the back panel.

D. REMOVING AND REPLACING THE MOTHERBOARD

Removing the Motherboard

1. Remove the housing from the Apple, (Section C, p.1.5).
2. Pinch the left and right sides of the power supply plug and pull the plug from the top of the motherboard. (See Figure 8, #1).
3. Unplug the speaker connector. (See Figure 8, #2).
4. Remove the keyboard cable. (See Figure 8, #3).
5. Remove the four screws across the back of the motherboard. (See Figure 8, #4).
6. Using a flat blade screwdriver push in on the flanges of the six stand-offs: three across the middle and three toward the front of the motherboard.
7. Carefully slide the board forward; then lift the board up and out.

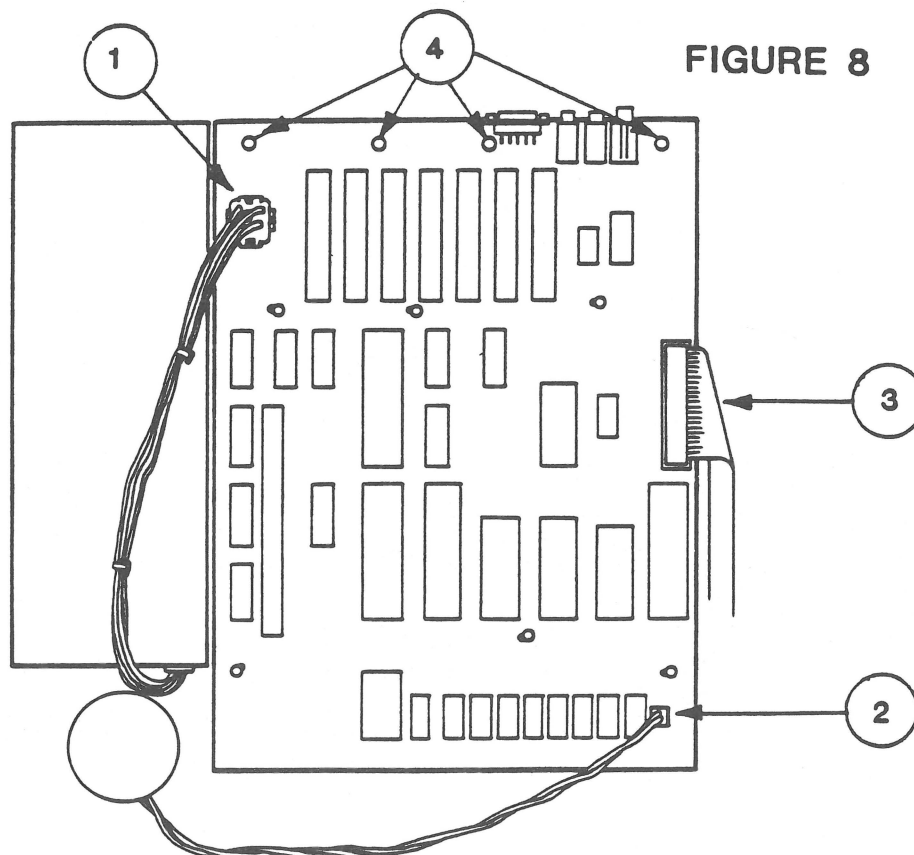

Replacing the Motherboard

NOTE: See "Section 0. Apple IIe Service Notes" for module exchange information on all Rev. A Logic Boards.

1. Place the motherboard over the six stand-offs and press the board down into place.
2. Replace the four screws across the back of the motherboard.
3. Plug in the speaker connector.
4. Plug in the power supply.
5. Plug in the keyboard cable.

E. REMOVING AND REPLACING THE KEYBOARD

Removing the Keyboard

1. Remove the housing from the Apple (Section C, p.1.5).
2. Remove the four Phillips head screws which hold the keyboard in place on the keyboard stand.

NOTE: In the new case version, the keyboard is attached by four Phillips screws to the upper housing, rather than to a keyboard stand on housing base plate.

3. Lift the keyboard free.

Replacing the Keyboard

1. For older case versions, place the keyboard on the keyboard stand. For the new case version, set the keyboard in the upper housing.
2. Replace the four screws to attach the keyboard to the stand (or, in the new version, to the upper housing).

F. REMOVING AND REPLACING THE POWER SUPPLY

Removing the Power Supply

1. Open the Apple case (Section A, p. 1.2).
2. Unplug the power supply from the motherboard.
3. Set the base on its side.
4. While steadying the base and power supply with one hand remove the four screws with lock washers from the base.
5. Remove base from power supply.

Replacing the Power Supply

1. Align power supply with base.
2. Replace the four round head screws with washers.
3. Turn the base right side up.

Apple IIe

Section 2 – Diagnostics

□ CONTENTS

2.2	Introduction
2.2	General Information
2.2	Before You Start
2.2	Built-In Diagnostics
2.3	Things To Remember
2.5	Apple II Diagnostic Diskette
2.5	Materials Required
2.5	Main Menu
2.6	Choose Tests
2.8	Options
2.8	Special
2.9	Running the Diagnostic
2.12	Test Failures

□ INTRODUCTION

General Information

This section describes general procedures for using the 3.5- or the 5.25-inch *Apple II Diagnostic* diskette on the Apple IIe. This diagnostic allows you to select the tests you wish to run and the order in which you wish to run them. It also allows you to run a continuous test and keep a record of any error codes that may occur. This record will prove valuable for pinpointing problems that cause intermittent failures.

Note: On the unenhanced IIe, this diskette will produce strange characters and screens, due to the use of MouseText in the programming of the diagnostic.

Before You Start

Read *Things to Remember* before you run the diagnostics. It will give you specific hints for using the diagnostic.

Built-In Diagnostics

Before attempting to boot the diskette-based diagnostics, run the built-in diagnostics. To run them, hold down the <Open-Apple> and <Closed-Apple> keys while turning on the power. (To run the built-in diagnostics if the power is already on, hold down <Control>, <Open-Apple>, <Closed-Apple>, and <Reset>. Release <Reset> first, then the other keys.)

The screen will display various patterns for approximately one minute. The RAM, ROM, and other components on the logic board are being tested.

Results

The results are displayed in the lower left corner of the screen. "System Good" is accompanied by a high-toned beep, "System Bad" by a low-toned beep.

System Good

If you can access the built-in diagnostics and you receive the message "System Good," connect a disk drive and continue with this section.

System Bad

If you cannot access the built-in diagnostics or if you receive the message "System Bad," exchange the keyboard or logic board and try again.

□ THINGS TO REMEMBER

1. Make a backup diskette before beginning! When testing a defective Apple IIe, it is possible to erase and/or damage a section of the diskette. The *System Utilities* diskette (rev. 2.1 or higher) is used for making a backup copy. Follow the instructions in the *System Utilities Manual*.
2. When loading or saving selected test sequences to diskette, use only a known-good system and disk drive.
3. Where input is required to start the next test (after video test, for example), press <Spacebar>. If you press <Escape>, the testing will stop.
4. The standard keyboard is automatically selected on power up. If you have the extended keyboard, you must select it.
5. To abort the keyboard test, hold down <Control> and press c.
6. To make a selection, type the letter of the test or use the arrow keys until the selection is highlighted, and then press <Return>.
7. When chosen, the tests display a number (1, 2, 3, etc.). This number indicates the order in which the tests will be performed.
8. To deselect a test, type the letter of the test or use the arrow keys until the selection is highlighted; then press the <Delete> key. The numbers displayed will be corrected automatically. To deselect all tests, hold down <Open-Apple> and press <Delete>.
9. To access the Help screen, hold down <Open-Apple> and <Shift>, and press ?.
10. For information on testing the Memory Expansion Card, refer to Section 6, Apple II Memory Expansion Card.

11. If you attempt to run the Disk Card Test using a write-protected diskette, the testing will stop and an error message will be displayed. If this occurs, write-enable the diskette, reboot the Apple IIe diagnostic, and rerun the Disk Card Test.
12. When running the Character Generator Test and using a ColorMonitor IIe or Composite Monitor IIe, the video display shifts left and right and toggles between color and monochrome. (This is the normal result of the method used to display the Character Set Test.)

To make the display easier to view, depress the White-Only switch during the Character Generator Test, and release the switch during all other tests.

□ APPLE II DIAGNOSTIC DISKETTE

Materials Required

Apple II Diagnostic diskette (5.25- or 3.5-inch)
Extended 80-Column Card
Known-good 5.25- or 3.5-inch disk drive (DuoDisk,
Disk II, UniDisk/Apple 5.25 Drive, or UniDisk 3.5)
Apple IIe (enhanced or unenhanced)

Main Menu

The *Apple II Diagnostic* diskette main menu is shown below.

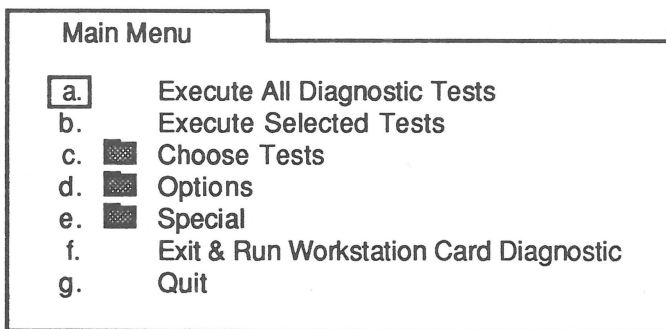

The following list describes each item in the main menu:

Execute All Diagnostic Tests - Runs the standard Apple IIe test sequence.

Execute Selected Tests - Runs the tests selected in Choose Tests.

Choose Tests - Contains all the tests that can be selected for the Apple IIe.

Options - Contains various selections that allow you to control how the tests are run.

Special - Contains various options for keeping track of errors generated, for saving a test sequence, and for loading a test sequence from diskette.

Exit & Run Workstation Card Diagnostic - Terminates the Apple IIe diagnostic and starts the Apple II Workstation Card diagnostic.

Quit - Stops all testing and displays a message to reboot the system.

Choose Tests

The following list describes the items in the **Choose Tests** folder:

ROM/CPU Test - Checks the ROM and CPU.

System Interrupts Test - Checks that the interrupts are functioning correctly.

MMU/IOU Test - Checks the Memory Management Unit and the Input/Output Unit.

RAM Tests Folder

RAM Tests - This folder contains the following:

- Main Logic Board RAM Test - Checks the 64K RAM on the logic board.
- Extended 64K/80-Column Card RAM Test - Checks the RAM on the Apple IIe Extended 80-Column Card (if installed).
- Apple IIe Memory Expansion Card Test - Checks the RAM on the Memory Expansion Card. The card can be installed in any slot except 3. This test will not run unless selected. Refer to Section 6, Apple IIe Memory Expansion Card.

Disk Drive Tests Folder

Disk Drive Tests - This folder contains the following:

- Disk Card Test - Checks the drive circuitry on the interface cards for all 3.5- and 5.25-inch drives that are attached to the system. The diskette in each drive to be tested must be formatted with ProDOS.

Sound Tests Folder

Sound Tests - This folder contains the following:

- Speaker Tone Test - Checks the speaker by playing a sequence of beeps.

**Video
Pattern Folder**

Video Pattern Tests - This folder contains the following:

- Color Bar Test - Displays vertical color bars with the name of each color below.
- Character Generator Test - Displays the character set available.

Note: When running the Character Generator Test and using a ColorMonitor Iie or Composite Monitor Iie, the video display shifts left and right and toggles between color and monochrome. (This is the normal result of the method used to display the Character Set Test.)

To make the display easier to view, depress the White-Only switch during the Character Generator Test, and release the switch during all other tests.

- 80/40 Column Text Test - Displays a few lines of 80-column characters, then a few lines of 40-column characters.
- Low-Resolution Graphics Test - Displays both pages (one and two) of the low-resolution graphics mode with bars at the top of the screen.
- High-Resolution Graphics Test - Displays a grid of 9 vertical lines intersected by 8 horizontal lines.
- Double High-Resolution Graphics Test - Displays a grid of 18 vertical lines intersected by 8 horizontal lines.

**Keyboard/Mouse
Folder**

Keyboard/Mouse Tests - This folder contains the following:

- Standard Iie Keyboard Test - Displays a keyboard layout for the Apple Iie keyboard. The instructions are given at the bottom of the screen.
- Language - Displays a list of languages available for the keyboard tests. The default setting is U.S.A. English.

- Numeric Keypad Iie Test - Displays a numeric keyboard layout. The instructions are given at the bottom of the screen.
- Joystick/Paddle Test - Displays a pointer that can be moved around the screen and a box that indicates whether the joystick/paddle buttons are pressed or not. If testing paddles, verify that both reach the full range possible (0-FF).

Options

When the **Options** folder is open, the following list of selections appears on the screen.

Loop Tests Until ESC is Pressed Continue On Error Until ESC

If an option is selected, a check mark appears beside the item. To deselect an option, just select the same option again.

Special

The following selections appear when the **Special** folder is opened.

- Display Error Log - Displays the names of the tests that have failed since the last clearing of the error log (up to 255 names).
- Clear Error Log - Erases the log from RAM.
- Clear Testing Status Line - Clears the iterations and failure counts displayed.
- Display Current System Status - Indicates the type of system, the ROM version, the amount of memory available (number of banks) and the memory card status.
- Load Selected Test Sequence from Disk - Loads a previously saved test sequence. The sequence can then be executed.
- Save Selected Test Sequence to Disk - Saves a test sequence you have selected to the test diskette.

When any of the above items is selected and <Return> is pressed, the action is performed.

Running the Diagnostics

The diagnostic can be configured in various ways. All the tests can be run in their automatic sequence, or selected tests can be looped or run in an order you specify.

The diagnostic also has the ability to execute a test selection sequence that has been saved to the test diskette. Saved test sequences make it easier to test an Apple IIe that has an extended keyboard or other specially configured systems.

For information on the Apple II Memory Expansion Card refer to **Section 6, Apple IIe Memory Expansion Card**.

Standard Test

1. Install Extended 80-Column Card in the auxiliary slot.
2. Insert the Apple IIe Diagnostic Diskette and power on the system.
3. Type the letter a or use the arrows to select **Execute All Diagnostic Tests**, and press <Return>.

To continue after certain tests (for instance, Speaker, Video Patterns), press <Spacebar>.

If an error is encountered, the testing will stop and an alert box will appear specifying which test failed.

4. On completion, the message **Testing finished** will be displayed in the alert box.

Customized Test

1. Install the Extended 80-Column Card in the auxiliary slot. Install the Apple II Memory Expansion Card in any slot except 3.
2. Insert the Apple II Diagnostic Diskette and power on the system.
3. Type the letter c or use the arrows to select **Choose Tests**, and press <Return>.
4. From this menu, select the first three tests (if desired) and press <Return> to select them. Select the other test folders and press <Return> to display them. Select the tests you wish to run from each folder and press <Return> to select them.

If you wish to deselect a test, use the letters or arrows to select the test and press the <Delete> key.

5. To save your customized test sequence, return to the main menu, and select **Special**. Select **Save Selected Test Sequence to Disk** and press <Return>.

You now have the selected test sequence saved to diskette. The sequence may be loaded using **Load Selected Test Sequence from Disk** at a later date when it is needed.

6. On completion, return to the main menu, select **Execute Selected Tests**, and press <Return>.

To continue after certain tests (for instance, speaker, video patterns), press <Spacebar>.

If an error is encountered, the testing will stop and an alert box will appear specifying which test failed.

7. On completion, the message **Testing finished** will be displayed in the alert box.

Continuous Test

A continuous (looping) test is possible with all tests. Select the tests you wish to loop by following the instructions under "Customized Test" (see above). Follow the steps below to run a continuous test.

1. After you have chosen the tests you want to run, return to the main menu, select **Options**, and press <Return>.
2. From the menu, select **Loop Tests Until ESC is Pressed** and press <Return>.

A check mark should appear, indicating what has been selected.

3. Select **Continue On Error Until ESC** if you want to continue looping, regardless of the error, until <Escape> is pressed.

If you do not select this option, the testing will halt when an error is encountered.

Errors will be logged to RAM.

4. Return to the main menu, select **Execute Selected Tests**, and press <Return>.

The tests will run (depending on your selection in step 3) continuously until an error occurs or <Escape> is pressed. If <Escape> is pressed, looping is canceled.

If you press <Escape> to stop the testing, you can then check for errors by selecting **Special** and pressing <Return>. Then select **Display Error Log**.

5. If you are going to run the continuous test again, be sure to clear the error log and the status line and to reselect **Loop on Error Until ESC is Pressed** before returning to the main menu.

Test Failures

When a test fails, either a message will appear giving the name of the test that has failed, or the test will be listed in the error log. The following is a list of the tests along with the recommended remedial actions.

Tests

Remedial Action

- *ROM/CPU* – Exchange logic board.
- *System Speed/Interrupts* – Exchange logic board.
- *MMU/IOU* – Exchange logic board.
- *Main Logic Board RAM* – Exchange logic board.
- *Extended 80-Column Card*
 1. Exchange card.
 2. Exchange logic board.
- *Disk Port*
 1. Exchange drive.
 2. Exchange interface.
 3. Exchange logic board.
- *Speaker*
 1. Exchange speaker.
 2. Exchange logic board.
- *All Video* – Exchange logic board.
- *Ile Keyboard or Ile Extended Keyboard*
 1. Exchange cable.
 2. Exchange keyboard.
 3. Exchange logic board.
- *Numeric Keypad*
 1. Exchange numeric keypad.
 2. Exchange cable.
 3. Exchange logic board.

Tests

Remedial Action

- *Joystick/Paddle*
 1. Exchange joystick or paddles.
 2. Exchange logic board.

- *Apple II Memory Expansion Card*
 - Refer to Section 6, Apple II Memory Expansion Card, for more information.

Apple IIe

Section 3 – Troubleshooting

□ CONTENTS

3.2	Introduction
3.2	General Information
3.2	Before You Start
3.2	How to Use the Symptom Charts
3.3	Things to Remember
3.3	Logical Troubleshooting
3.4	Modules and Functions
3.6	Apple IIe Symptom Chart

□ INTRODUCTION

General Information

Use this troubleshooting section if the diagnostic is unable to detect a module failure or if the diagnostic diskette cannot be booted. After you repair the system, run the diagnostic test to verify system operation.

Before You Start

Read the section entitled "Things to Remember" before you begin troubleshooting. There are several things you should know about the Apple IIe to troubleshoot the system effectively.

How to Use the Symptom Chart

Use the left column to locate the symptom that best describes the problem of the defective system. For each symptom, perform the corrective action(s) in the order listed. If a corrective action does not fix the problem, proceed to the next step.

If a board is replaced but does not fix the problem, the original board should be reinstalled before you perform the next step.

□ THINGS TO REMEMBER

1. Electrostatic Discharge (ESD) can cause severe damage to sensitive microcircuits. To prevent ESD damage to the Apple IIe components, follow the precautions outlined for ESD prevention under the tab *You Oughta Know*.
2. Be sure the power is off before installing or removing any modules or components, or before connecting or disconnecting any peripheral devices.
3. After powering on the Apple IIe, there is sometimes a 20-to-30-second wait. During this time, "garbage" sometimes appears on the screen. To eliminate this problem, hold down the <Open-Apple> key when turning the system on.

□ LOGICAL TROUBLESHOOTING

Troubleshooting can be approached in many different ways. Apple recommends two methods in particular:

- Logical troubleshooting
- Module swapping in a particular order for a particular symptom

Most troubleshooting charts in the *Apple Service Technical Procedures* are based upon the module-swapping method, but you can often save repair time by using logical troubleshooting before you start swapping.

Logical troubleshooting involves knowing the function of each module in the machine, and using that information to narrow your search for the problem. This section will give you the information necessary to perform logical troubleshooting of the Apple IIe. The information here includes a description of each module in the IIe and the various functions it performs. (For definitions of basic terms, refer to Simplified Overview of a Microcomputer System in *You Oughta Know*.)

Modules and Functions

Logic Board

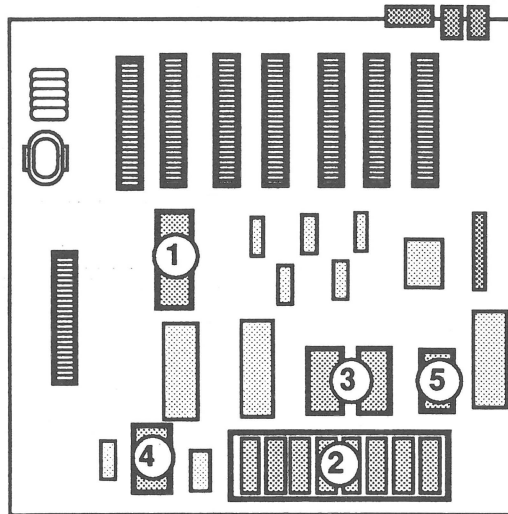

The logic board is the heart of the system. It contains the components described below. A number after an IC in the descriptions below corresponds to a number in the figure above (indicating the location of the component on the Apple IIe logic board). The ICs that have a number are exchangeable.

- The **CPU (1)**, a 6502 microprocessor, gets instructions from memory, translates them, and carries them out. It communicates with all components on the logic board.

Note: The IIe is available in an enhanced version. Refer to the *Module Identification Manual* for specific differences between the enhanced and unenhanced Apple IIe logic boards.

- The **Oscillator** (timing device) provides the master clock pulse for all the ICs on the board.
- The **RAM (2)** storage capability (on the logic board) is 64K. Additional RAM can be added by installing various add-on memory cards.
- The two **ROMs (3)**, at coordinates CD and EF, contain the AppleSoft editor and interpreter, the monitor, the 80-column display firmware, and the diagnostic self-test routines.

- The **character generator ROM (4)** changes the input code into the proper bit patterns for use by the external monitor.
- The **keyboard ROM (5)** converts the information into the proper code for the computer to use.
- The seven mail slots are used for plug-in cards, which are necessary to interface with external peripheral devices. For example, any disk drive or printer must be connected to the Iie via an interface card inserted into one of these slots.
- There is one additional slot, the auxiliary slot, which is considered slot 3. This slot is reserved for the 80-column card, RGB card, or a similar card (the card's manufacturer will specify whether the card requires installation in the auxiliary slot).

Power Supply

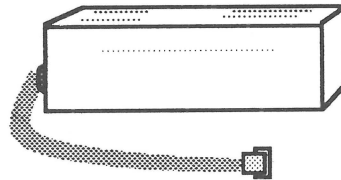

The power supply operates on standard line voltage and outputs various DC voltages, which are used by the logic board and by some peripheral devices (for example, Disk II and UniDisk).

Keyboard

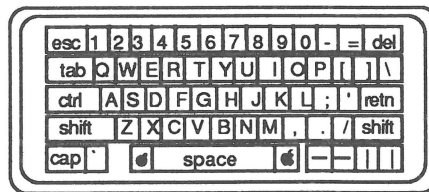

The keyboard information is sent via a cable to the logic board in the form of X and Y coordinates. The coordinates are converted by the keyboard encoder and keyboard ROM into a form that the logic board can use.

□ APPLE IIe SYMPTOM CHART

Video Problems

Solutions

- *No video*
 1. Exchange video cable.
 2. Exchange RAM.
 3. Exchange ROM at coordinates CD and EF.
 4. Exchange logic board.

- *Display is fuzzy on a known-good monitor*
 1. Exchange video cable.
 2. Exchange RAM.
 3. Exchange ROMs at coordinates CD and EF.
 4. Exchange logic board.

- *Garbage displayed on known-good monitor*
 1. Exchange RAM.
 2. Exchange ROMs at coordinates CD and EF.
 3. Exchange logic board.

Peripheral Problems

Solutions

- *Cassette saving problem*
 - Exchange logic board.

- *Cassette loading problem*
 - Exchange logic board.

- *Keys fail to remove appropriate character from keyboard test on Apple II diagnostic*
 - 1. Exchange keyboard cable.
 - 2. Exchange keyboard.
 - 3. Exchange keyboard ROM.
 - 4. Exchange logic board.

- *System locks up intermittently with Extended 80-Column Card installed*
 - 1. Exchange MMU.
 - 2. Exchange Extended 80-Column Card.
 - 3. Exchange logic board.

- *Display problem with Extended 80-Column Card installed*
 - 1. Exchange IC 74LS245 on the Extended 80-Column Card.
 - 2. Exchange Extended 80-Column Card.
 - 3. Exchange logic board.

- *The special function keys on the numeric keypad do not work properly*
 - If the Apple IIe contains a "revision C" character generator ROM at location E-12 on the logic board, exchange the ROM with any other version from service stock. **Do not replace the entire Apple IIe logic board.**

- *System does not auto boot with UniDisk 3.5 or Profile*
 - Only the enhanced Apple IIe auto boots with the UniDisk or Profile. To boot with these drives, type **PR#n** (where *n* represents the most likely slot number of the interface card) at the AppleSoft Basic command prompt.

Miscellaneous Problems

Solutions

- *Programs run erratically, often crash*
 1. Exchange RAM.
 2. Exchange ROMs at coordinates CD and EF.
 3. Exchange logic board.
 4. Exchange disk drive.

- *No beep and no message is displayed; monitor has random characters on screen when the Apple is turned on; drive does not come on*
 1. Exchange ROM at coordinates EF.
 2. Exchange RAM.
 3. Exchange power supply.
 4. Exchange logic board.

- *AppleSoft or Integer BASIC errors*
 1. Exchange ROM at coordinates CD.
 2. Exchange RAM.
 3. Exchange logic board.

- *No power light; no video*
 1. Exchange AC power cord.
 2. Exchange power supply.
 3. Exchange logic board.

- *No audio*
 1. Exchange speaker.
 2. Exchange logic board.

- *Diagnostic self-test runs at power on*
 1. Exchange keyboard cable.
 2. Exchange keyboard.
 3. Exchange logic board.

- *After exchanging logic board, system locks up and/or hisses*
 - Check speaker (wire may be pierced).

Apple IIe Technical Procedures

Section 4

Additional Procedures

Contents:

Apple IIe Enhancement Kit Upgrade.....4.3
Single-Wire Shift-Key Modification.....4.4

U.S.
VERSION

FIGURE 1

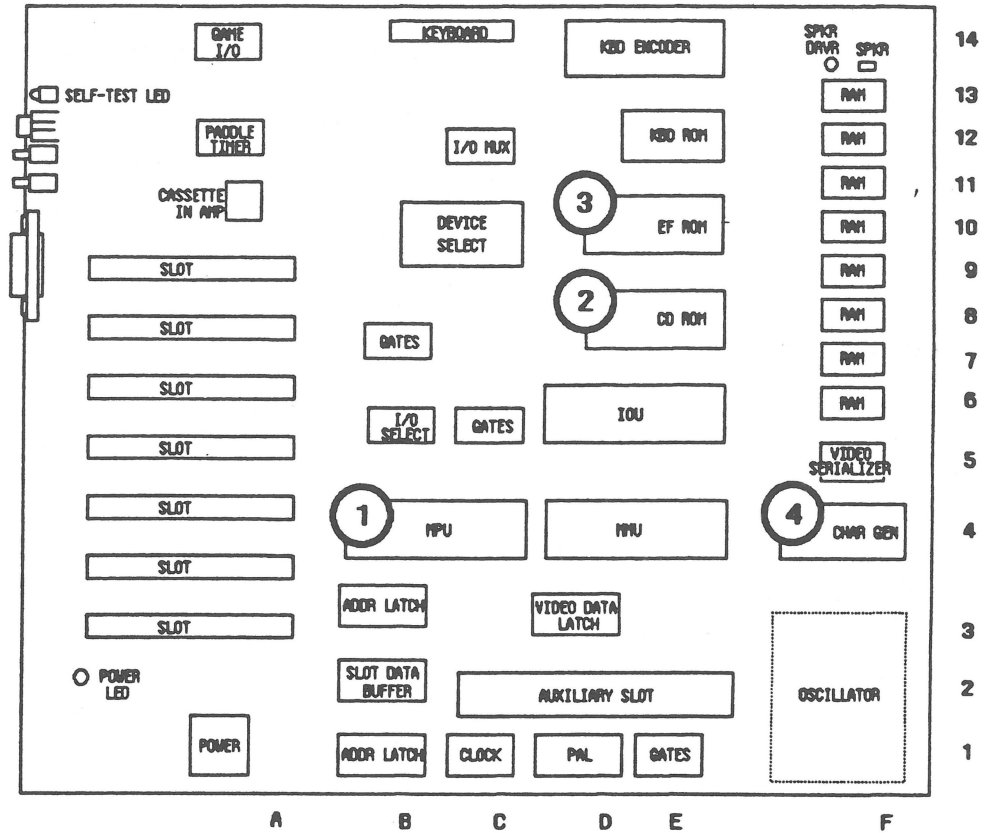

EUROPEAN
VERSION

FIGURE 2

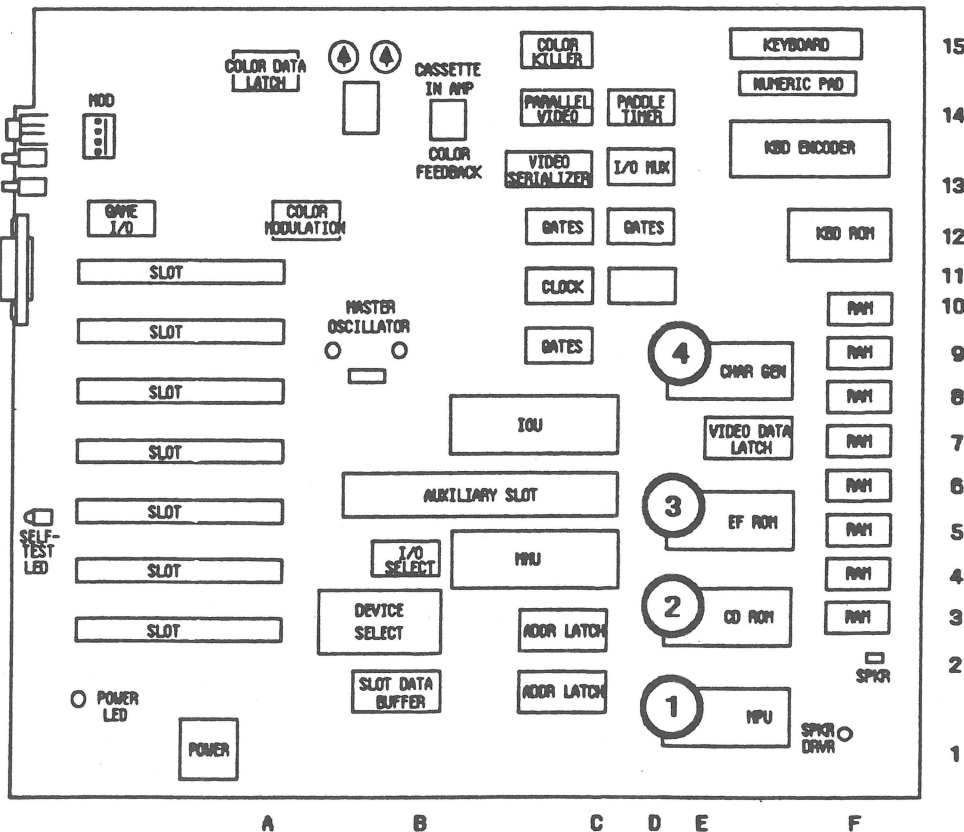

APPLE IIe ENHANCEMENT KIT UPGRADE

The Apple IIe Enhancement Kit makes an Apple IIe compatible with the advanced features available on the IIc. It allows the IIe to support interrupts for applications and networking. With the kit, the IIe also gains faster processing time and the ability to use the MouseText character display features.

To upgrade your IIe you will need to replace the following four ICs on the logic board:

- 1) The 6502 Microprocessor (P/N 370-6502) is replaced by the 65C02 Microprocessor (P/N 338-6503)
- 2) The CD Monitor ROM (P/N 342-0135) is replaced by the CD Monitor ROM (P/N 341-0304)
- 3) The EF Monitor ROM (P/N 342-0134) is replaced by the EF Monitor ROM (P/N 341-0303)
- 4) The Video (Character Generator) ROM (P/N 342-0133) is replaced by the Character Generator ROM (P/N 342-0265)

See Figure 1, page 4.2 for U.S. IIe logic board layout and location of the ICs. See Figure 2, page 4.2 for European IIe logic board layout and location of the ICs.

The numbers above correspond with the numbers on the appropriate layout.

Installation Procedures

WARNING: The four ICs you will be installing are extremely susceptible to static discharge. Before handling these ICs be sure to touch the metal power supply case to discharge any electricity that may have built up on your body or clothing.

1. Power off the IIe system.
2. Remove the cover and all interface cards.
3. **Touch the power supply.**
4. Referring to Figure 1 on page 4.2 (for the U.S. logic board), or Figure 2 on page 4.2 (for the European logic board) locate the four chips to be replaced.

5. Remove the chips using an IC extractor. For the 6502, use a small, narrow, flatblade screwdriver to gently pry up each end of the IC a little at a time. Be careful that you do not scratch the logic board traces when using the screwdriver.
6. **Touch the power supply again** to be sure that you are completely discharged.
7. Identify the new chips and remove them from the piece of antistatic foam. Install each chip at the appropriate location.

IMPORTANT: There is a notch at one end of each chip. This notch should face the keyboard on installation.

8. Place the old chips on the antistatic foam.
9. Replace the interface cards you removed, replace the cover, and run a IIC program to verify that the upgrade works correctly.

SINGLE-WIRE SHIFT-KEY MODIFICATION

The single-wire shift-key modification, which wasn't present on revisions A and B of the Apple IIe logic board, is now hard-wired. The change was made to allow mouse-based applications to detect a "shifted click" and to allow software that utilized the old single-wire shift-key method to work without modification to the logic board.

Important: On X6-jumpered logic boards, never simultaneously depress the shift key and switch 2 of the gameport. This combination will result in a short of +5V to ground and cause a shutdown of the power supply.

To separate the shift-key and switch-2 functions to prevent shorting +5V to ground, perform the following procedure.

Materials Required

X-acto knife
Digital multimeter

1. Locate the jumper pads marked X6 on the logic board (located to the left of the keyboard connector). Using the X-acto knife, cut vertically between the two jumper pads.
2. Use the ohmmeter to verify that the two jumper pads are not touching.

Apple IIe

Illustrated Parts List

☐ CONTENTS

- IPL.3 Finished Goods Assembly (Figure 1)
- IPL.5 Platinum Case and Extended Keyboard (Figure 2)
- IPL.7 Logic Board (Figure 3)
- IPL.7 Power Supply Switch (Figure 4)
- IPL.9 Power Supply (Figure 5)
- IPL.9 Spacebar Stabilizer Assembly (Figure 6)

The figures and lists in this section include all piece parts that can be purchased separately from Apple for the Apple IIe, along with their part numbers. These are the only parts available from Apple. Refer to your *Apple Service Programs* manual for prices.

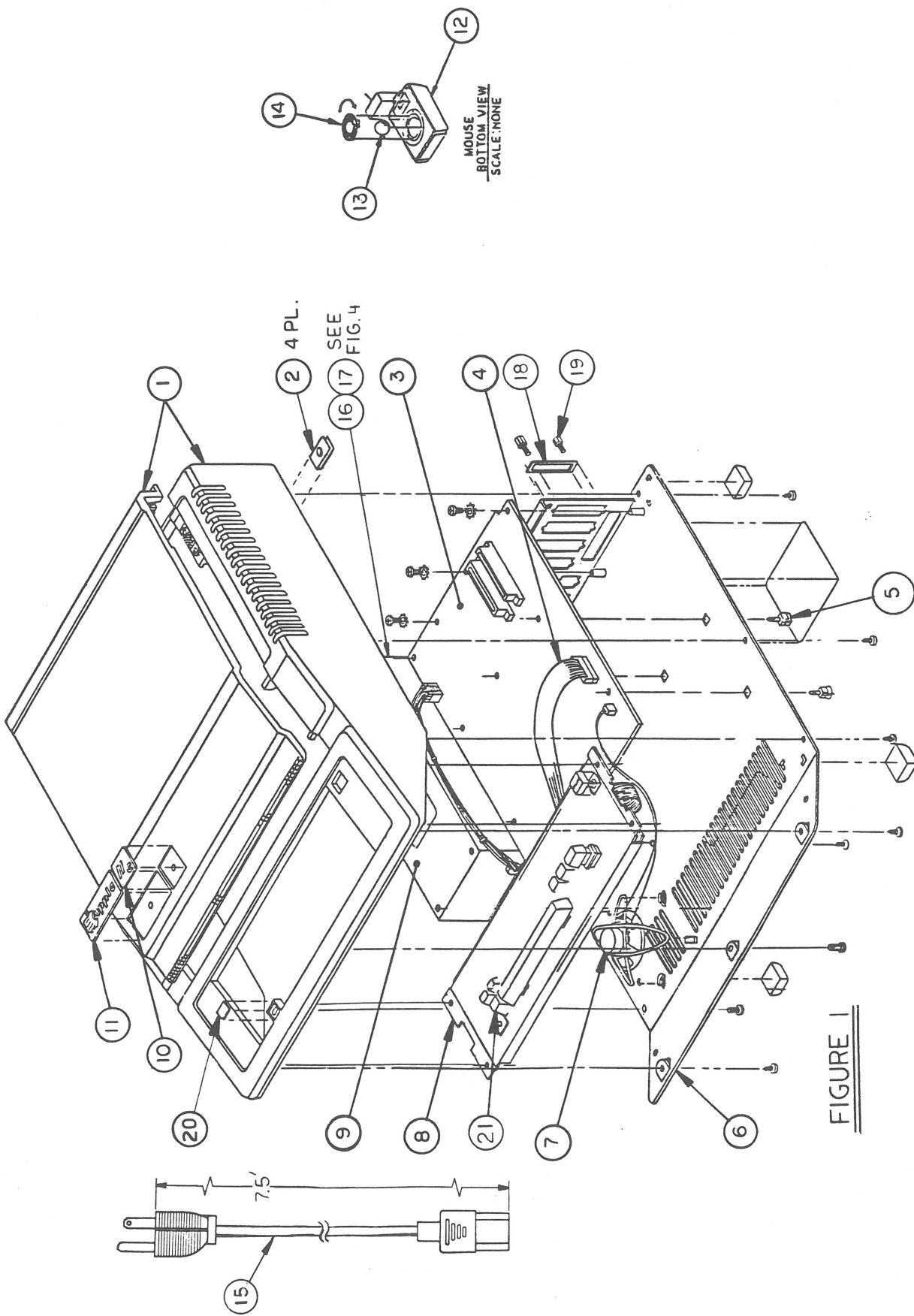

FIGURE 1

□ **FINISHED GOODS ASSEMBLY (Figure 1)**

<u>Item</u>	<u>Part No.</u>	<u>Description</u>
1	076-0127	Case & Lid, Beige
2	835-0174	Nut, U-Type
3	661-91084	Logic Board
4	590-0108	Keyboard Cable
5	860-0044	Standoff, Platinum
6	810-0585	Base Pan
7	600-0009	Speaker Assembly
8	661-91085	Alps Long-Stem Keyboard
	661-95139	SMK Short-Stem Keyboard
	661-95233	SMK Long-Stem Keyboard
9	661-0455	Apple II, Iie Power Supply
10	825-0359	Iie Nameplate
11	825-0054	Apple Nameplate
12	661-0259	Apple II Mouse Assembly
	661-0400	AppleMouse, Platinum
13	699-8001	Rubber-Coated Mouseball
14	815-0409	Mouseball Retainer
15	590-0380	Power Cable, Smoke
16	705-0023	Switch, Power Supply, Rocker, Two-Pole
17	705-0065	Switch, Power Supply, Rocker, Three-Pole
18	805-0110	Plate, Nut, 25-Pin
19	835-0006	Screw, Hexagon Nut Plate
20	825-0352	Power-on Label
21	658-7045	Alps Keycap Set, Beige with Black

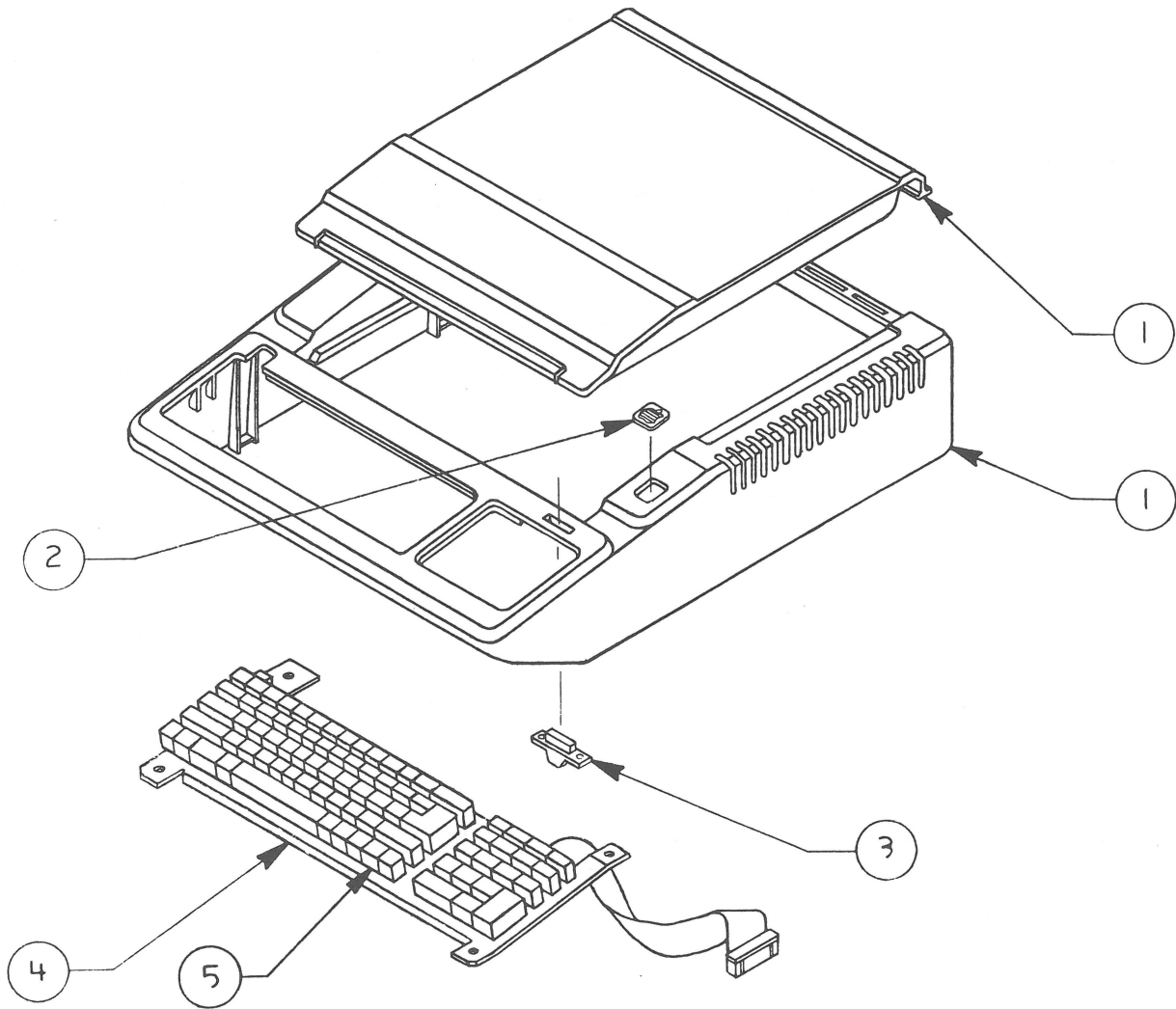

FIGURE 2

□ PLATINUM CASE AND EXTENDED KEYBOARD (Figure 2)

<u>Item</u>	<u>Part No.</u>	<u>Description</u>
1	607-5015	Case & Lid, Platinum
2	825-1340	Logo Label, Platinum
3	815-0586	Power-on Light Pipe
4	661-0357	Apple IIe Extended Keyboard, Platinum
5	658-7014	Apple IIe Keycap Set, Platinum

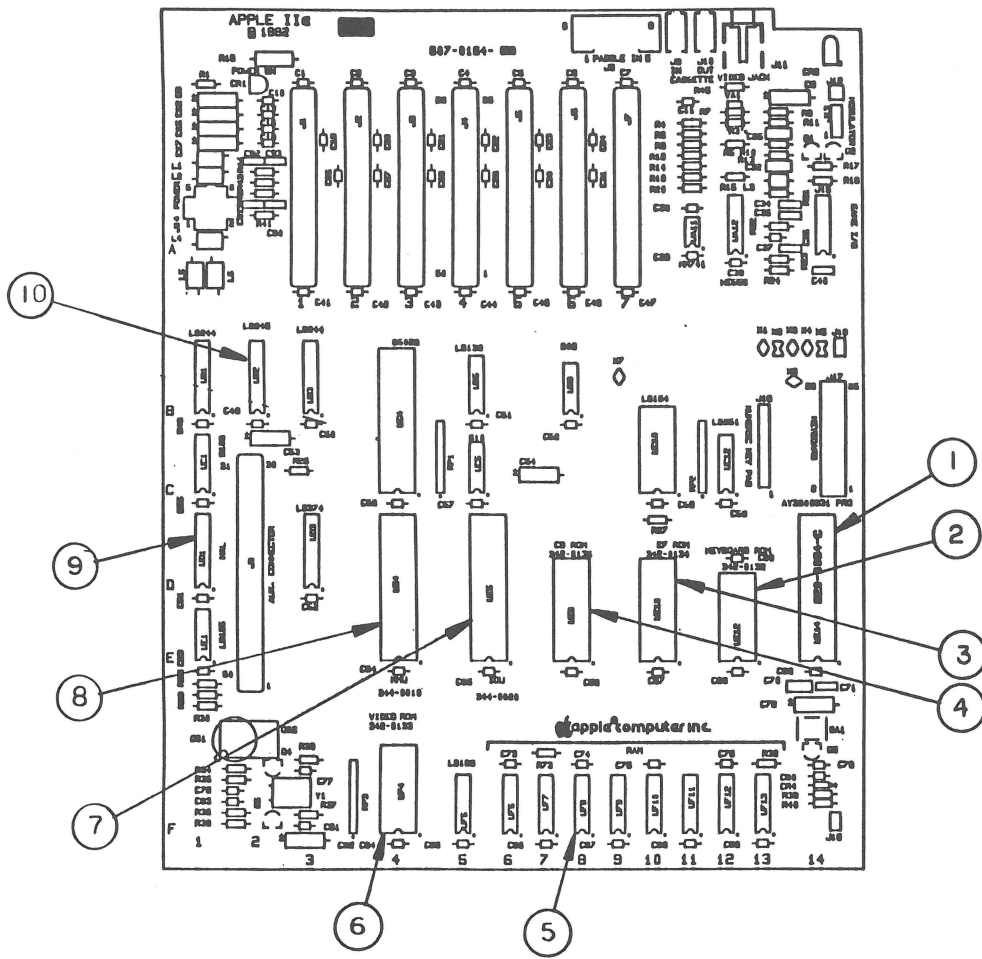

FIGURE 3

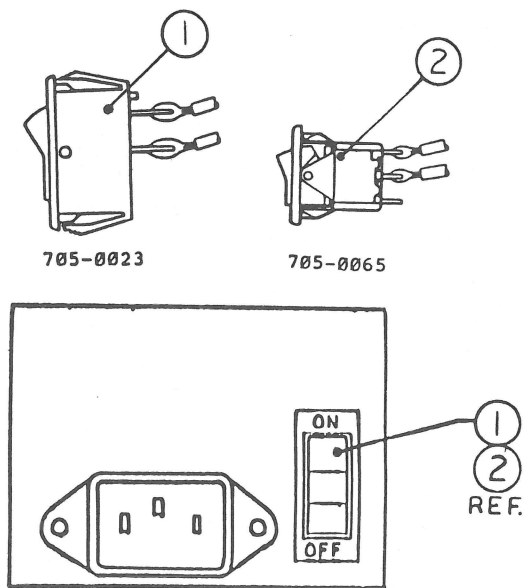

FIGURE 4

□ LOGIC BOARD (Figure 3)

<u>Item</u>	<u>Part No.</u>	<u>Description</u>
1	332-9600	IC, Keyboard Encoder
2	342-0132	IC, ROM 16K Keyboard
3	342-0134	IC, ROM 'EF' Firmware
	342-0303	IC, ROM 'EF' Enhanced Firmware
4	342-0135	IC, ROM 'CD' Firmware
	342-0304	IC, ROM 'CD' Enhanced Firmware
5	334-0003	IC, RAM 64K 200 NS w/Logo
6	342-0133	IC, ROM 32K Charc Gen
7	344-0020	IC, IOU
8	344-0010	IC, MMU
9	342-0170	IC, PAL 16R8
10	306-0245	IC, 74LS245

□ POWER SUPPLY SWITCH (Figure 4)

<u>Item</u>	<u>Part No.</u>	<u>Description</u>
1	705-0023	Switch, Power Supply, Rocker, Two-Pole
2	705-0065	Switch, Power Supply, Rocker, Three-Pole

Note: The items listed for the Power Supply Switch are also referenced in Figure 1 as well as Figure 4.

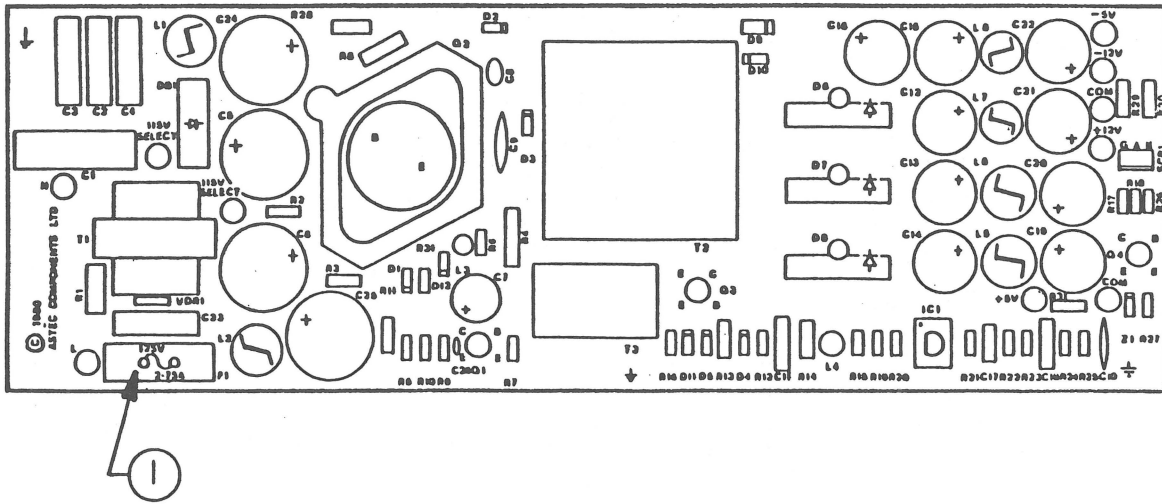

FIGURE 5

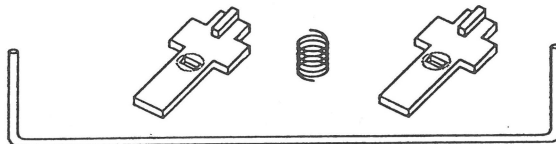

FIGURE 6

□ POWER SUPPLY (Figure 5)

<u>Item</u>	<u>Part No.</u>	<u>Description</u>
1	740-0001	Fuse, Power Supply, 1 Amp, 250V

□ SPACEBAR STABILIZER ASSEMBLY (Figure 6)

<u>Item</u>	<u>Part No.</u>	<u>Description</u>
-	076-8343	Spacebar Stabilizer Assembly (Consists of Stabilizer Bar, two Mounting Tabs, and four Springs)

The following keyswitches are illustrated in the Apple IIe product section, Appendix A, of your Technical Procedures Binder.

705-0015	Alps Short-Stem Keyswitch
705-0070	Alps Long-Stem Keyswitch
705-0075	SMK Short-Stem Keyswitch
705-0077	Alps Alpha Lock Keyswitch
705-0079	SMK Short-Stem Keyswitch
705-0080	SMK Caps Lock, Short Stem
705-0081	SMK Long-Stem Keyswitch
705-0082	SMK Caps Lock, Long Stem
705-0084	SMK Low-Friction, Long Stem
705-0085	SMK Low-Friction, Short Stem
815-0772	Straight Adapter
705-0044	Mitsumi Locking Keyswitch
705-0104	Mitsumi Keyswitch

Apple IIe Technical Procedures

Section 6

Apple II Memory Expansion Card

Contents:

Introduction.....6.3
Things to Remember.....6.3
Diagnostics and Troubleshooting.....6.4

MEMORY CONFIGURATION CHART

256K RAM CHIP

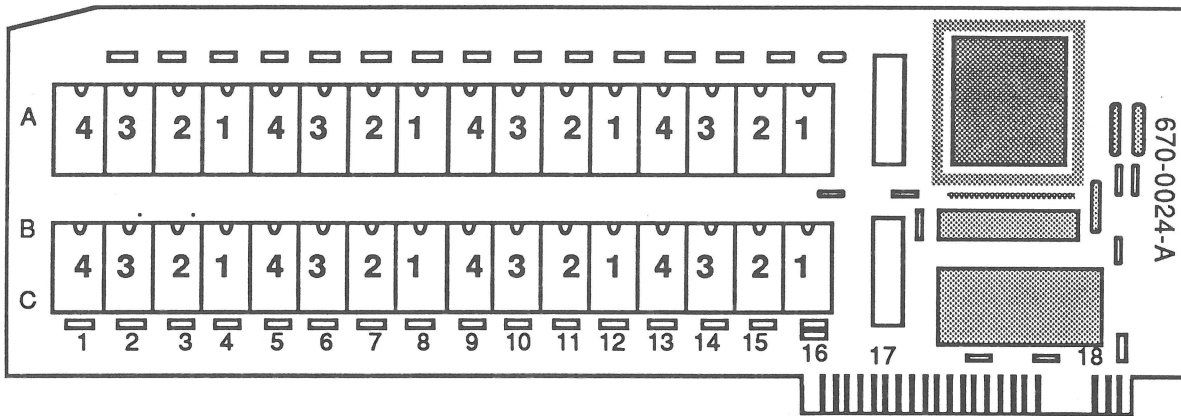
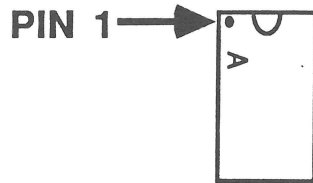

CARD SIZE	LOCATIONS OF 256K RAM CHIPS
256K	1
512K	1, 2
768K	1, 2, 3
1MB	1, 2, 3, 4

INTRODUCTION

The Apple® II Memory Expansion Card can be used with any of the expandable personal computers in the Apple II family. This card allows you to use an additional 256K, 512K, 768K or 1 Megabyte of temporary storage when using the ProDOS® Operating System.

THINGS TO REMEMBER

1. The Memory Expansion Card has ICs which are **HIGHLY SUSCEPTIBLE TO DAMAGE FROM ELECTROSTATIC DISCHARGE**. Ground yourself by touching the power supply case before picking up the Memory Expansion Card or installing it into any system. To further prevent any damage from electrostatic discharge, place the board in an anti-static bag before carrying it anywhere.
2. The Memory Expansion Card exchange modules are shipped **WITHOUT RAM**. All RAM ICs are considered a replaceable part. The 256K RAM is **SUSCEPTIBLE TO DAMAGE FROM ELECTROSTATIC DISCHARGE**. Touch the power supply case before handling or installing the RAM chips. **Remember to remove the RAM from the board you are sending to Apple. Bad RAM should not be sent in on the card.**
3. **The RAM has to be inserted in the correct sockets for the desired configuration.** Remember to place the dot or indentation on the chip in the correct direction for pin 1. Refer to the Memory Configuration Chart on the opposite page for the location and orientation of RAM.
4. Only Apple RAM should be used as replacement parts. (Apple RAM has the letter A near pin 1.)
5. The Memory Expansion Card works with the ProDOS Operating System. ProDOS automatically recognizes the card as a **RAMDISK**.
6. The Memory Expansion Card must be installed in slot 4, 5, or 6 to work with the Pascal Language System.
7. On the Apple IIe, the Memory Expansion Card can be installed in any slot except 3. On the Apple II Plus, the Memory Expansion Card can be installed in any slot except 0 (the Language Card must be installed there).
8. The Memory Expansion Card has no battery backup. The card is intended for temporary storage. Caution users to save their data often (every 15 to 20 minutes)!!

DIAGNOSTICS AND TROUBLESHOOTING

The Apple II Memory Expansion Card exchange module is shipped without socketed RAM. All socketed RAM must be removed before returning it to Apple.

Materials Required	Known-good Apple IIe 3.5-inch (or 5.25-inch) Disk Drive Known-good RAM Apple II Memory Expansion Card Apple II Diagnostic Diskette
---------------------------	--

Testing the RAM

1. Install the Apple II Memory Expansion Card into any slot except 3.
2. Start up the Apple II Diagnostic Diskette (refer to **Section 2, Diagnostics**). Select the Apple II Memory Expansion Card Test and run the test.
3. Two types of failures are possible on the Apple II Memory Expansion Card:
 - a) If a RAM chip fails, coordinates on the board are shown on the screen. The top row of RAM has the coordinates A1 through A16. The bottom row of RAM has the coordinates C1 through C16.
 - 1) Locate the RAM and replace it with a known-good RAM chip.
 - 2) Retest the card.
 - 3) Repeat steps 1) and 2) until the card passes.
 - b) If the problem cannot be corrected by replacing a RAM chip, the screen will tell you to exchange the entire card.
 - 1) Remove all the RAM from the customer's card.
 - 2) Test the module being used for exchange using eight known-good RAMs.
 - 3) Install the customer's RAM into the new module.
 - 4) Retest the card.
 - 5) Return to the beginning of this step until the card passes.

Apple IIe

Appendix A – Apple IIe Keyboard and Keyswitch Identification

□ CONTENTS

- A.3 Background Information
- A.3 Keyboard and Keyswitch Differences
- A.4 Identifying Keyboards and Keyswitches

□ BACKGROUND INFORMATION

Apple IIe keyboards use several different types of keyswitches. To replace a faulty keyswitch, you must use a new one of the same type.

This section contains a chart with drawings and part numbers of all IIe keyswitches, listed by keyboard type. Before you use the chart, read the following background information on keyboards and keyswitches.

Keyboard and Keyswitch Differences

There are five main types of Apple IIe keyboards: Alps long stem, Alps short stem, SMK long stem, SMK short stem, and Mitsumi. On each keyboard, most keys have the standard ("alphanumeric") keyswitches shown below. (Special keyswitches are used for Caps Lock, Reset, and some other function keys. Refer to Figure 3, later in this procedure, after you know which type of keyboard you have.)

"Short stem" keyswitches use adapters, small plastic pieces (usually white) that fit on the stem to make it longer. The keycap sits on the adapter.

"Long Stem" keyswitches (and Mitsumi keyswitches) do not have adapters—the keycap fits directly on the keyswitch.

Alps and **Mitsumi** keyswitches have do **not** have cylindrical stems. **SMK** keyswitches have **cylindrical** stems, as shown in Figure 1.

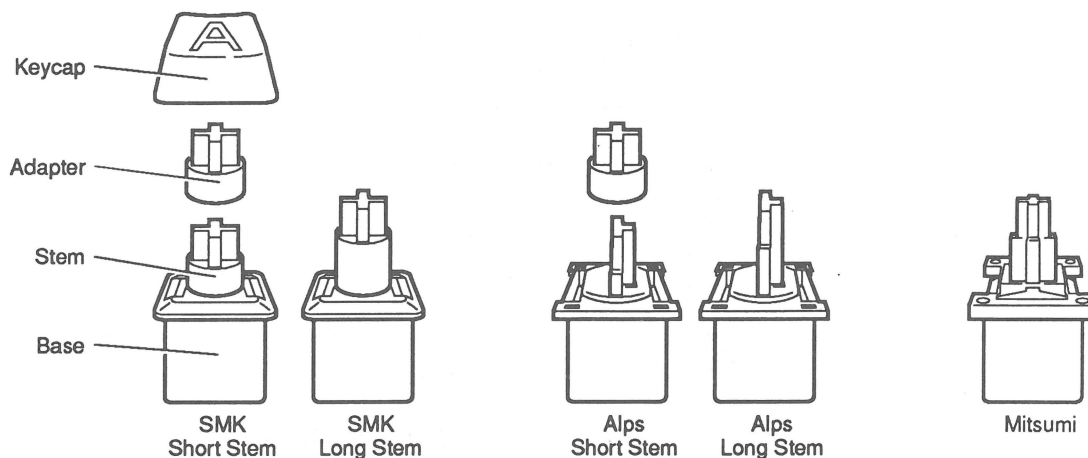

Figure 1 Keyswitch Stems

Identifying Keyboards and Keyswitches

1. Pry off the keycap with a small screwdriver so that you can see whether the keyswitch uses an adapter and whether the stem is cylindrical.
2. If the keyswitch has no adapter and no cylindrical stem, it could be an Alps long stem or a Mitsumi. To determine which it is, examine the Caps Lock keyswitch. If there is a spring around the stem, it is an Alps long stem; if not, it is a Mitsumi.
3. Use the table below to identify the general type of keyswitch (Alps, SMK, or Mitsumi; long stem or short stem). Then use Figure 3 (see next two pages) to identify the exact keyswitch needed.

Table 1

Keyswitch Type	SMK Short Stem	SMK Long Stem	Alps Short Stem	Alps Long Stem	Mitsumi
Stem shape (lower part of stem)	Cylindrical	Cylindrical	Not cylindrical	Not cylindrical	Not cylindrical
Keyswitch uses adapter?	Yes	No	Yes	No	No
Caps lock key has spring?	N/A	N/A	N/A	Yes	No

4. You can also identify a standard Apple IIe keyboard (without a numeric keypad) by finding the plate number on the black metal keyboard plate. After you remove the keyboard from the computer, locate this number on the top-left edge of the plate (see Figure 2). (The Mitsumi keyboard has no plate number.) Then find the plate number in the left column of Figure 3, and look in the right column to find the exact keyswitch.

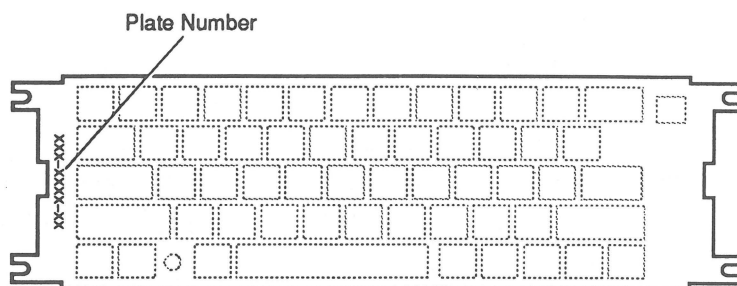

Figure 2 Plate Number

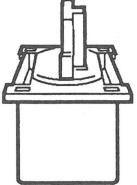

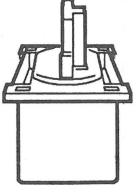
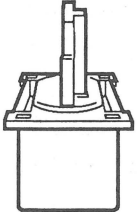

Plate Number on Keyboard	Keyswitches Used	
805-0195	 <p>815-0772 Adapter</p>  <p>705-0015 Alps Short Stem</p>	 <p>Spring (Included)</p>  <p>705-0077 Alps Short Stem with Alternate Action (Caps Lock Key)</p>
805-0182	 <p>705-0070 Alps Long Stem</p>	 <p>Spring (Included)</p>  <p>705-0077 Alps Short Stem with Alternate Action (Caps Lock Key)</p>
(None)	 <p>705-0104 Mitsumi Keyswitch</p>	 <p>705-0044 Mitsumi Locking Keyswitch</p>

Figure 3 Apple IIe Keyswitches

Plate Number on Keyboard	Keystitches Used		
805-0199	 <p>705-0079 SMK Short Stem (Reset Key)</p>	 <p>705-0081 SMK Long Stem</p>	 <p>705-0082 SMK Long Stem with Alternate Action (Caps Lock Key)</p>
805-0192	 <p>815-0772 Adapter</p> <p>705-0079 SMK Short Stem (Alphanumeric Keys; Reset Key without adapter)</p>	 <p>815-0772 Adapter</p> <p>705-0085 SMK Short Stem with Low Friction (Space bar and Shift Key; sometimes Tab, Ctrl, Delete, and Return Keys)</p>	 <p>705-0080 SMK Short Stem with Alternate Action (Caps Lock Key)</p>

Figure 3 Apple IIe Keystitches (continued)

Apple IIe Technical Procedures

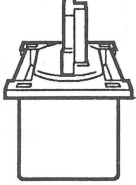
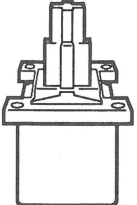
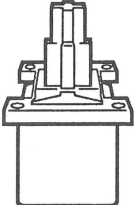
Appendix B

Apple II Plus and Apple IIe: Differences

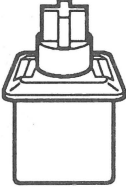
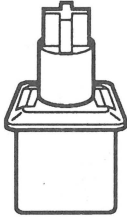
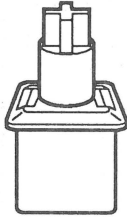
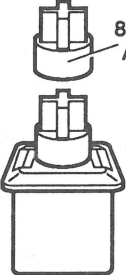
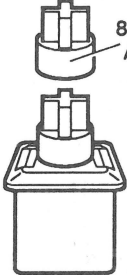
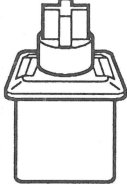
The question most often asked is, "What are the differences between the Apple II Plus and the Apple IIe?" When you look at the systems, several differences are apparent, such as the layout of the keyboard and the addition of keys for the Apple IIe. With these new keys additional functions can be performed.

You can see other differences when you remove the cover. First, many of the options for the Apple II Plus are standard on the Apple IIe, such as a built-in language card. The Apple IIe has only 31 chips, the language card is built-in, and there is an auxiliary slot for an 80 column card. Not visible is the fact that the Apple IIe runs self-diagnostics when the system is booted.

A table of the differences between the Apple II Plus and the Apple IIe is shown on the following page.

APPLE II PLUS AND APPLE IIe: DIFFERENCES

	Apple II Plus	Apple IIe
CPU	6502	6502A
Main Memory	48K expandable to 64K (110 ICs)	64K expandable to 128K (31 ICs)
Graphics Capabilities	Hi-Res capability	Double Hi-Res can be added
Keyboard	Upper case 51 keys No auto repeat	Upper/lower case 63 keys Auto repeat
Arrow keys	Use i,j,k,m	right, left, up, down
Screen display	40 characters/line	40 characters/line; can be extended to 80
Expansion	8 expansion slots (0 - 7)	8 expansion slots - 7 general purpose - auxiliary 80 column
Operating system	DOS	DOS 3.3, ProDOS®
Built-in Language (in ROM)	Applesoft BASIC	Applesoft BASIC
Languages Available	Auto-start Monitor (in ROM), Integer BASIC, Pascal, FORTRAN, C/S, COBOL, Pilot, Logo, many others	Same as Apple II Plus
Expansion Cards	Language card (16 byte expansion memory), Integer BASIC firmware, hobby prototyping cards, Memory Expansion card, and others	80 column text card, Extended 80 Column card, Memory Expansion card, and others
Interface Cards	Super Serial Interface Parallel Interface IEEE 488 Interface	Super Serial Interface Parallel Interface IEEE 488 Interface

Apple IIc

Table of Contents

Section 1 – Basics	1.2	Product Description
	1.2	Display
	1.2	CPU
	1.2	Memory
	1.2	Disk Drives
	1.3	Input/Output
	1.3	Keyboard
	1.3	Indicators
	1.4	Interface Ports
	1.6	Other Information
	1.6	Differences Between the Apple IIc's
	1.7	Theory of Operation
	1.7	Introduction
	1.9	Logic Board
	1.10	AC Power Pack
	1.10	Internal Power Supply
	1.11	Internal Disk Drive
1.11	Keyboard	
1.12	Electrostatic Discharge (ESD) Precautions	
Section 2 – Take-Apart	2.3	Electrostatic Discharge Precautions
	2.4	Top Cover
	2.6	Keyboard and Memory Expansion Card
	2.8	Disk Drive
	2.9	Analog Card
	2.12	Mechanical Assembly
	2.12	Bezel, Door, and Spring Assembly
	2.14	Internal Power Supply
	2.15	Speaker
	2.17	Logic Board
2.18	Volume Control	
2.19	Power Switch	

**Section 3 –
Preventive
Maintenance**

- 3.2 Introduction
- 3.2 Disk Drive Read/Write Head
- 3.3 Disk Drive Head Load Button

**Section 4 –
Diagnostics**

- 4.2 Introduction
- 4.3 Things to Remember
- 4.3 Before You Begin
- 4.3 Setting Up
- 4.4 While Testing
- 4.5 Built-In Diagnostic
- 4.5 Running the Diagnostic
- 4.5 Results
- 4.6 Apple IIc Diagnostic Diskette
- 4.6 Materials Required
- 4.6 Main Menu
- 4.7 Choose Tests
- 4.10 Options
- 4.10 Special
- 4.11 Running the Diagnostics
- 4.15 Test Failures

**Section 5 –
Troubleshooting**

- 5.2 Introduction
- 5.2 General Information
- 5.2 Before You Start
- 5.2 How to Use the Symptom Charts
- 5.3 Things To Remember
- 5.3 Symptom Chart
- 5.3 Video Problems
- 5.3 Display Problems
- 5.3 Peripheral Problems
- 5.4 Miscellaneous Problems
- 5.5 Special Problem Symptom Chart

**Section 6 –
Additional
Procedures**

- 6.2 Apple IIc - Model A2S4100
- 6.2 Memory Expansion Card Installation
- 6.6 Diagnostics and Troubleshooting
- 6.9 Logic Board Rubber Feet Installation
- 6.10 Apple IIc - Model A2S4000
- 6.10 UniDisk 3.5 Compatibility
- 6.10 Serial Port Upgrade
- 6.10 AC Power Pack Upgrade
- 6.11 Internal Power Supply Shield Retrofit
- 6.12 Upper Head Shield Plate Installation
- 6.16 Internal Power Supply Upgrade
- 6.17 Expandable Logic Board Installation

**Section 7 –
Adjustments**

- 7.2 DSPEED

**Illustrated –
Parts List**

- IPL.3 Finished Goods Assembly
- IPL.5 Memory Expansion Card

©Apple Computer, Inc., 1986, 1987. No portion of this document may be reproduced in any form without the written permission of Apple Computer, Inc.

Apple IIGS, Apple 5.25 Drive, UniDisk 3.5, AppleColor, and AppleMouse are trademarks of Apple Computer, Inc.

Apple IIc, ProDOS, Apple, and the Apple logo are registered trademarks of Apple Computer, Inc.

Apple IIc

Section 1 – Basics

□ CONTENTS

1.2	Product Description
1.2	Display
1.2	CPU
1.2	Memory
1.2	Disk Drives
1.3	Input/Output
1.3	Keyboard
1.3	Indicators
1.4	Interface Ports
1.6	Other Information
1.6	Differences Between the Apple IIc's
1.7	Theory of Operation
1.7	Introduction
1.9	Logic Board
1.10	AC Power Pack
1.10	Internal Power Supply
1.11	Internal Disk Drive
1.11	Keyboard
1.12	Electrostatic Discharge (ESD) Precautions

□ PRODUCT DESCRIPTION

The latest addition to the Apple® IIc family incorporates an expansion connector that supports the addition of a Memory Expansion Card. System memory can now be expanded to 1.15 megabytes.

Display

The video display has the following capabilities:

- 40-column x 24-line text mode
- 80-column x 24-line text mode
- Low-resolution graphics (40 x 48)
- High-resolution graphics (80 x 192)
- Double high-resolution graphics (560 x 192)
- 96 ASCII characters including upper and lower case, 32 graphics characters (Mousetext)
- NTSC compatible output

CPU

The central processing unit has the following attributes:

- 65C02 at 1.02 MHz
- 8-bit data bus
- 16-bit address bus

Memory

The IIc has the following memory capabilities:

- 128K RAM, expandable to 1.15 Megabytes with a Memory Expansion Card
- 32K ROM

Disk Drives

Mass storage is available in the following configurations:

- 5.25" built-in
- 5.25" or 3.5" external drive (optional)

Input/Output

A variety of built-in I/O ports and devices are included:

- Built-in speaker
- Connector for using headphones
- Joystick/Mouse port
- 2 RS-232 Serial ports
- Video expansion port

Keyboard

The keyboard has the following features:

- 63 keys
- 128-character ASCII set including 32 control characters
- Upper and lower case
- DVORAK or Sholes standard layout

Indicators

The following indicators are present:

- Power
- Disk activity

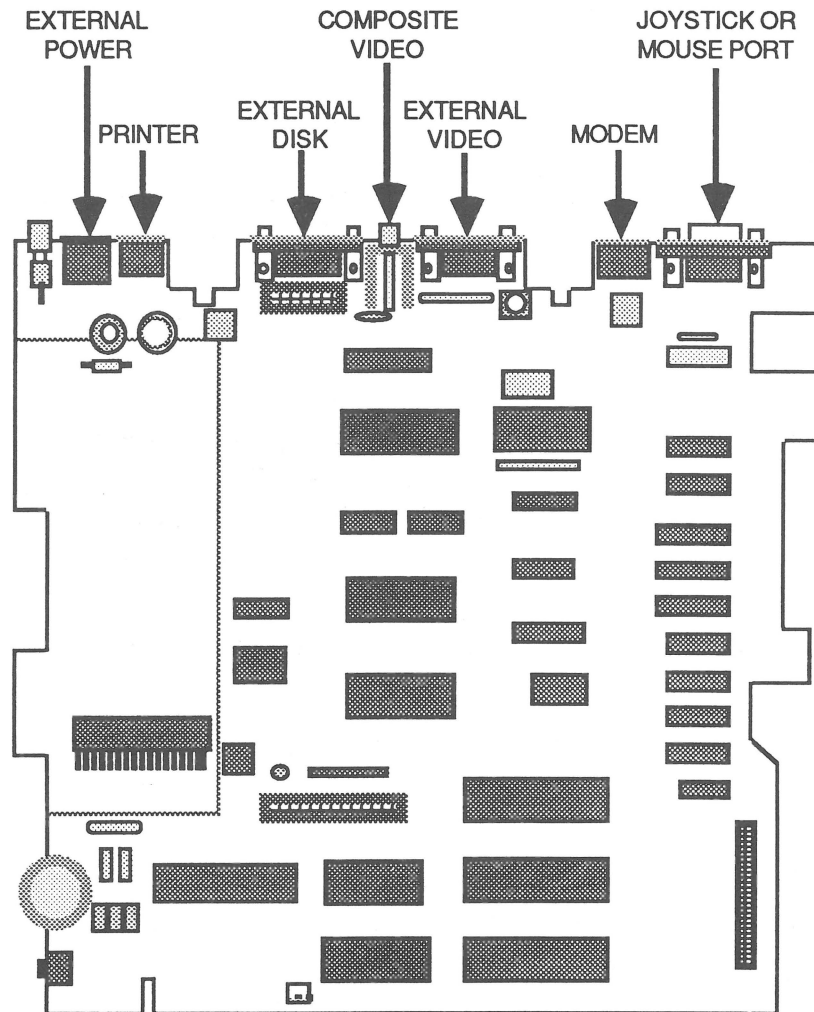

FIGURE 1

Interface Ports

The Apple IIc contains the following interface ports (Figure 1):

- **Joystick/Mouse**
- Support for Mouse IIc
- Support for Joystick IIc

- **Modem**
- RS-232 serial
- 50 to 19.2K baud
- 5, 6, 7, or 8 data bits
- 1 or 2 stop bits
- Odd, even, or no parity
- DIN-5 connector

- **External Video**
 - RF modulator support
 - Flat Panel Display
 - RGB output
- **Composite Video**
 - NTSC composite monochrome and color
- **External Disk**
 - Supports the Disk IIc®, Apple 5.25 Drive™, and UniDisk™ 3.5
- **Printer**
 - Identical to Modem Port (see above).
- **External Power Connector**
 - Connection to AC Power Pack

□ OTHER INFORMATION

Differences Between the Apple IIc's

This section describes the differences between the older Apple IIc (designated as model A2S4000) and the current IIc (designated as model A2S4100). The model number is found on the case bottom along with the serial number tag.

	A2S4000	A2S4100
Maximum Memory Configuration	128K	1.15 MB
Cosmetics	White case Beige highlights	White case Platinum highlights
Functional	Slot 4 - Mouse Port Slot 7 - Reserved	Slot 4 - Memory Expansion Card Slot 7 - Mouse Port

□ THEORY OF OPERATION

Introduction

Troubleshooting can be approached in many different ways. Apple recommends two methods in particular: logical troubleshooting and module swapping in a particular order for a particular symptom. Most troubleshooting charts in Apple Technical Procedures manuals are based upon the module-swapping method, but you can often save repair time by using logical troubleshooting before you start swapping.

Logical troubleshooting involves knowing the function of each module in the machine, and using that information to narrow down your search for the problem. This section will provide you with the information necessary to perform logical troubleshooting of the Apple IIc. The information here includes a description of each module in the IIc and the various functions it performs. (For definitions of basic terms, See "Simplified Overview of a Microcomputer System," under the tab *You Oughta Know*.)

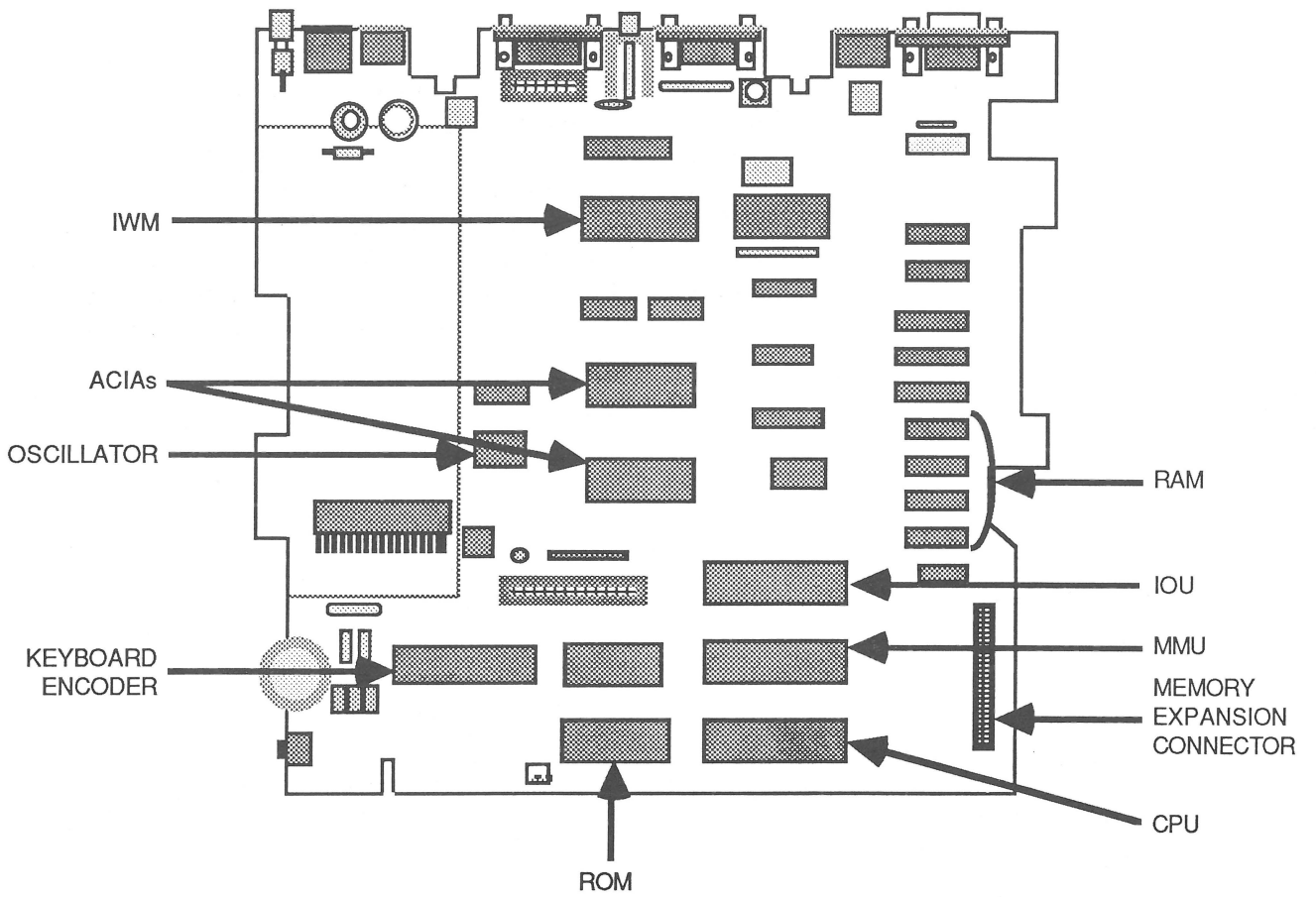

FIGURE 2

Logic Board

The Logic Board (Figure 2) is the heart of the system. It contains the components described below.

- The **CPU**, a 65C02 microprocessor, gets instructions from memory, translates them, and carries them out. It communicates with all components on the Logic Board.
- The **RAM** (read/write memory) is used to store, on a temporary basis, programs and data.
- The **ROM** (read-only memory) contains the Applesoft BASIC language, machine language Monitor, and the enhanced video firmware.
- The **Memory Management Unit** (MMU) contains most of the logic that controls memory addressing.
- The **Input/Output Unit** (IOU) contains most of the logic that controls the built-in input and output ports.
- The **Integrated Woz Machine** (IWM) is a self-contained disk controller card on a single integrated circuit. This IC supports both 3.5- and 5.25-inch disk drives.
- Two **6551 Asynchronous Communication Interface Adapters** (ACIA) handle the information to be sent and received through the two built-in serial ports.
- The **3600PRO Keyboard Encoder** interprets data sent from the keyboard when a key is pressed.
- The **Oscillator** (timing device) generates the master clock pulse. This master pulse is sent to two custom components, which break down the clock pulse and send it to various ICs on the logic board.
- A **Memory Expansion Connector** allows you to add a Memory Expansion Card containing up to 1 Megabyte of RAM. This brings total system memory to 1.15 Megabytes.

AC Power Pack

Power is supplied by the AC Power Pack (Figure 3-A), which converts AC voltage into 15 volts DC. The DC voltage is sent to a 7-pin DIN connector on the rear of the computer.

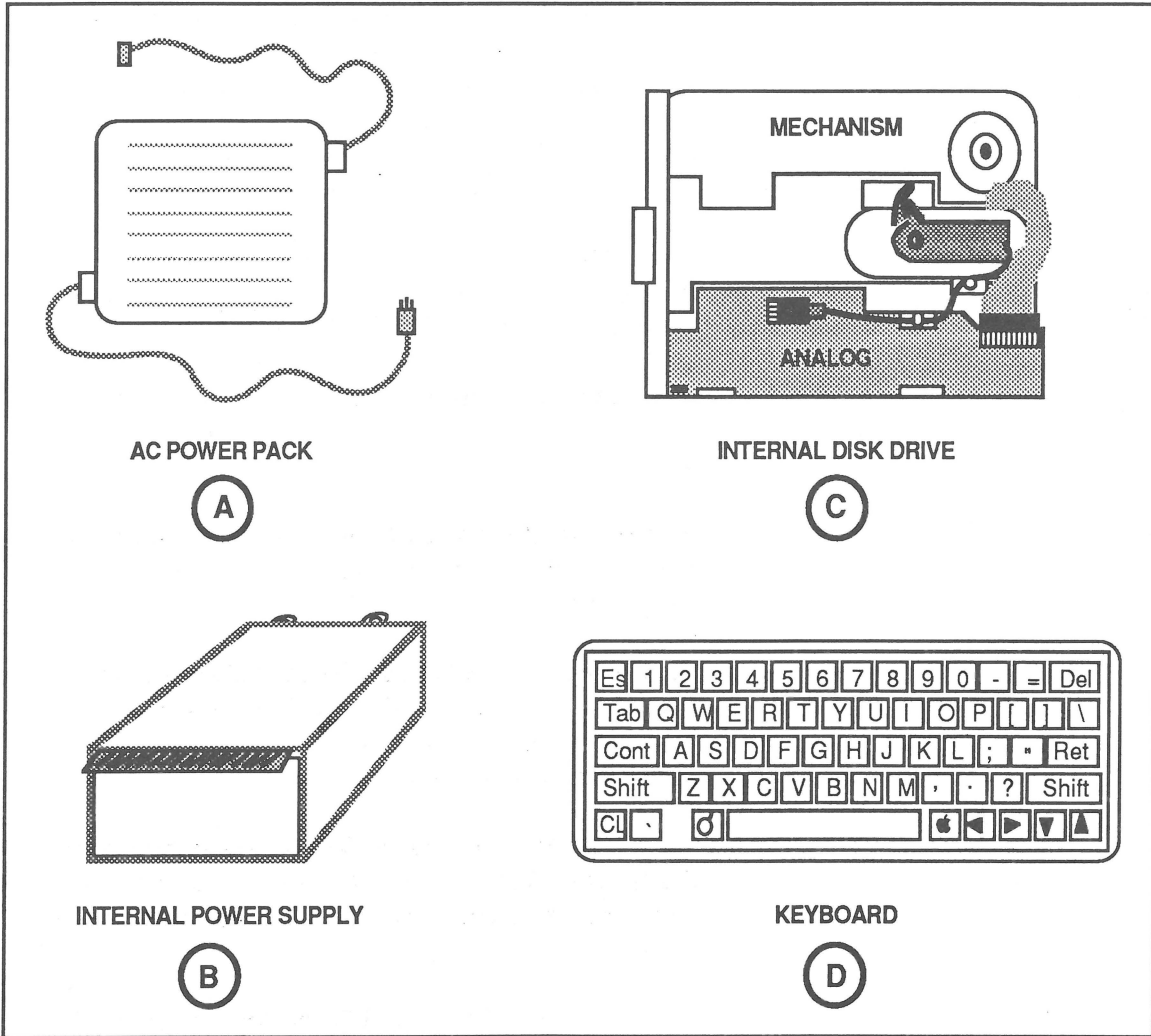

FIGURE 3

Internal Power Supply

The internal power supply (Figure 3-B) uses the 15 volts DC from the AC Power Pack to generate the DC voltages needed by the system.

Internal Disk Drive

The internal disk drive (Figure 3-C) is composed of two exchangeable modules: the analog card and the mechanical assembly.

The **analog card** interprets the instructions from the logic board and lets the mechanical assembly know what to do. The **mechanical assembly** rotates the diskette and moves the read-write head over the proper area on the diskette for reading or writing.

Keyboard

The keyboard (Figure 3-D) is a matrix of keyswitches connected to the logic board via a ribbon (flat) cable. The 3600 PRO keyboard encoder IC on the logic board translates the information from the keyboard into signals that the logic board can use.

❑ ELECTROSTATIC DISCHARGE (ESD) PRECAUTIONS

Electrostatic Discharge (ESD) can cause severe damage to sensitive microcircuits. Just touching a chip or brushing it with a nylon sleeve can degrade a circuit so that it never again performs to specification. Some microcircuits are sensitive to as little as 500 volts, or about one-sixth as much static electricity as you can feel.

Certain preventive measures must be taken to avoid ESD damage. When you are unwrapping, installing, or replacing any microcircuits, observe the following precautions:

Grounds

Before working on any device containing a printed circuit, ground yourself and your equipment to an earth or building ground.

Use a grounded conductive workbench mat and a grounding wriststrap, and ground your equipment to the mat.

Bodies

Don't touch anybody who is working on integrated circuits.

If that person is properly grounded, your "zap" may not cause any damage, but just to be on the safe side, keep your own body charge away from other technicians.

Bags

Use antistatic bags for boards and chips during handling.

Whenever you are about to leave your bench and take a board to a storage place, first put the board in an antistatic bag. Leave all Apple service exchange components in their ESD-safe packaging until needed for use.

Leads

Handle all ICs by the body, not the leads.

Also, do not touch PCB edge connectors, exposed circuitry, or printed circuits. Handle ICs and PCBs by the edges, or use extractors.

Synthetics

Do not wear polyester clothing or bring plastic, vinyl, or styrofoam into the work environment.

The electrostatic field around these nonconductors cannot be removed.

Metals

Never place components on any metal surface.

Use antistatic or conductive mats or foam.

Atmosphere

If possible, keep the humidity in the service area between 70% and 90%, and use an ion generator.

Charge levels are reduced (but not eliminated) in high humidity environments and in areas where an ion generator is used routinely.

Apple IIc

Section 2 – Take-Apart

□ CONTENTS

- 2.3 Electrostatic Discharge Precautions
- 2.4 Top Cover
- 2.6 Keyboard and Memory Expansion Card
- 2.8 Disk Drive
- 2.9 Analog Card
- 2.12 Mechanical Assembly
- 2.12 Bezel, Door, and Spring Assembly
- 2.14 Internal Power Supply
- 2.15 Speaker
- 2.17 Logic Board
- 2.18 Volume Control
- 2.19 Power Switch

Note: If a step is underlined, detailed instructions for that step can be found elsewhere in this section.

□ ELECTROSTATIC DISCHARGE PRECAUTIONS

Electrostatic discharge can be an important factor in causing board failures: even if the failures are not immediate and dramatic, static zaps can degrade chips in such a way that they fail weeks or months after exposure.

Be sure to follow the ESD prevention information located in Section 1, Basics, to avoid damage to any Apple II electronics.

□ TOP COVER

Materials Required

#2 Phillips screwdriver
Jeweler's screwdriver

Remove

1. Turn off the power and disconnect all cables from the back of the computer.
2. Move the handle into carrying position.
3. Turn the computer upside down.
4. Remove the six case screws (Figure 1, #1).
5. If you are replacing the disk drive, logic board, volume control, or power switch, also remove the disk drive mounting screws (Figure 1, #2).

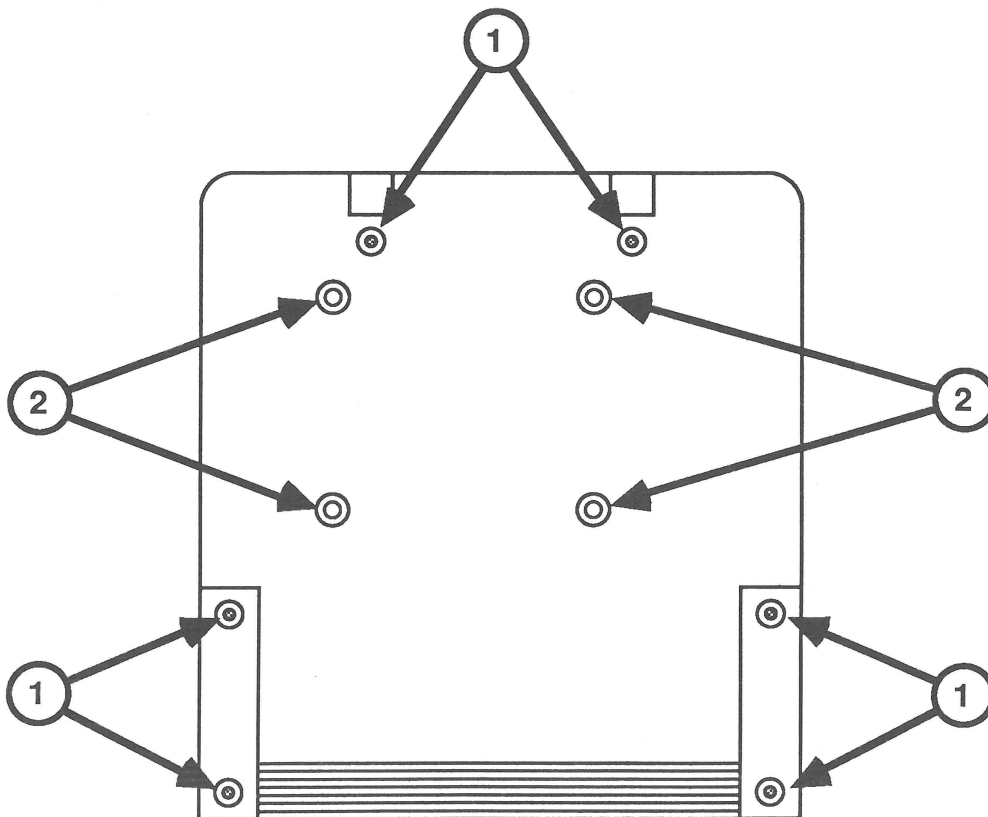

FIGURE 1

6. Hold the case together and turn it over (keyboard face up) with the keyboard toward you.
7. Grasp the sides of the IIc at the front so that your thumbs meet in the front center of the top cover.
8. Press back and up with your thumbs while gripping the sides of the case, so that the top cover flexes and the snaps come free.

If you have difficulty with this, insert the tip of the screwdriver in the front center of the case between the top cover and base. Then move the end of the screwdriver up. This will undo the snap at the front of the cover and allow you to lift the cover with your fingertips.

Note: In addition to the snap at the front center of the top cover, there is one snap on each side of the disk drive door. You will feel resistance from them, but don't worry: just pull the cover off.

9. Remove the handle and lay it aside.

Replace

1. If the handle is not already in place, snap it into the grooves in the back of the computer.
2. Make sure the keyboard is properly seated in the grooves in the side of the disk drive shield and within the plastic guides that surround it.
3. Fit the top cover onto the base. Make sure it snaps into place at the two back corners, on either side of the disk drive door, and at the center of the front edge.
4. Turn the computer over and replace the screws as follows:
 - a) The four large-head flat-nose screws attach the disk drive to the case.
 - b) The six small-head pointed-nose screws hold the case together.

□ KEYBOARD AND MEMORY EXPANSION CARD

Materials Required

Needlenose pliers

Remove

1. Remove the top cover.
2. Lift the front of the keyboard up and forward. Rest the keyboard upside-down on the disk drive.

If a Memory Expansion Card is **not** installed, skip to step 5.

3. Using the needlenose pliers, squeeze each of the four nylon clips securing the Memory Expansion Card to the stand-offs (see Figure 2, #1), and simultaneously lift the edge of the board nearest that stand-off. Start with the stand-off in the upper-left corner of the board and work counter-clockwise. To avoid causing damage to the printed circuit board, hold the pliers straight up.
4. Lift the Memory Expansion Card straight up and lay it aside.
5. Disconnect the keyboard cable connector from the logic board.

Replace

1. Rest the keyboard upside down on the disk drive.
2. Connect the cable from the keyboard to the logic board.

If a Memory Expansion Card is **not** installed, skip to step 5. If a Memory Expansion card **is** installed, continue with step 3.

3. Prior to installing a new keyboard in the computer, verify that four rubber feet have been installed on the solder side of the keyboard. If there are no rubber feet present, refer to "Memory Expansion Card Installation" in section 6, Additional Procedures, for placement information.

4. Place the Memory Expansion Card on the four nylon stand-offs, component side down and with the connector at the right side. **Gently** press down on the card starting at the connector side and then at each stand-off on the left side.
5. Slide the back edge of the keyboard into the slots in the side of the disk drive shield. Make sure the keyboard is seated inside the plastic guides that surround it.
6. Replace the top cover.

Note: Refer to *You Oughta Know* for replacement of individual keyswitches.

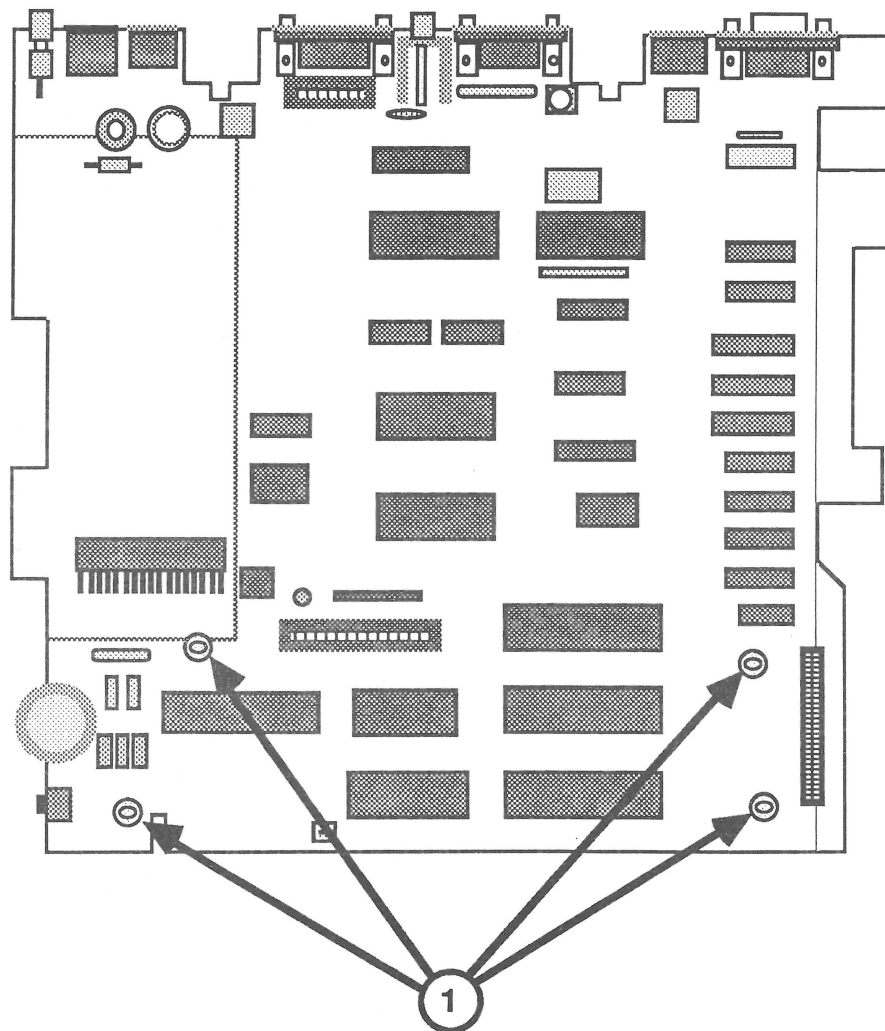

FIGURE 2

□ DISK DRIVE

Materials Required

#2 Phillips screwdriver

Remove

1. Remove the top cover, including the four disk drive screws, and place the IIC on your work surface.
2. Lift the disk drive up and back. Place it upside down on the table behind the computer.
3. Disconnect the disk drive cable connector from the logic board.

Replace

1. Attach the disk drive cable connector to the logic board.
2. Place the disk drive in the case. Line up the disk drive door with the cutout in the case, the ground clip with the keyboard, and the tab on the keyboard with the slot in the disk drive shield.
3. Replace the top cover.

□ ANALOG CARD

Materials Required #2 Phillips screwdriver

- Remove**
1. Remove the disk drive.
 2. Remove the cable from the disk drive (Figure 3, #1).
 3. Remove the four Phillips screws, two from either side of the disk drive shield.
 4. Pull up on the shield to remove it from the disk drive.
 5. On the analog card, disconnect the cable from connector J2 (Figure 3, #2).

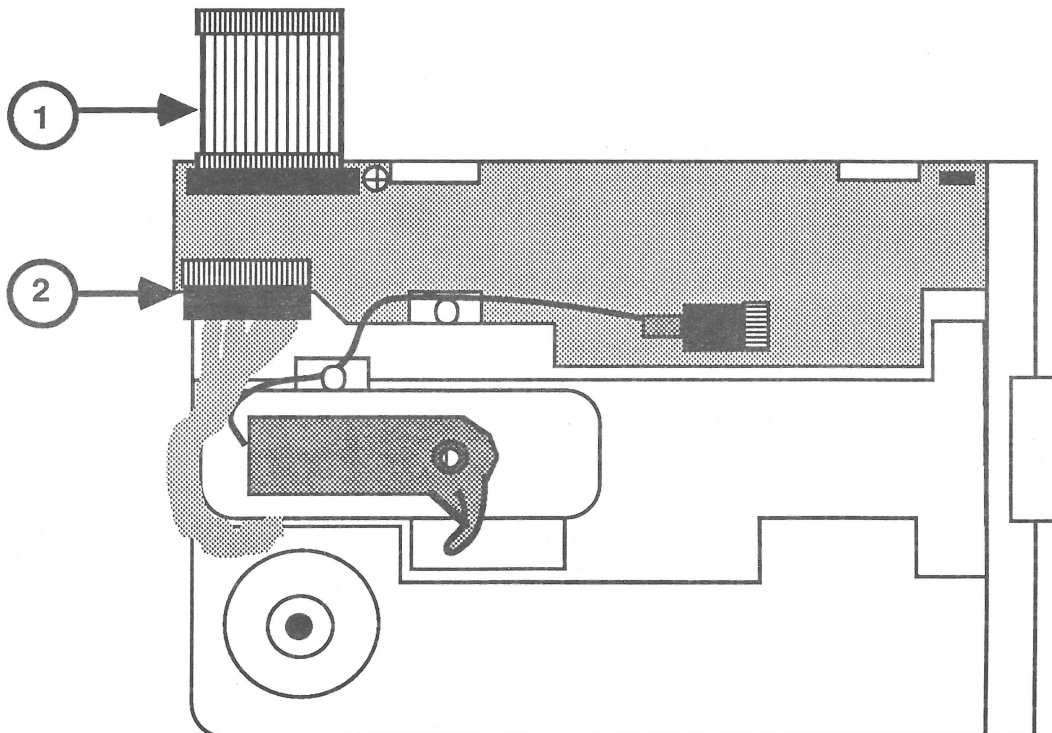

FIGURE 3

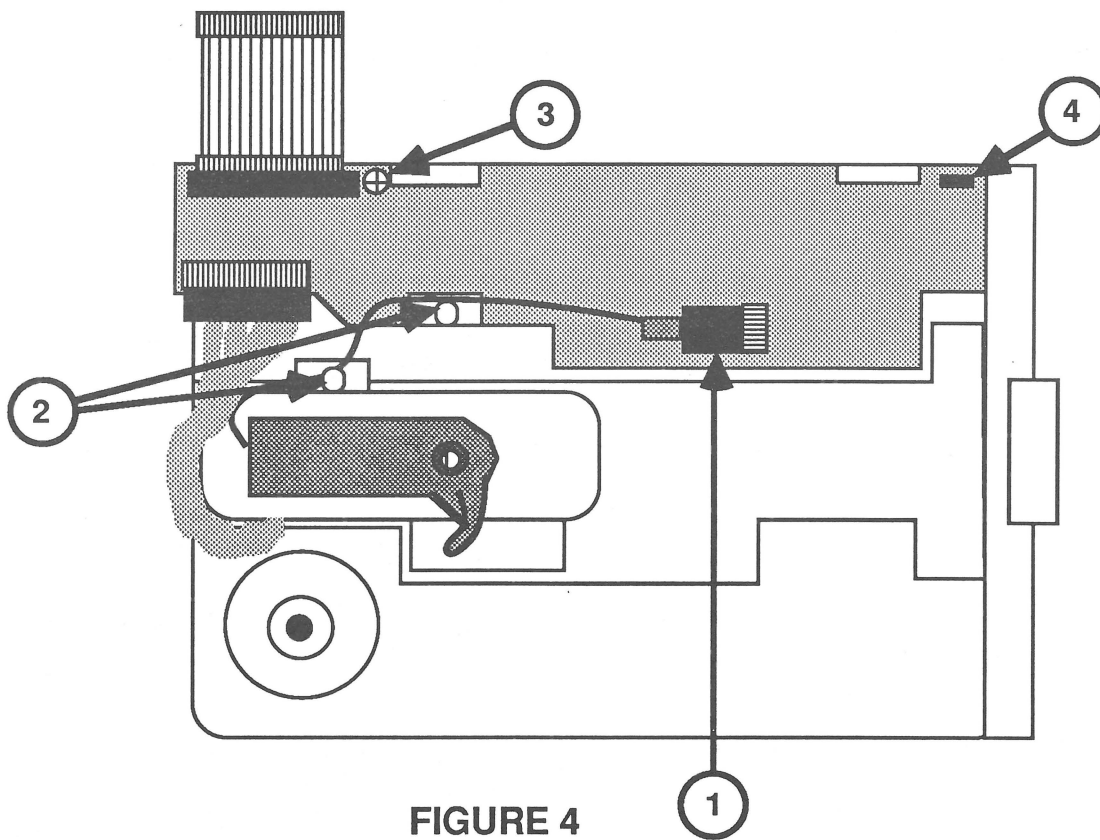

FIGURE 4

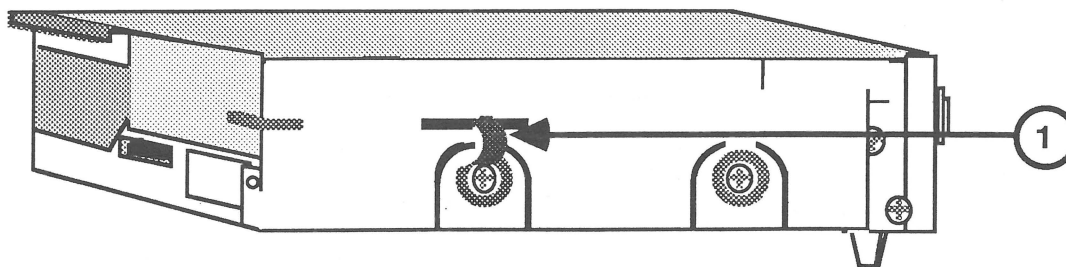

FIGURE 5

6. On the analog card, disconnect the cable from connector J3 (Figure 4, #1) and carefully remove the wire from the clips (Figure 4, #2).
7. Remove the Phillips screw that mounts the analog card to the disk drive chassis (Figure 4, #3).
8. Tilt the rear edge of the analog card slightly up, and slide the card away from the disk drive.

Replace

1. Slide the front edge of the card under the two plastic posts located on the inside of the disk drive bezel. Lay the card on the chassis so that the alignment tab (Figure 4, #4) protrudes through the hole.
2. Replace the Phillips mounting screw.
3. Look at the read/write head cable (Figure 4, #1) that attaches to connector J3, and note that only four wires are connected to the five-pin connector. Connect the read/write head cable, making sure that each wire makes contact with a pin on the header.
4. Position the wire and, if necessary, carefully bend the clips to hold it in place.
5. Connect the motor cable to connector J2. The cable should be oriented so that the end of the connector with the single wire is toward the rear of the disk drive.
6. Replace the shield and corresponding Phillips screws. Make sure the ground clip is installed at the left-front position (Figure 5, #1).
7. Replace the disk drive flat cable. Orient the cable so that the red stripe is at the rear of the disk drive.
8. Replace the disk drive.

□ MECHANICAL ASSEMBLY

Materials Required #2 Phillips screwdriver

Remove

1. Remove the analog card.
2. Replace the shield if returning the mechanical assembly to Apple for exchange.

Note: The disk drive shield must be installed on the mechanical assembly when the disk drive is sent to Apple for exchange. Also, be sure to remove the LED cable.

Replace

1. Remove the shield if present.
2. Replace the analog card.

□ BEZEL, DOOR, AND SPRING ASSEMBLY

Materials Required #2 Phillips screwdriver

Remove

1. Remove the disk drive.
2. Remove the flat cable from the disk drive.
3. Remove the four Phillips screws, two from either side of the disk drive shield.
4. Pull up on the shield to remove it from the disk drive.
5. Remove the four Phillips screws that attach the bezel to the disk drive (two screws on each side).
6. Open the disk drive door by pushing inward. As you pull the bezel from the disk drive, hold on to the spring. It is not firmly attached and may fall out.

7. To remove the door from the bezel, simultaneously push it forward and rotate the rear edge up. Now pull it backward out of the bezel.
8. Remove the spring from the door.

Replace

1. Put the door in the bezel (Figure 6, detail A).
2. Hold the door and bezel together. Slide the projecting part of the door partway into the grooves of the hub frame (Figure 6, detail B).

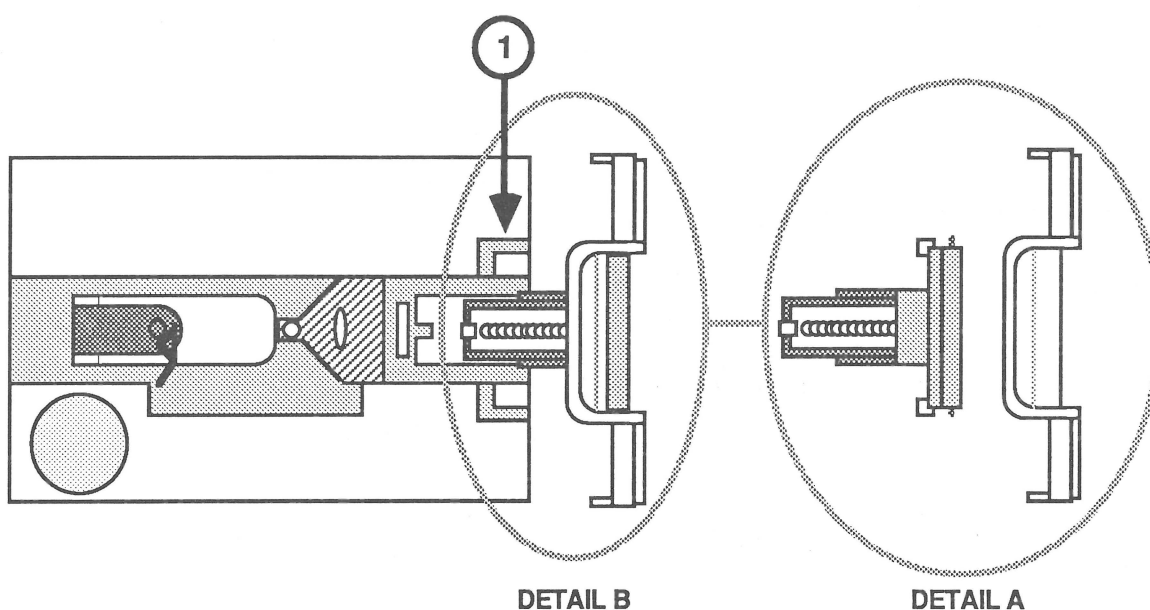

FIGURE 6

3. As you fit the bezel onto the disk drive:
 - a) Push down the hub frame so that its aluminum arms (Figure 6, #1) fit under the top edge of the bezel.
 - b) If the analog card is present, make sure that it is held in place under the two tiny posts on the inside of the bezel.
4. Install the spring. (Hint: Put one finger under the disk drive door to guide the spring.)

5. Close the disk drive door and put the bezel into place.
6. Replace the Phillips screws that attach the bezel to the disk drive.
7. Replace the shield and corresponding Phillips screws. Make sure the ground clip is installed at the left-front position.
8. Replace the flat cable. Orient the cable so that the red stripe is at the rear of the disk drive.
9. Replace the disk drive.

□ INTERNAL POWER SUPPLY

Materials Required

#2 Phillips screwdriver

CAUTION: Make sure the power cord has been disconnected from the rear of the computer.

Remove

1. Remove the top cover.
2. Remove the two screws that mount the power supply to the case.
3. Tip the back of the power supply up a little and pull the power supply from the connector.

Replace

1. Slide the power supply into the connector.
2. Install the two screws that mount the power supply to the case.
3. Replace the top cover.

□ SPEAKER

Materials Required

#2 Phillips screwdriver
Jeweler's screwdriver
Sharp razor blade with handle

Remove

1. Remove the keyboard.
2. Use the razor to cut the glue securing the speaker to the case. Be careful not to damage the speaker, its wires, or the logic board.
3. Insert a small screwdriver under the rear lip of the speaker and pop it out of its plastic retaining clips.

Replace

1. Place the speaker so that the wires are toward the bottom of the IIC case and the top lip is under the top plastic clip on the case.
2. Press on the bottom lip until it pops under the two lower clips.
3. Replace the keyboard.

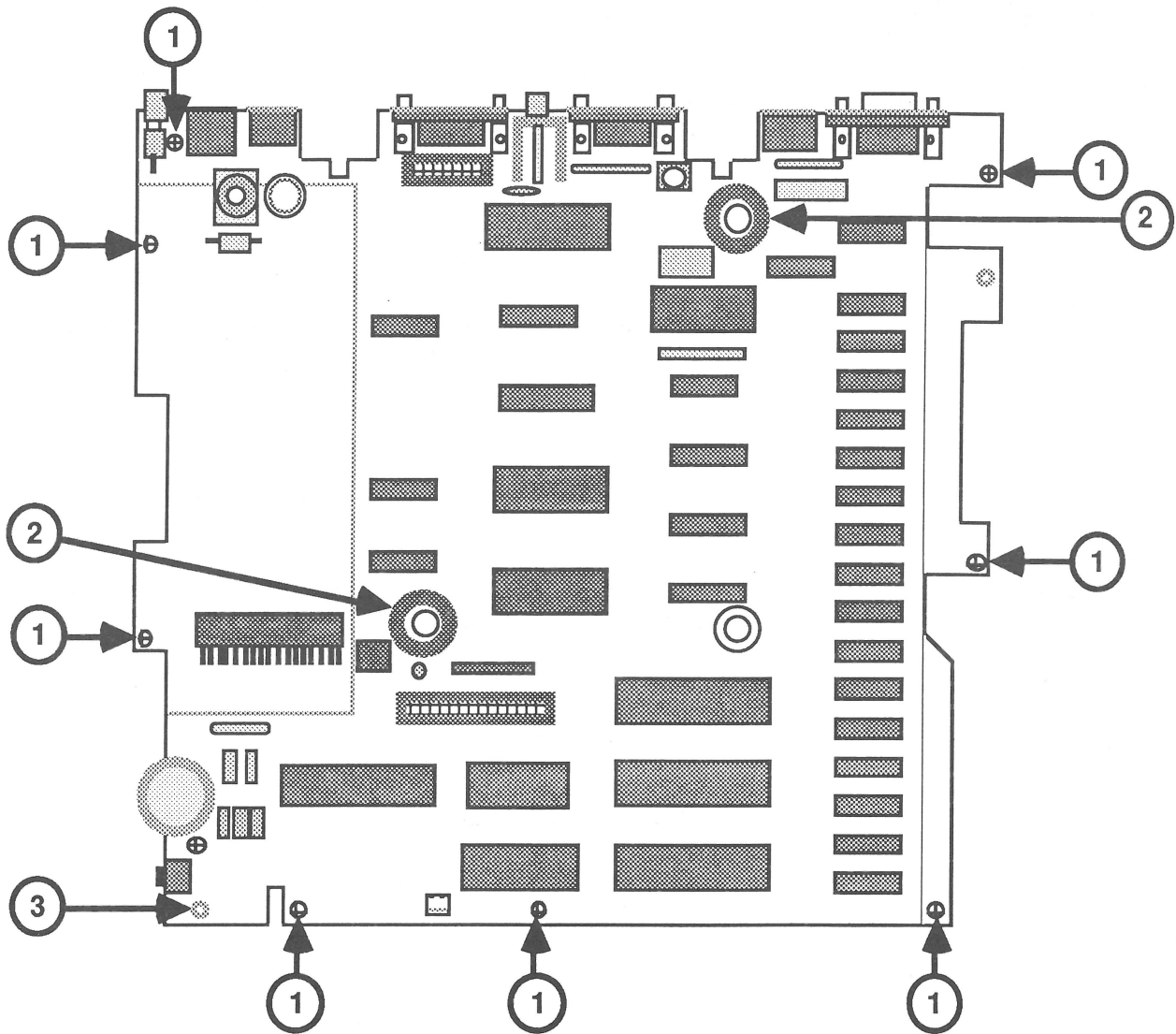

FIGURE 7

□ LOGIC BOARD

Materials Required

#2 Phillips screwdriver

Remove

1. Remove the top cover.
2. Remove the keyboard and Memory Expansion Card (if present).
3. Remove the disk drive.
4. Remove the internal power supply.
5. Disconnect the speaker cable.
6. Remove the screws that attach the logic board to the case (Figure 7, #1). Depending on the version of logic board installed, there will be either eight or nine screws.
7. Remove the two wire-mesh toroids (Figure 7, #2).
8. Carefully remove the logic board by lifting it off its posts and then pulling it out to the right. Be careful of the small post at the front, near the headphone connector (Figure 7, #3).

Replace

Note: Prior to installing a new logic board in the computer, verify that three rubber feet have been installed on the solder side of the board. If there are no rubber feet present, refer to "Logic Board Rubber Feet Installation" in Section 6, Additional Procedures, for installation instructions.

1. Slide the logic board into place, left side first, making sure the headphone connector is properly seated and that the board is seated on all posts.
2. Connect the speaker cable.
3. Replace the two wire-mesh toroids on their posts.

Note: The toroids must be on the correct posts to ground the disk drive.

4. Install the screws that attach the logic board to the case. Start each screw before tightening them down
5. Replace the internal power supply.
6. Replace the disk drive.
7. Replace the keyboard and Memory Expansion Card (if applicable).
8. Replace the top cover.

□ VOLUME CONTROL

Materials Required

#2 Phillips screwdriver
Soldering iron
60/40 Rosin core solder
Desoldering tool

CAUTION: *If you are not familiar with basic soldering skills, DO NOT attempt this procedure.*

Remove

1. Remove the logic board.
2. Locate the volume control on the logic board. Turn the logic board over and carefully desolder the three volume control leads.
3. Turn the logic board over again (component side up) and remove the volume control.

Replace

1. Insert the three leads of the volume control into their respective solder holes on the logic board.
2. Hold the knob in place as you turn the logic board over. Position the logic board so that the interface connectors and the two capacitors (near the power switch) hang over the edge of the desk. Allow the volume control to rest against the top of the work surface.
3. Solder the three volume control leads to the logic board.

3. Solder the three volume control leads to the logic board.
4. Check to see that there are no cold solder joints and that the body of the control is flush against the logic board.
5. Replace the logic board.

□ POWER SWITCH

Materials Required

#2 Phillips screwdriver
Soldering iron
60/40 Rosin core solder
Desoldering tool

CAUTION: *If you are not familiar with basic soldering skills, DO NOT attempt this procedure.*

Remove

1. Remove the logic board.
2. Orient the logic board so that the interface connectors are facing away from you.
3. Locate the power switch at the upper left corner of the board.
4. Turn the logic board over and desolder the five leads coming from the power switch.
5. Turn the board over again (component side up) and remove the switch. If the switch offers too much resistance, gently rock it back and forth until it is loose enough to be easily removed.

Replace

1. Insert the five leads from the power switch into their respective solder holes in the logic board.
2. Hold the switch against the logic board so that the body of the switch remains flush against the board. Turn the board over.
3. Solder the five leads to the logic board.
4. Check to see that there are no cold solder joints, and that the body of the switch is flush against the logic board.
5. Replace the logic board.

Apple IIc

Section 3 – Preventive Maintenance

☐ CONTENTS

- 3.2 Introduction
- 3.2 Disk Drive Read/Write Head
- 3.3 Disk Drive Head Load Button

□ INTRODUCTION

The preventive maintenance procedures for the IIc all relate to the internal and external disk drives. The read/write head should be cleaned any time the computer or disk drive is being serviced. The head load button should be replaced whenever it is worn or dirty.

□ DISK DRIVE READ/WRITE HEAD

Materials Required

Cotton swabs
Isopropyl Alcohol (80% alcohol/20% water)

Procedure

1. Remove the disk drive. (see Section 2, Take-Apart or, for the external drive, "Disk Drive" in *Disk IIc Technical Procedures*, Section 1, Take-Apart.)
2. Remove the four screws, two from either side of the disk drive shield.
3. Pull up on the shield to remove it.
4. Clean the guide rails with the isopropyl alcohol. **Do not** use grease.
5. Inspect the head for worn or dull spots in the ceramic. If you find any, replace the mechanical assembly. See Section 2, Take-Apart.
6. Clean the head with the isopropyl alcohol.
7. Inspect the motor drive belt for cracks, slippage, and elasticity. If the belt is dry or cracked, or if it slips, replace the mechanical assembly. See Section 2, Take-Apart.
8. Move the read/write head assembly back and forth along the full length of its travel. Check for any blockage or friction. If there is any, replace the mechanical assembly. See Section 2, Take-Apart.

□ DISK DRIVE HEAD LOAD BUTTON

Check the head load button for contamination and wear. If the button is worn or dirty, replace it.

Materials Required

Needlenose pliers
Head load button

Procedure

1. Remove the disk drive. See Section 2, Take-Apart.
2. Remove the four screws, two from either side of the disk drive shield.
3. Pull up on the shield to remove it.
4. Lift up the head load arm. If the head load button is worn or dirty, squeeze the top part of the load button with small needlenose pliers and let the button drop down.
5. Insert the new load button through the hole in the shield plate and into the head load arm. Press the button until it snaps into place.
6. Replace the drive shield, ground clip, and corresponding screws.
7. Replace the disk drive. See Section 2, Take-Apart.

Apple IIc

Section 4 – Diagnostics

□ CONTENTS

4.2	Introduction
4.3	Things to Remember
4.3	Before You Begin
4.3	Setting Up
4.4	While Testing
4.5	Built-In Diagnostic
4.5	Running the Diagnostic
4.5	Results
4.6	Apple IIc Diagnostic Diskette
4.6	Materials Required
4.6	Main Menu
4.7	Choose Tests
4.10	Options
4.10	Special
4.11	Running the Diagnostics
4.15	Test Failures

□ INTRODUCTION

This section describes general procedures for using the Apple IIc Diagnostic, either 5.25- or 3.5-inch, on the Apple IIc. This diagnostic allows you to select the tests you wish to run and the order in which you wish to run them. It also allows you to run a continuous test, which is valuable for pinpointing the causes of intermittent failures.

Note: The 3.5-inch diskette can also run on the Apple IIGs™ and the Apple IIe. The 5.25-inch diskette can run on the Apple IIe. Refer to the *Apple IIGs and Apple IIe Technical Procedures* for more information.

□ THINGS TO REMEMBER

Before You Begin

1. Make a backup diskette before beginning! When testing a defective Apple IIc, it is possible to erase and damage sections of the diskette. Use *System Utilities* (revision 2.1.1 or higher) to make the backup copy.
2. Before you boot the diskette-based diagnostics, run the built-in diagnostics.
3. The diagnostic can be run from either the internal 5.25-inch disk drive or an external UniDisk 3.5.
4. Make sure the keyboard switch is not depressed (Sholes layout). If it is, the keyboard diagnostic will not work correctly.

Setting Up

1. If you are going to select the **Serial External Test**, the loopback cable must be installed.
2. If you are going to select the **Apple IIc Memory Expansion Card Test**, the memory card must be installed and selected. Refer to Section 6, Additional Procedures, for more information.
3. To select a test, type the letter or use the arrow keys until the name of the test is highlighted; then press <Return>.
4. When chosen, each test displays a number (1, 2, 3, etc). This number indicates the order in which the test will be performed.

5. To deselect a test, type the letter or use the arrow key until the name of the test is highlighted; then press the <Delete> key. The test sequence numbers displayed will be corrected automatically. To deselect all tests, press <Open-Apple> and <Delete>.
6. To access the **Help** screen, hold down <Shift> and <Open-Apple> and press ?.

While Testing

1. Where input is required to start the next test (after video tests, for example), press <Space>.
2. To abort any test, press <Escape>. The testing will stop upon completion of the test in progress.
3. If you select the looping function and have selected a test that needs a loopback cable or card (Serial External Test, External Memory Card RAM Test) and the cable or card is not installed, you will receive an error code.
4. When running the Character Generator Test and using a ColorMonitor IIc or AppleColor™ Monitor IIc, the video display shifts left and right and toggles between color and monochrome. (This is the normal result of the method used to display the Character Set Test.)

To make the display easier to view, depress the White Only switch during the Character Generator Test, and release the switch during all other tests.

□ BUILT-IN DIAGNOSTIC

Before you boot the diskette-based diagnostics, run the built-in diagnostic. This will verify that the RAM, ROM, MMU, and IOU are functioning correctly.

Running the Diagnostic

To run the built-in diagnostic, hold down the <Open-Apple> and <Closed-Apple> keys while turning on the power. (To run them when the power is already on, hold down the <Control><Open-Apple><Closed-Apple> and <Reset> keys. Release the <Reset> key first, then the other keys.)

The screen will display various patterns and colors for approximately one minute. The RAM, ROM, MMU, and IOU circuitry on the logic board are being tested.

Results

The results, shown in the center of the display, will be either **System OK** (accompanied by a high-toned beep) or the name of the failed component (with a low-toned beep).

Test Passed

If you can access the built-in diagnostics and you receive the message **System OK**, continue with this section.

Test Failed

If you cannot access the built-in diagnostics or you receive a message other than **System OK**, exchange the logic board and try again.

□ APPLE IIc DIAGNOSTIC DISKETTE

Materials Required

Apple IIc Diagnostic diskette
Video display and cable
Serial Loopback Cable (required for Serial External Test)
Apple IIc Memory Expansion Card (required for Memory Expansion Card Test)
AppleMouse™ IIc (Optional)
Hand Controllers II (Optional)
Joystick II (Optional)

Main Menu

The *Apple IIc Diagnostic* main menu is shown below.

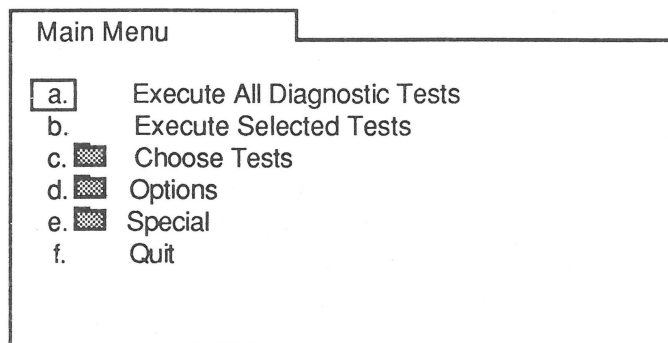

The following is a list of each item in the main menu, along with a brief description of what it is used for.

Execute All Diagnostic Tests – Runs the standard tests for the Apple IIc.

Execute Selected Tests – Runs the tests selected in **Choose Tests**.

Choose Tests – Contains all the tests that can be selected for the Apple IIc. Used to select one or more tests for customized testing.

Options – Contains various selections that allow you to control how the tests are run.

Special – Contains various options for keeping track of errors generated, for saving a test sequence, and for loading a test sequence from a diskette.

Quit – Stops all testing and reboots the system.

Choose Tests

The **Choose Tests** folder is shown below.

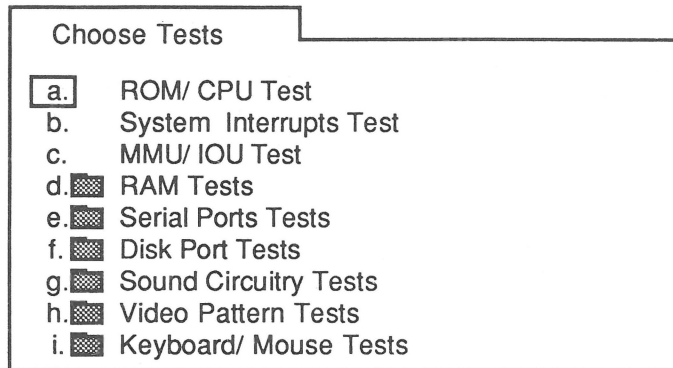

The following is a list of each item in the **Choose Tests** folder, along with a brief description of each.

ROM/CPU Test – Checks the ROM and CPU.

System Interrupts Test – Checks that interrupts are functioning correctly.

MMU/IOU Test – Checks the Memory Management Unit and the Input/Output Unit.

RAM Tests Folder

RAM Tests – This folder contains the following:

- Main Logic Board RAM Test – Checks the 128K on the logic board.
- Apple IIc Memory Expansion Card Test – Checks the RAM on an Apple IIc Memory Expansion Card (if installed). Testing takes approximately 45 seconds for each 256K. Refer to Section 6, Additional Procedures, for more information.

Serial Ports Folder

Serial Ports Tests – This folder contains the following:

- Serial Internal Test – Checks the logic board circuitry that handles the serial ports.
- Serial External Test (Loopback cable is required) – Checks the ports to be sure they are sending and receiving data correctly.

*Disk Port
Folder*

Disk Port Tests – This folder contains the following:

- Disk Port Test – Checks the drive circuitry on the logic board for all 3.5- or 5.25-inch drives that are attached to the system. The diskette in the drive being tested must be ProDOS® formatted.

*Sound Circuitry
Folder*

Sound Circuitry Tests – This folder contains the following:

- Speaker Tone Test – Checks the speaker by playing a sequence of beeps.

*Video
Pattern Folder*

Video Pattern Tests – This folder contains the following:

- Color Bar Test – Displays vertical color bars with the name of each color below.
- Character Generator Test – Displays the full character set.

Note: When running the Character Generator Test and using a ColorMonitor IIc or Composite Monitor IIc, the video display shifts left and right and toggles between color and monochrome. (This is the normal result of the method used to display the Character Set Test.)

To make the display easier to view, depress the White Only switch during the Character Generator Test, and release the switch during all other tests.

- 80/40 Column Text Test – Displays 15 lines of characters. When the 40/80 column switch is depressed, 40 columns are displayed. When the switch is released, 80 columns are displayed.
- Low Resolution Graphics Test – Displays both pages (one and two) of low-resolution graphics with bars at the top of the screen.
- High Resolution Graphics Test – Displays both pages (one and two) of high-resolution graphics using a grid of 9 vertical lines intersected by 8 horizontal lines.
- Double High Resolution Graphics Test – Displays a grid of 18 vertical lines intersected by 8 horizontal lines.

*Keyboard/Mouse
Folder*

Keyboard/Mouse Tests – This folder contains the following:

- Keyboard Test – Displays a keyboard layout. The instructions are given at the bottom of the screen.
- Languages – Displays a list of languages available for the keyboard tests. The default setting is U.S.A. English.
- Mouse Test – Displays a pointer that can be moved around the screen and a box that indicates whether the mouse button is pressed or not.
- Joystick/Paddle Test – Displays a pointer that can be moved around the screen and a box that indicates whether the joystick/paddle buttons are pressed or not. If testing paddles, verify that both reach the full range possible (0-FF).

Options

When the **Options** folder is open, the following list of selections appears on the screen.

- Loop Tests Until ESC Is Pressed
- Continue On Error Until ESC

If an option is selected, a check mark appears beside the item. To deselect an option, just select the same option again.

Special

The following is a list of selections that appears when the **Special** folder is opened.

- Display Error Log – Displays the names of the tests that have failed since the last clearing of the error log (up to 255 names).
- Clear Error Log – Erases the error log from RAM.
- Clear Testing Status Line – Clears the iterations and failure counts displayed on the main menu.
- Display Current System Status – This indicates the type of system, the ROM version, the amount of memory available and whether a Memory Expansion Card is installed.
- Load Selected Test Sequence from Disk – This will load a previously saved test sequence. The sequence can then be executed.
- Save Selected Test Sequence to Disk – This will save a test sequence you have selected to the test diskette.

When any of these items is selected and <Return> is pressed, the action is performed.

Running the Diagnostics

The diagnostic program can be configured in various ways. All the tests can be run in their automatic sequence, or selected tests can be looped or run in an order you specify.

The diagnostic also has the ability to execute a test selection sequence that has been saved to the test diskette. Saved test sequences make it easier to test specific items that require non standard tests (see "Customized Tests," below).

Standard Test

1. Install the Serial Loopback Cable and the Memory Expansion Card, if available.

If they are not available, type N when the diagnostic asks you if they are installed. The testing will continue.

2. Insert the *Apple IIc Diagnostic* into either the internal or external disk drive. To run the diagnostic from the internal disk drive, turn on the computer. To run the diagnostic from the UniDisk 3.5, leave the internal drive door open.
3. Type the letter a or use the arrows to highlight **Execute All Diagnostic Tests**, and press <Return>.

To continue after certain tests (for example, Speaker or Video Patterns), press <Space>.

If an error is encountered, the testing will stop and an error message will be displayed in an alert box. Refer to "Test Failures" at the end of this section for the appropriate actions to perform.

4. On completion, the message **Testing finished** will be displayed in the alert box.

*Customized
Test*

1. If you are going to test the serial ports and the Memory Expansion Card, install the serial loopback cable and the memory card.
2. Insert the *Apple IIc Diagnostic* into either the internal or external disk drive. To run the diagnostic from the internal disk drive, turn on the computer. To run the diagnostic from the UniDisk 3.5, leave the internal drive door open.
3. Type the letter c or use the arrows to highlight **Choose Tests**, and press <Return>.
4. From this menu, use the letters or arrows to highlight the first three tests (if desired), and press <Return> to select them.

Use the letters or arrows to highlight the other test folders and press <Return> to display them. Use the letters or arrows to highlight the tests you wish to run from each folder and press <Return> to select them.

If you wish to deselect a test, use the letters or arrows to highlight the test and press the <Delete> key. To deselect all tests, press <Open-Apple> <Delete>.

Saving and Loading
Test Sequences

5. To save your customized test sequence, return to the main menu, and select **Special**. Select **Save Selected Test Sequence to Disk** and press <Return>.

You now have the selected test sequence saved on the diskette. The sequence may be loaded using **Load Selected Test Sequence From Disk** at a later date when it is needed.

6. On completion, return to the main menu, select **Execute Selected Tests**, and press <Return>.

To continue after certain tests (for instance, speaker or video patterns), press <Space>.

If an error is encountered, the testing will stop and an error message will be displayed in an alert box. Refer to "Test Failures" at the end of this section for the appropriate actions to perform.

7. On completion, the message **Testing Finished** will be displayed in an alert box.

Continuous Test

A continuous test is possible with all but the Keyboard/Joystick Tests. Select the tests you wish to loop by following the instructions under "Customized Test" (see above). Follow the steps below to run a continuous test.

1. After the diagnostic is configured, return to the main menu and select **Options**.

2. Select **Loop Tests Until Esc Is Pressed**

A check mark should appear indicating that it has been selected.

3. Selecting **Continue on Error until Esc** will cause the diagnostic to continue running regardless of an error until <Escape> is pressed. If you wish the diagnostic to stop on an error, make sure this option is not checked.

Errors will be logged to RAM.

4. Return to the main menu; select **Execute Selected Tests** and press <Return>.

The tests will run continuously (depending on your selection in step 3) until an error is encountered or <Escape> is pressed.

If you press <Escape> to stop the testing, you can then check for error codes by selecting **Special** followed by **Display Error Log**.

Highlight either the video display or the printer for a listing of the errors encountered.

5. If you are going to run the test again, be sure to clear the error log and the status line and to reselect **Loop Tests Until Esc Is Pressed** before returning to the main menu.

❑ TEST FAILURES

When a test fails, a message will be displayed indicating which one failed. The following is a list of the tests along with the recommended remedial actions for each if it fails.

Failed Tests

Remedial Action

- | | |
|-------------------------------|--|
| • <i>Rom/CPU</i> | – Exchange logic board. |
| • <i>System Interrupts</i> | – Exchange logic board. |
| • <i>MMU/IOU</i> | – Exchange logic board. |
| • <i>Main Logic Board RAM</i> | – Exchange logic board. |
| • <i>Extended Memory</i> | <ol style="list-style-type: none">1. Refer to Section 6, Additional Procedures, for more information.2. Exchange logic board. |
| • <i>Serial Internal</i> | <ol style="list-style-type: none">1. Refer to Section 6, Additional Procedures, "Logic Board Rubber Feet Installation."2. Exchange logic board. |
| • <i>Serial External</i> | <ol style="list-style-type: none">1. Refer to Section 6, Additional Procedures, "Logic Board Rubber Feet Installation."2. Verify that the loopback cable is installed.3. Exchange loopback cable.4. Exchange logic board. |

Failed Tests

Remedial Action

- *Disk Port*
 1. Verify that the diskette is inserted and the drive door is closed.
 2. Verify that the diskette is not write protected.
 3. Exchange logic board.
 4. Exchange disk drive.

- *Speaker Tone*
 1. Check volume setting.
 2. Check speaker connections.
 3. Exchange logic board.
 4. Exchange speaker.

- *Keyboard*
 1. Rerun test to verify results.
 2. Check keyboard switch position.
 3. Exchange keyboard.
 4. Exchange logic board.

- *Mouse*
 1. Check mouse connections.
 2. Exchange mouse.
 3. Exchange logic board.

- *Joystick/Paddle*
 1. Check joystick/paddle connections.
 2. Exchange joystick/paddle.
 3. Exchange logic board.

Apple IIc

Section 5 – Troubleshooting

☐ CONTENTS

5.2	Introduction
5.2	General Information
5.2	Before You Start
5.2	How to Use the Symptom Charts
5.3	Things To Remember
5.3	Symptom Chart
5.3	Video Problems
5.3	Drive Problems
5.3	Peripheral Problems
5.4	Miscellaneous Problems
5.5	Special Problem Symptom Chart

□ INTRODUCTION

General Information

These procedures provide guidelines for troubleshooting the Apple IIc personal computer using the following tools:

- Apple II Diagnostic Diskette
- Symptom/Corrective Action Charts

Before You Start

Read the section entitled "Things to Remember" before you begin troubleshooting. There are a number of things you should know about the Apple IIc to troubleshoot the system effectively.

How to Use the Symptom Charts

The *Symptom Chart* describes symptoms and appropriate steps to take to correct the failure. The *Special Problem Symptom Chart* describes unusual symptoms that may appear on older model Apple IIc computers (those with model number A2S4000).

When swapping out modules, remove the suspected faulty module and replace it with a known-good spare module from your service stock. If the problem still occurs, remove the replacement module, re-install the original module in the IIc, and try swapping out the next module on the list. Repeat the procedure until the problem no longer occurs. The module you replaced just before the problem disappeared is the faulty one. As a final check of the system, run the Apple II Diagnostic Diskette.

□ THINGS TO REMEMBER

1. Follow the basic ESD precautions when troubleshooting. (Refer to Section 1, Basics, for more information.)
2. Be sure the power is off before installing or removing any modules or components, or before connecting or disconnecting any peripheral devices.

□ SYMPTOM CHART

Video Problems

- *No video* – Exchange logic board.
- *Random monitor display*
 1. Exchange logic board.
 2. Exchange keyboard.

Drive Problems

- *Will not boot*
 1. Exchange disk drive.
 2. Exchange logic board.
- *No disk access*
 1. Exchange logic board.
 2. Exchange disk drive.
- *Continuous disk access*
 1. Exchange disk drive.
 2. Exchange logic board.

Peripheral Problems

- *Mouse problems*
 1. Exchange mouse.
 2. Exchange logic board.

- *Printer prints garbage*
 1. Verify configuration of printer port.
 2. Verify configuration of printer option switches.
 3. Is the correct cable being used?
 4. Refer to Section 6, "Logic Board Rubber Feet Installation."

Miscellaneous Problems

- *No power*
 1. Exchange AC power pack.
 2. Exchange internal power supply.
 3. Exchange logic board.

- *Applesoft BASIC errors*
 - Exchange logic board.

- *Stuck keys*
 - Exchange keyboard.

- *Programs run erratically, crash often*
 1. Exchange disk drive.
 2. Exchange logic board.

□ SPECIAL PROBLEM SYMPTOM CHART

Certain failures that occur on older model (A2S4000) IIc's can be solved using the symptom chart below. The left column lists the nature of the failure. The right column refers to the procedure in Section 6 that can be used to correct the failure.

- *Flashing screen or wavy lines on a IIc monitor* Section 6, AC Power Pack Upgrade
- *When using any serial printer or non-Apple modem:*
 - a. *lost characters*
 - b. *transmission errors*
 - c. *characters overrun each other.*Section 6, Serial Port Upgrade
- *IIc repeatedly fails to boot, or has difficulty reading or writing.* Section 6, Upper Head Shield Plate Installation
- *Power supply is turned "OFF" and the power supply turns back on by itself.* Section 6, Internal Power Supply Upgrade
- *Can't access UniDisk 3.5 disk drive.* Section 6, UniDisk 3.5 Compatibility

Apple IIc

Section 6 – Additional Procedures

□ CONTENTS

- 6.2 Apple IIc - Model A2S4100
- 6.2 Memory Expansion Card Installation
- 6.6 Diagnostics and Troubleshooting
- 6.9 Logic Board Rubber Feet Installation
- 6.10 Apple IIc - Model A2S4000
- 6.10 UniDisk 3.5 Compatibility
- 6.10 Serial Port Upgrade
- 6.10 AC Power Pack Upgrade
- 6.11 Internal Power Supply Shield Retrofit
- 6.12 Upper Head Shield Plate Installation
- 6.16 Internal Power Supply Upgrade
- 6.17 Expandable Logic Board Installation
- 6.20 Expandable Logic Board ROM Upgrade

Note: If a step is underlined, detailed instructions for that step can be found in Section 2, Take-Apart.

□ APPLE IIc - MODEL A2S4100

Memory Expansion Card Installation

The Apple IIc Memory Expansion Card can be used with any Apple IIc that has a logic board containing the memory expansion connector (see Section 1, Basics, "Theory of Operation"). This card supports the addition of RAM memory in increments of 256K, to a maximum of 1,024K (1 megabyte) with 256K as the minimum configuration available. (For further information on the features of the Memory Expansion Card, refer to the *Apple IIc Memory Expansion Card Owner's Manual*, which accompanies the card.)

Things to Remember

1. The Memory Expansion Card has ICs that are **highly susceptible to damage from electrostatic discharge**. Ground yourself by touching the internal power supply case before you pick up or install the Memory Expansion Card. To further prevent any damage from electrostatic discharge, place the board in an antistatic bag before carrying it anywhere.
2. The Memory Expansion Card exchange module is shipped configured with 256K of RAM. Any additional RAM is considered a replaceable part. 256K RAM chips are **highly susceptible to damage from electrostatic discharge**. Touch the internal power supply case before handling, removing, or installing the RAM chips. **Remember to remove any additional RAM from the board you are sending to Apple. Additional or defective RAM should not be sent in on the card.**

Configure the Memory Expansion Card

The Memory Expansion Card is shipped from Apple with 256K of RAM installed. To increase to 512K, 768K, or 1,024K, an appropriate number of *Apple II 256K Memory Expansion Kits* must be purchased and installed.

The RAM must be inserted in the correct sockets for the desired configuration. Remember to place the dot or indentation on the chip in the correct orientation for pin 1.

Only Apple RAM chips should be used. (Apple RAM has the letter *A* near pin 1.)

Install the RAM chips at their appropriate locations on the Memory Expansion Card. Refer to the Memory Configuration Chart for location information (Figure 1).

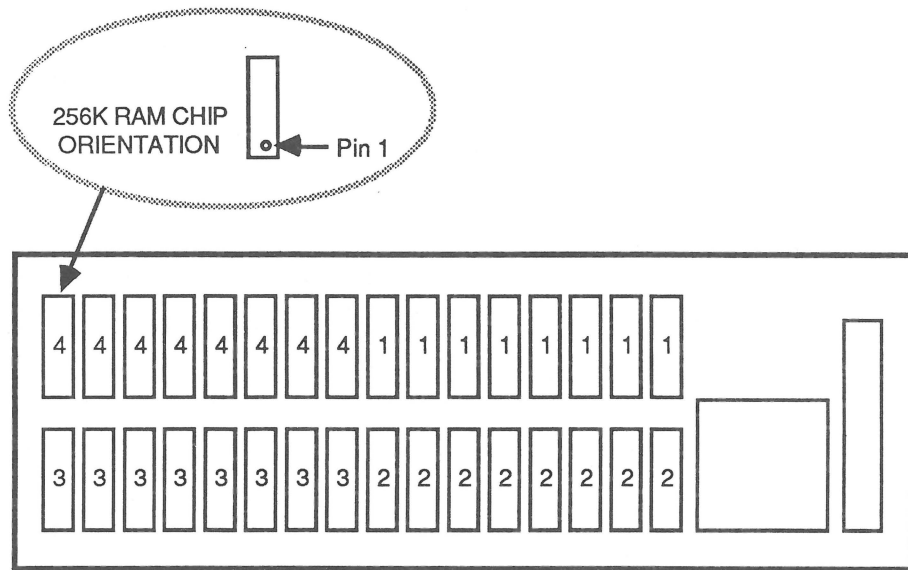

CARD SIZE	FILL BLOCK
256K	1
512K	1,2
768K	1,2,3
1024K	1,2,3,4

MEMORY CONFIGURATION CHART

FIGURE 1

Installation

Note: Apple IIc computers with model number A2S4100 have the connector and circuitry needed to install a Memory Expansion Card. Apple IIc computers with model number A2S4000 require a logic board upgrade **before** you install a Memory Expansion Card (see Section 6, Expandable Logic Board Installation).

1. Turn off the power and disconnect all cables from the back of the computer.
2. Remove the top cover.
3. Lift the front of the keyboard up and forward. Rest the keyboard upside down on the disk drive.
4. Insert the flared end of each stand-off into one of the four holes in the logic board, and press until it clicks into place. Repeat this for each of the three remaining stand-offs. Refer to Figure 2, #1 for stand-off locations.

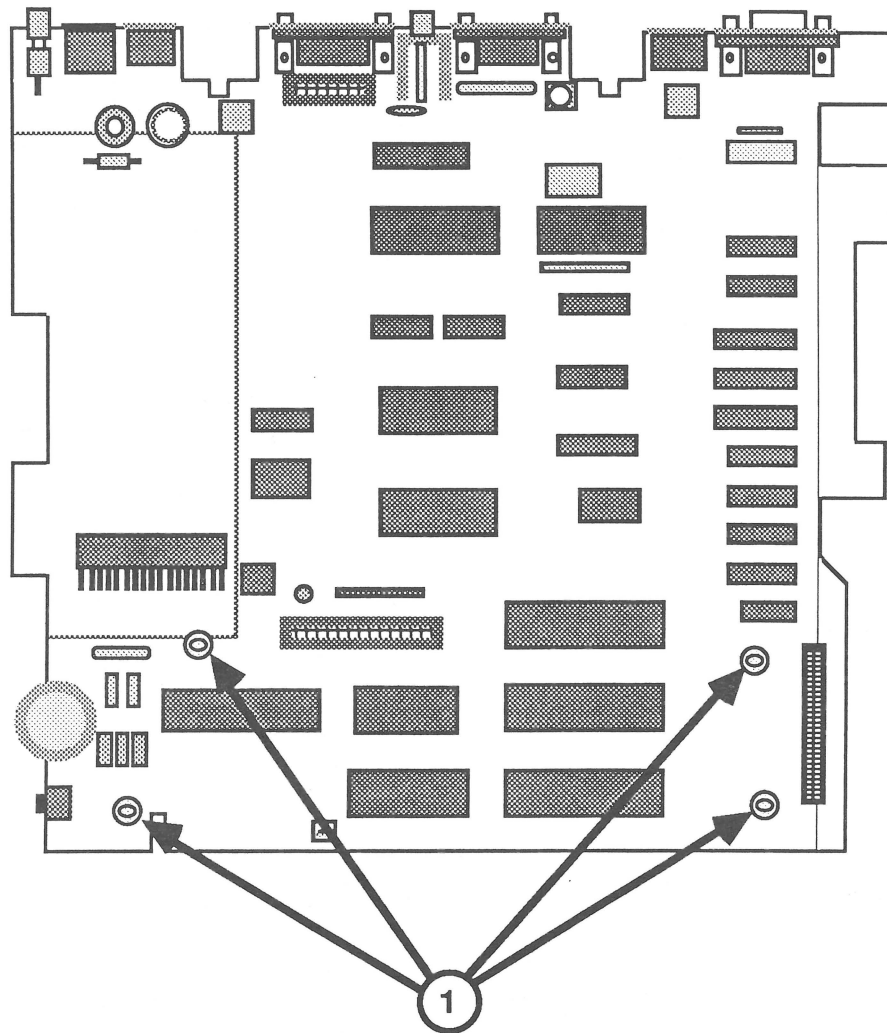

FIGURE 2

5. Install the four rubber feet supplied with the Memory Expansion Card using Figure A as a placement guide.

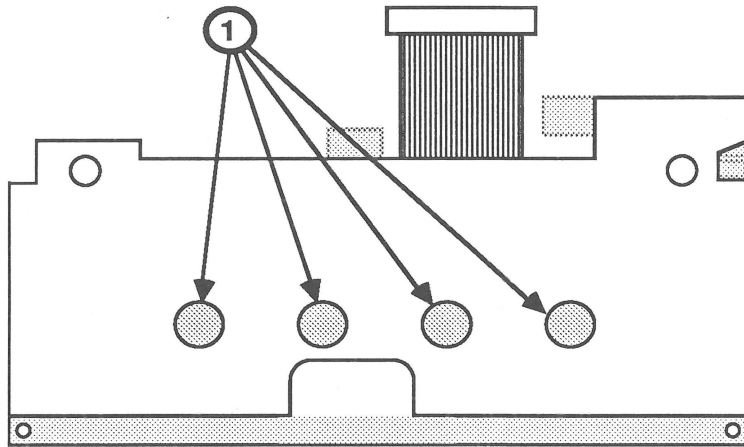

FIGURE A

6. Place the Memory Expansion Card on the four nylon standoffs, component side down and with the connector on the right side. **Gently** press down on the board starting at the connector side and then at each stand-off on the left side.
7. Replace the keyboard.
8. Run the *Apple II Diagnostic Diskette* to verify the correct operation of the card. (See "Diagnostics and Troubleshooting" later in this procedure.)
9. Replace the top cover.
10. Affix the appropriate memory ID sticker (Table 1) to the IIC case between the <OPEN APPLE> and accent mark keys.

<u>Memory Expansion Card Size</u>	<u>Memory ID Sticker</u>
256K	384K
512K	640K
768K	896K
1024K	1.15MB

Table 1

11. Return the IIC to the customer. Include the *Apple IIC Memory Expansion Card Instruction Manual*, "Tell Apple" and Warranty cards, *Apple II Utilities Guide*, and *ProDOS System Utilities Diskette*. **Do not give the Dealer's Installation Instructions or Packing List to the customer.**

Diagnostics and Troubleshooting

The Apple IIC Memory Expansion Card exchange module is shipped **without** socketed RAM. All socketed RAM must be removed from the card before returning it to Apple.

Materials Required

Known-good Apple IIC and Internal Drive
Known-good RAM chips
Apple IIC Memory Expansion Card
Apple II Diagnostic Diskette

Testing the RAM

1. Install the Apple IIC Memory Card into the memory slot.
2. Start up the *Apple II Diagnostic Diskette*. Select the **Apple IIC Memory Expansion Card Test** and run the test.

Note: The ROM on the logic board is verified before the card is tested. If the ROM on the logic board is bad an alert box will appear telling you to test the logic board ROM before continuing. Refer to Section 3, Diagnostics.

...Continued on next page

3. Two types of failures are possible on the Apple IIc Memory Expansion Card:
 - a) If a RAM chip fails, a numbered location on the board will be indicated on the screen (Figure 3).

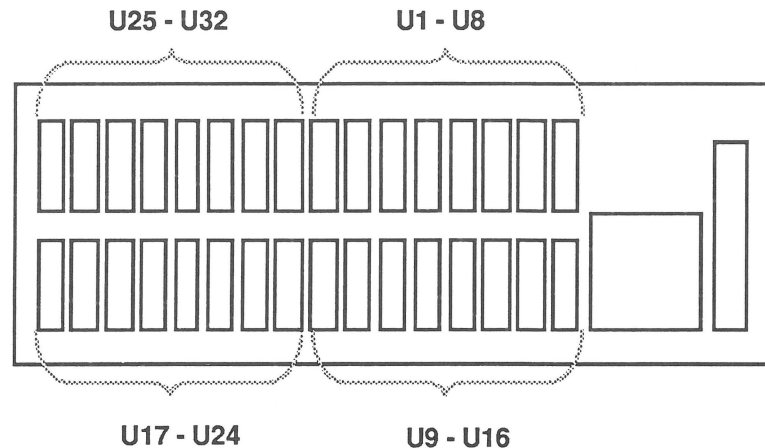

FIGURE 3

- 1) Locate the RAM and replace it with a known-good RAM chip.
 - 2) Retest the card.
 - 3) Repeat steps 1) and 2) until the card passes.
- b) If the problem cannot be corrected by replacing a RAM chip, the screen will tell you to exchange the entire card.
 - 1) Remove all the RAM from the customer's card.
 - 2) Test the module being used for exchange.
 - 3) Install the customer's RAM onto the new module.
 - 4) Run the Apple IIGS Memory Expansion Card Test.
 - 5) Return to the beginning of this step until the card passes.

Logic Board Rubber Feet Installation

1. If the logic board is presently installed in the computer, remove the logic board.
2. Cut a piece of polyester tape about one inch long.

Note: A roll of this tape can be ordered from Apple Service. See your *Service Programs Manual* for ordering information.

3. Place the tape over the metal shield at the location shown in Figure B, #1. It is important that the tape **completely** cover the circular area of the shield.
4. Place the three rubber feet at the locations shown in Figure B, #2.

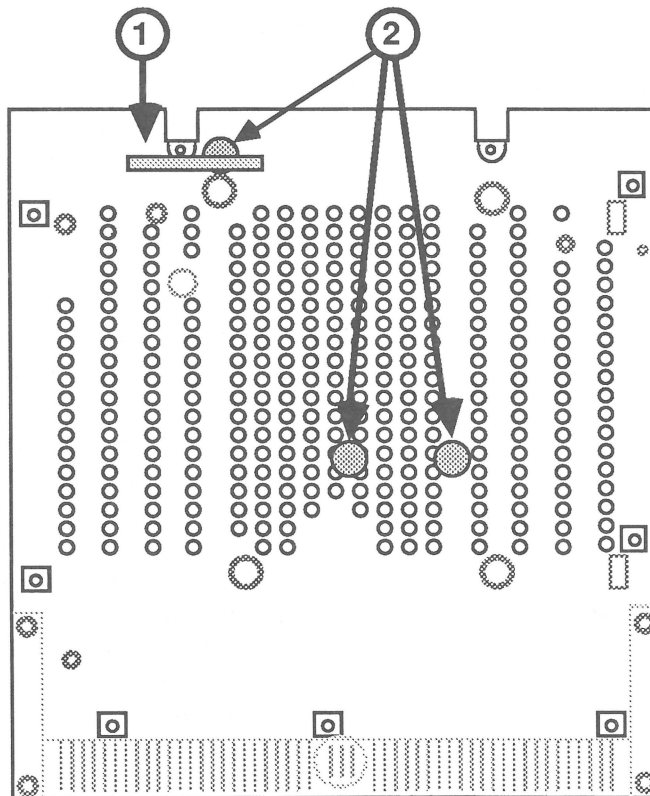

FIGURE B

□ APPLE IIc – MODEL A2S4000

UniDisk 3.5 Compatibility

To utilize a UniDisk 3.5 with an Apple IIc, a new monitor ROM is required. All new Apple IIc's (model A2S4100) have the ROM included. Apple IIc's, model A2S4000, with a serial number greater than F6051GFA, also contain the new monitor ROM.

Customers with a UniDisk 3.5 who purchased an Apple IIc system with a serial number less than F6051GFA will need a ROM upgrade. Exchange the customer's logic board with an upgraded board free of charge. Refer to "Apple IIc Product Notices" in your *Apple Service Programs* manual for additional information.

Serial Port Upgrade

If a customer has problems with devices connected to either of the Apple IIc serial ports, here's what to do:

1. Connect the serial device (printer or modem) to either a known-good Apple IIc or an Apple IIe with a Super Serial Card.
2. Try to transmit to the serial device.

If the device works, swap the logic board of the Apple IIc in question. Refer to your *Apple Service Programs* manual for exchange information.

If the device does not work with the known-good IIc or IIe, the device, cabling, or configuration is faulty.

AC Power Pack Upgrade

If you encounter a flashing screen or wavy lines on a Monitor IIc, check the date code on the AC power pack. The date code is printed in black on the bottom of the AC power pack. The first two digits in the date code indicate the week and the last two digits indicate the year of manufacture.

If the date code is earlier than **45 84**, replace the AC power pack. Check the Price Pages in the *Apple Service Programs* manual for the current price of the AC power pack.

Internal Power Supply Shield Retrofit

If the Apple IIc internal disk drive repeatedly has difficulty reading or writing a diskette, it might be because the IIc internal power supply is not properly shielded. Refer to Figure 4 to determine whether your power supply is shielded.

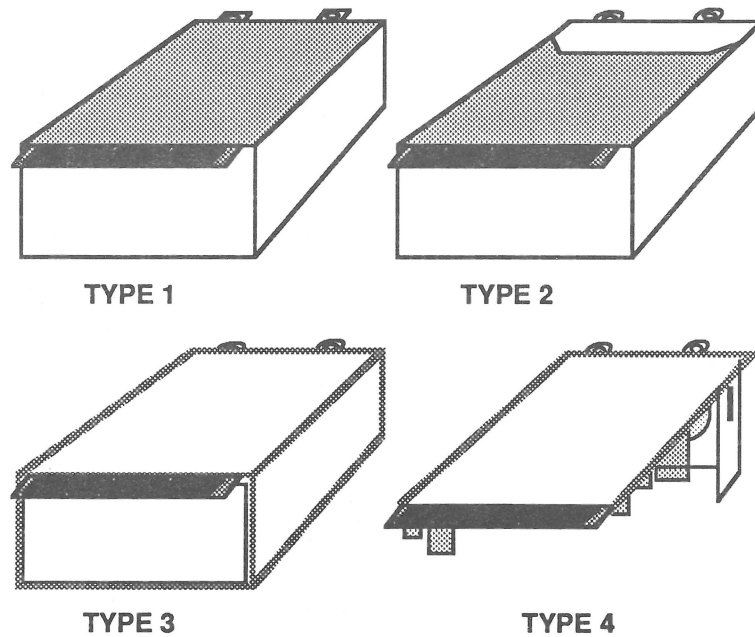

FIGURE 4

The power supply labeled *Type 1*, with the PC board totally exposed, is not shielded. *Type 2* is adequately shielded by the metal bracket across the back of the PC board. *Type 3* is shielded by being fully enclosed. *Type 4*, though completely open, is adequately shielded.

If you have a *Type 1* power supply, use the shield from the power supply in your IIc spares kit and order a new shield. If the drive continues to have reading/writing difficulty, the problem could be the disk drive.

Adding the Power Supply Shield

1. Remove the top cover.
2. Remove the internal power supply.
3. Turn the power supply so that the soldered side of the circuit board is facing up.
4. Slide the shield, hole side first, over the connector end of the power supply. When the shield is in position, you will be able to see **only** the circuit board, and no soldered areas, through the holes.
5. Replace the power supply.

After you put the shield on the customer's power supply, rerun the latest disk drive diagnostic to see if the problem has been fixed. If it has, replace the cover of the IIc.

If the problem has not been fixed, swap the disk drive. Rerun the disk drive diagnostic to verify that the problem has been fixed.

If the problem remains, replace the customer's power supply (without the shield) and disk drive, and send the unit to Apple.

Upper Head Shield Plate Installation

If the IIc repeatedly fails to boot or has difficulty reading or writing, the cause of the problem may be an unshielded disk drive read/write head assembly. To determine if the drive is shielded, lift the head load arm (Figure 5, #1), and compare it with Figures 6 and 7. Figure 6, with the metal plate installed on the head load arm, is completely shielded. Figure 7, without the metal plate installed, is unshielded.

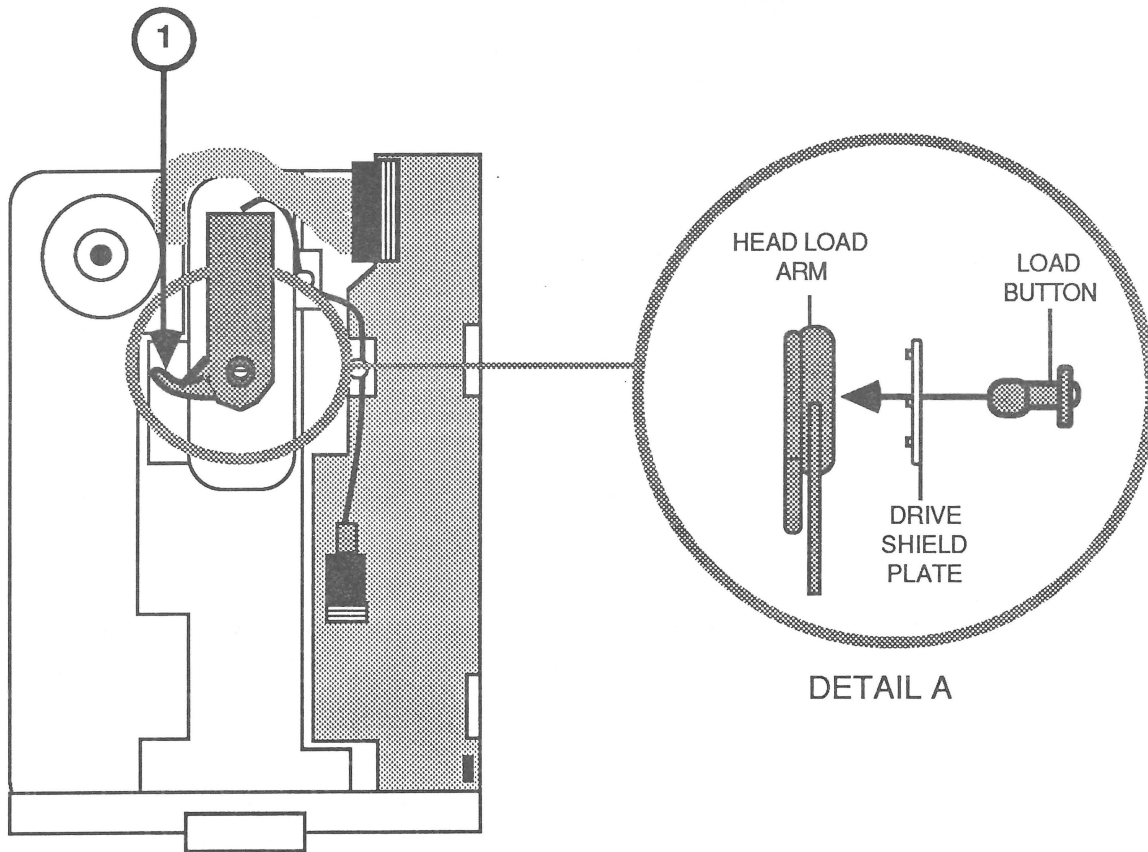

FIGURE 5

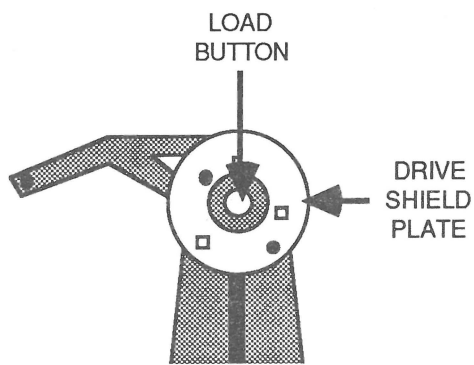

FIGURE 6

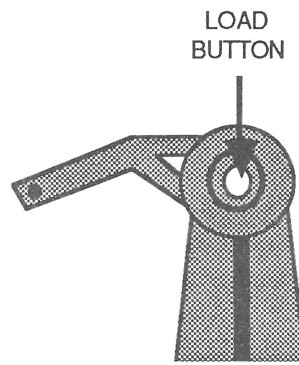

FIGURE 7

If your disk drive looks like Figure 7, install the upper head shield plate. If booting or read/write failures persist, replace the disk drive.

During this procedure, check the head load button for contamination and wear. If the button is worn or dirty, replace it.

Installation

1. Remove the top cover.
2. Remove the disk drive.
3. Remove the four screws, two from either side of the disk drive shield.
4. Pull up on the shield to remove it.
5. Lift up the head load arm, squeeze the top part of the load button with small needlenose pliers, and let the button drop down.
6. Place the upper head shield plate against the head load arm. The raised ridges should face the arm, and the circular opening should line up with the opening in the arm (Figure 8).
7. Reinstall the button (or install a new one if necessary). Insert it through the hole in the shield plate and into the head load arm (Figure 9, detail A). Press the button until it snaps into place.
8. Replace the disk drive shield, ground clip, and corresponding screws.
9. Replace the disk drive.
10. Replace the top cover.

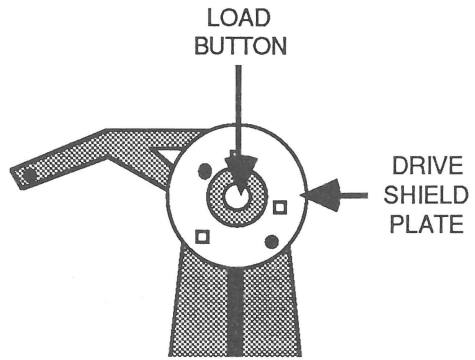

FIGURE 8

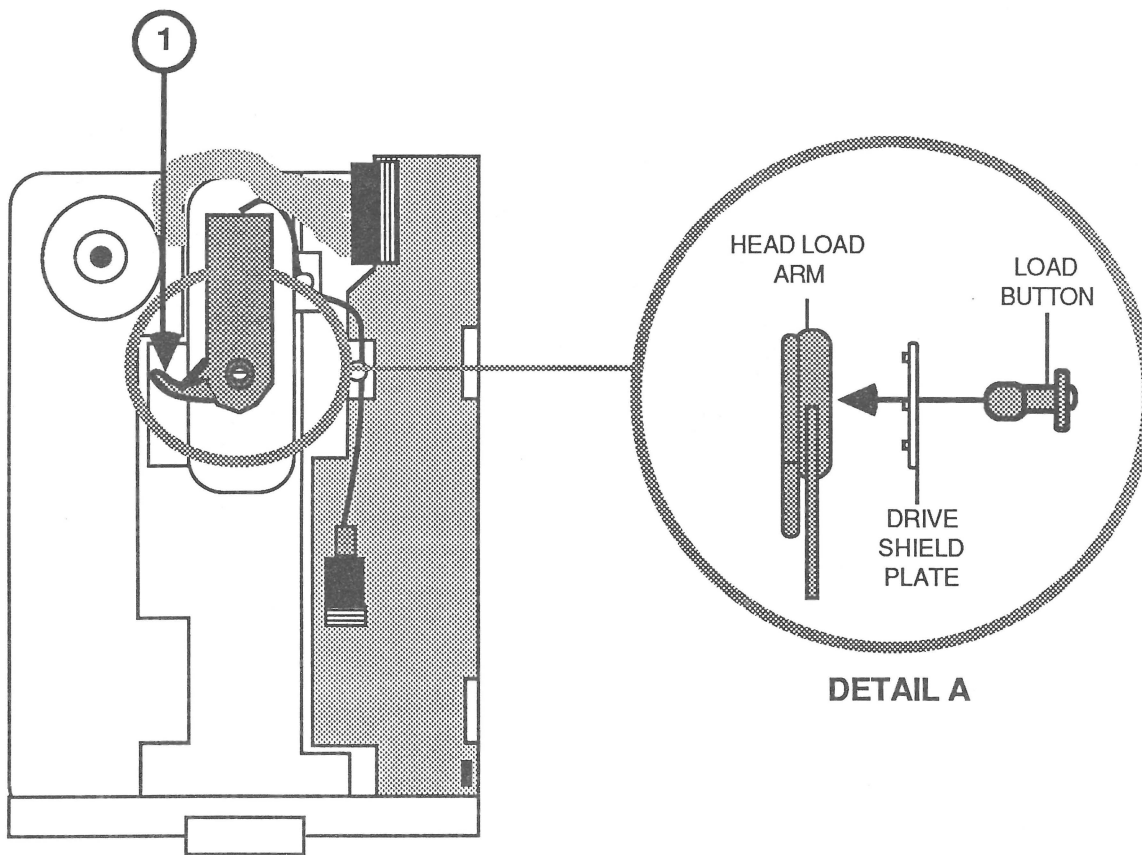

FIGURE 9

Internal Power Supply Upgrade

Check the customer's internal power supply for:

1. The marking "TDK" (Figure 10, #1).
2. A date code between 8501 and 8526 (Figure 10, #2).
These power supplies occasionally turn themselves back on spontaneously. When they do, all RAM on the logic board can be damaged.

Note: Black ink markings in either place indicated in Figure 10, #3, designates a reworked power supply that has had the problem corrected. These power supplies do not need to be exchanged.

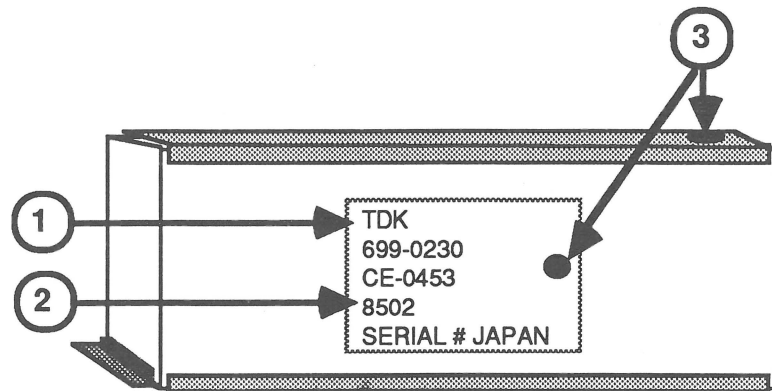

FIGURE 10

If the logic board is bad and the internal power supply meets the above criteria, exchange both modules.

If the logic board is good and the internal power supply meets the above criteria, exchange the internal power supply.

Expandable Logic Board Installation

The Apple IIc Logic Board Upgrade Kit contains an enhanced version of the original IIc logic board. The enhancement, an expansion connector, allows the addition of a Memory Expansion Card (see "Memory Expansion Card Installation" earlier in this section). This card yields a maximum memory configuration of 1.15 megabytes of RAM.

The Expandable Logic Board Upgrade Kit provides customers who own older versions of the Apple IIc with a cost-effective way to gain this memory expansion capability.

Note: This upgrade will also permit the use of a UniDisk 3.5 with the Apple IIc.

Return Information

The old IIc logic board **must** be returned in the Apple-approved packaging for credit. The shipping instructions must be followed **exactly** as stated on the *Apple IIc Logic Board Upgrade Kit Product Return* form.

The logic board **must** be placed in an anti-static bag. Failure to do so could lead to ESD (electrostatic discharge) damage to the board.

Installation

1. Turn off the power to the IIc, and disconnect the power cord and any attached peripherals.
2. Remove the logic board.
3. Install the new Apple IIc logic board.

Note: Some Apple IIc bottom cases contain an additional set of standoffs located underneath the internal power supply. If the IIc you are upgrading contains these standoffs, use a pair of diagonal cutters to cut them off **before** attempting to install the new logic board. (Do not confuse these extra standoffs with the two standoffs that the internal power supply is attached to.)

4. Replace the internal power supply.
5. Replace the disk drive.

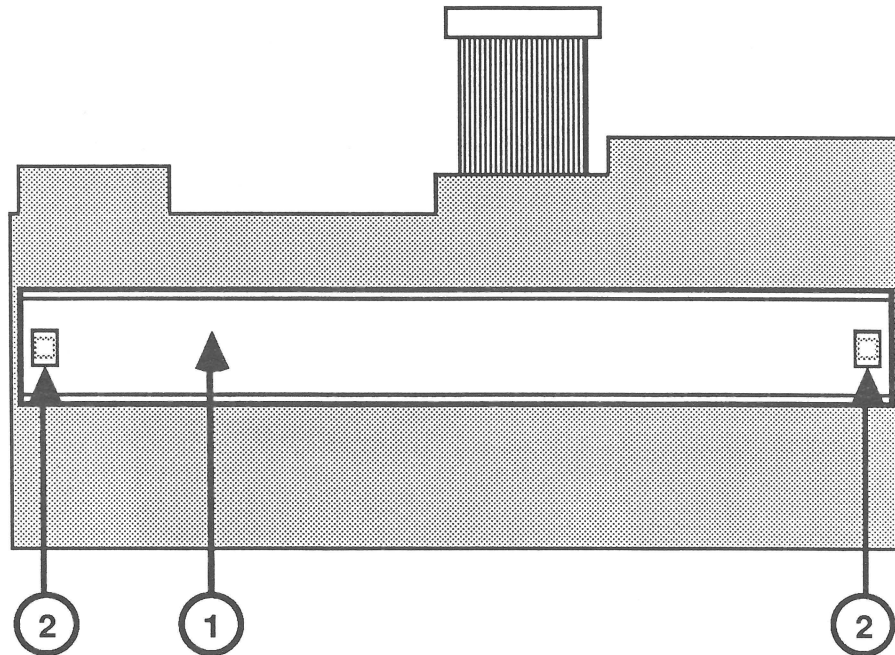

FIGURE 11

6. Some IIc keyboards have a plastic brace attached to the bottom (Figure 11, #1). Before reinstalling the keyboard, check to see if this brace is present. If it is, perform steps 6a through c, to replace the brace. If there is no brace, proceed to step 7.
 - a) Using a pair of needlenose pliers, squeeze the nylon mounting button holding the brace to the keyboard. At the same time, pull the brace away from the keyboard (Figure 11, #2). Repeat for the other mounting button, and remove the brace.
 - b) Insert the small end of the new mounting button through the hole at each end of the new brace.
 - c) Place the new brace on the back of the keyboard. Align the holes in the brace with the two mounting buttons. Press down on the brace until it clicks into place.
7. Replace the keyboard.
8. Plug the power cord into the power socket.

9. Run the *Apple II Dealer Diagnostics*, Part Number 077-0232, to make sure the computer operates correctly.

Note: Earlier versions of Dealer Diagnostics will not operate correctly on the enhanced IIc logic board and therefore will not test correctly.

10. Install the new FCC label on the bottom side of the IIc case. The label should cover the present label or engraving (Figure 12).

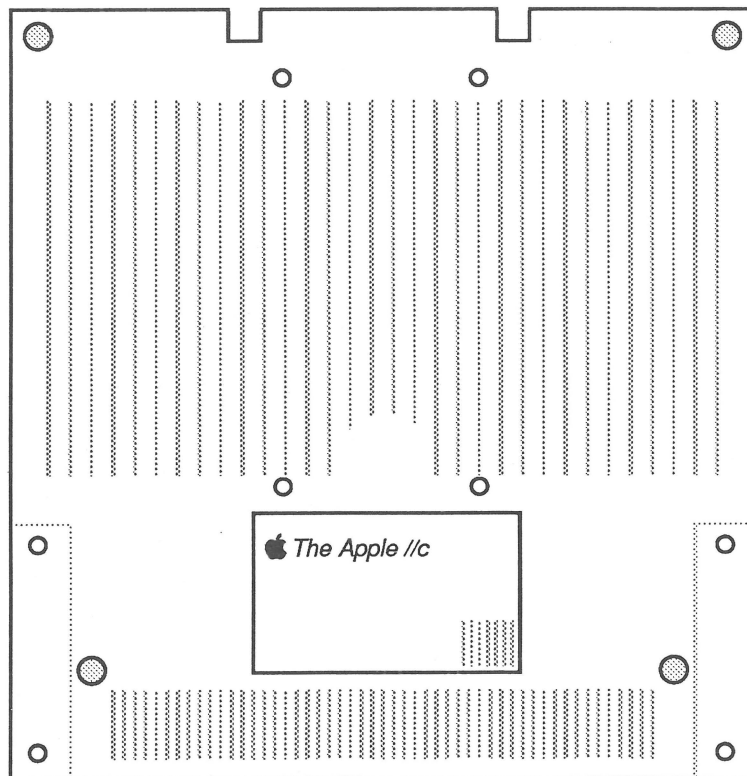

FIGURE 12

11. If you are installing a Memory Expansion Card, see the installation instructions earlier in this section, before you proceed to step 12.

12. Replace the top cover.
13. Return the IIC to the customer. Include the *New Features Update* and the Warranty card. **Do not give the dealer's installation instructions or packing list to the customer.**

Expandable Logic Board ROM Upgrade

There is a ROM upgrade available that corrects a minor bug when using terminal mode.

The old ROM is P/N 342-0445-A; the new replacement ROM is P/N 342-0445-B.

Materials Required

ESD equipment
IC extractor
ROM P/N 342-0445-B

Procedure

1. Set up the ESD equipment (refer to the *You Oughta Know Technical Procedures*).
2. Remove the top cover.

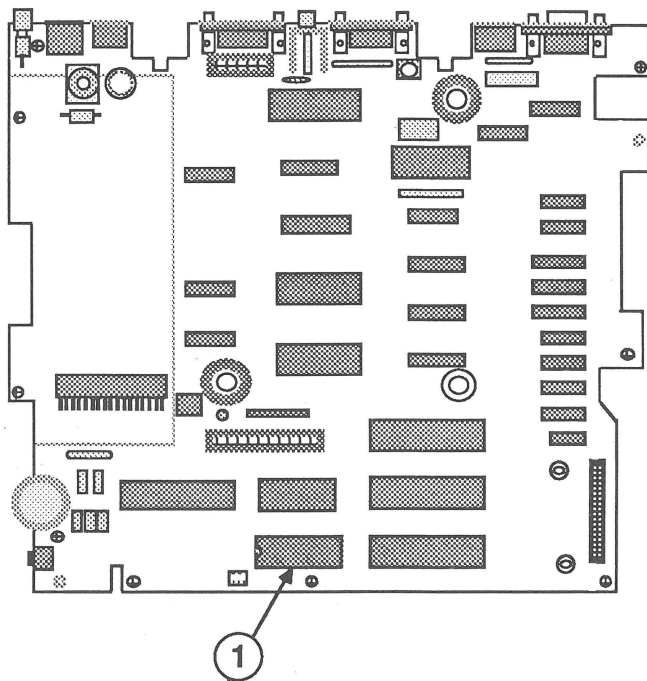

FIGURE 13

3. Remove the Memory Expansion Card, if present.
4. Locate the ROM at location D19 (Figure 13, #1) and verify that it is the old ROM (P/N 342-0445-A).
5. Using an IC extractor, remove the old ROM installed at location D19 (Figure 13, #1).
6. Install the new ROM in the same location, D19 (Figure 13, #1). There is a notch at one end of the ROM. This notch should line up with the white dot on the logic board.
7. Replace the Memory Expansion Card, if it was present.
8. Replace the top cover.
9. Run the diagnostics to verify that the machine is functioning correctly.

Apple IIc

Section 7 – Adjustments

□ CONTENTS

7.2 DSPEED

Note: If a step is underlined, detailed instructions for that step can be found in Section 2, Take-Apart.

□ DSPEED

This adjustment procedure was written to be used with the *Apple 5.25-Inch Disk Drive Diagnostic*—if the test indicates that you need to adjust the drive speed. All information on setting up and running the diagnostic is in the *Disk Drives Technical Procedures*, Section 1, 5.25-Inch Drive Diagnostic.

Materials Required

Apple 5.25-Inch Disk Drive Diagnostic diskette
Disk Drives Technical Procedures
Small (jeweler's) flatblade screwdriver
Apple IIc with video display

Making the Adjustment

To adjust the DSPEED (drive motor speed):

1. Start the DSPEED diagnostic running (see the *Disk Drives Technical Procedures*, Section 1, 5.25-Inch Drive Diagnostic).
2. Turn the Apple IIc upside down, and locate the DSPEED adjustment hole in the bottom of the case.

Note: When you make the DSPEED adjustment, keep the disk drive flat.

3. The adjustment is extremely sensitive, so turn the adjustment screw very slowly. The indicator on the screen will move back and forth, showing changes of the speed.
4. Adjust the speed so that the indicator is within the "good" range, as close to 0 as possible. Let the test run for 30 seconds.

5. Press <Escape> to return to the main menu; then repeat the test.

Does the DSPEED now stay within the "good" range?

- Yes—Press <Escape> to return to the main menu.
 - No—If the DSPEED cannot be properly adjusted, return the faulty mechanical assembly to Apple.
6. Remove the *Apple 5.25-Inch Disk Drive Diagnostic* diskette from the external drive.

Apple IIc

Illustrated Parts List

☐ CONTENTS

- IPL.3 Finished Goods Assembly (Figure 1)
- IPL.5 Memory Expansion Card (Figure 2)

The figures and lists in this section include all piece parts that can be purchased separately from Apple for the Apple IIc, along with their part numbers. These are the only parts available from Apple. Refer to your *Apple Service Programs Manual* for prices.

Note: There are two replacement keyboards for the Apple IIc. When ordering them, you should be aware of the following differences:

- "Keycap Set, Beige" keyboards replace the original IIc keyboards, which rest on top of a black sheet of plastic.
- "Alps" keyboards replace other Alps keyboards, which do **not** rest on a plastic sheet.

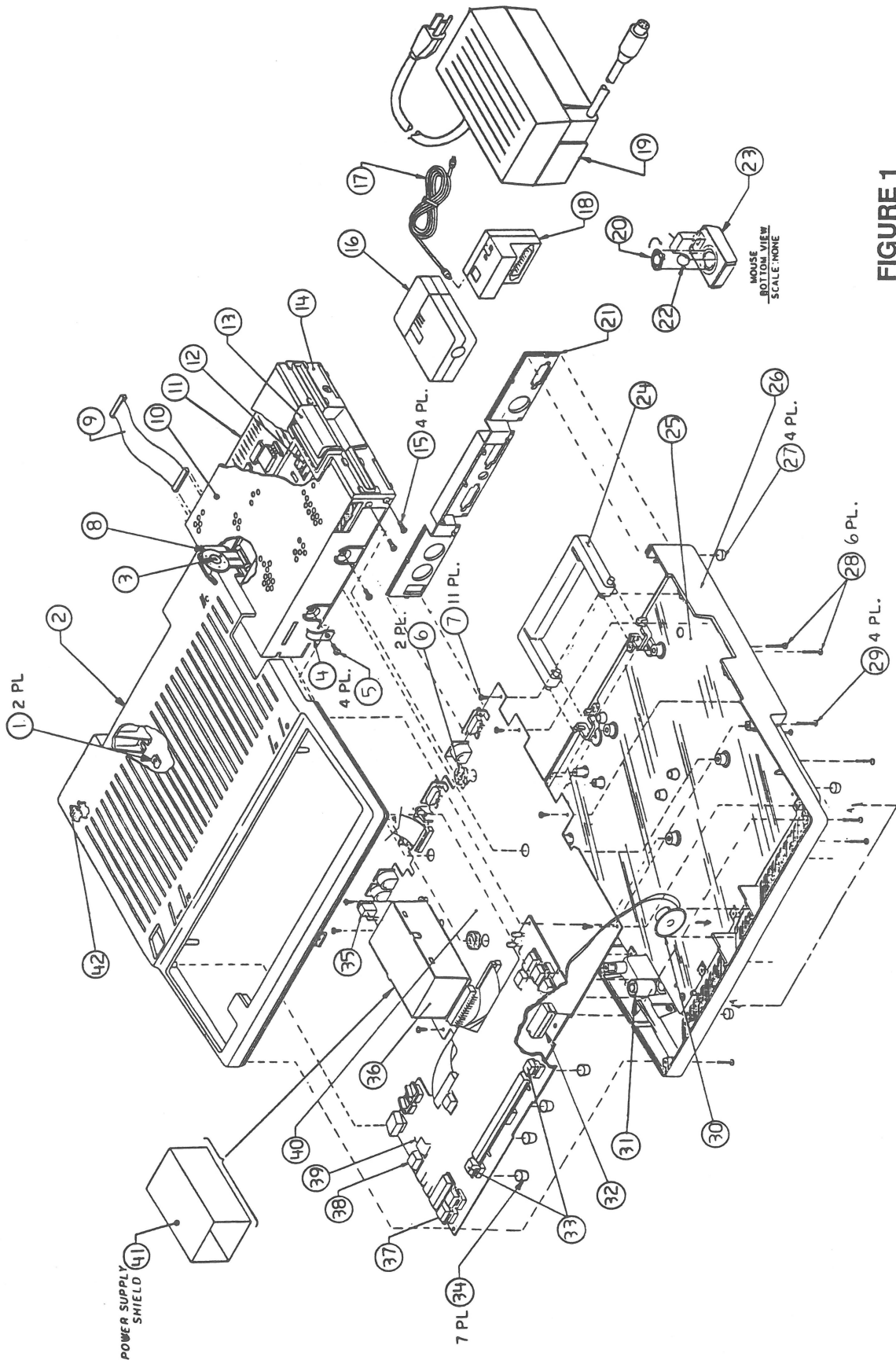

FIGURE 1

□ APPLE IIc - FINISHED GOODS ASSEMBLY (Figure 1)

<u>Item</u>	<u>Part No.</u>	<u>Description</u>
1	835-0174	U Type Nut
2	612-5029	Apple IIc Top Case with Back Panel
3	U815-0664	Load Button
4	805-0877	Ground Clip
5	400-1604	Screw, Disk Drive Shield
6	875-0049	Grounding Washer
7	430-1019	Tap Screw 4-24 x .250
8	805-5038	Upper Head Shield Plate
9	590-0181	Internal Disk Drive Cable
10	661-0264	Apple IIc Drive Mechanical Assembly
11	661-0265	Apple IIc Drive Analog Board
12	870-0023	Spring, Disk Door (Latch)
13	815-0811	Disk Drive Door (Latch), Beige
	815-0587	Disk Drive Door (Latch), Platinum
14	815-0810	Disk Drive Bezel
15	970-0473	Screw, Disk Drive Bezel
16	699-0242	RF Modulator Switch Box
17	699-0228	RF Modulator Cable
18	699-0220	RF Modulator
19	699-0424	AC Power Pack (110v)
20	815-0409	Mouse Ball Retainer
21	815-0813	Back Panel
22	699-8001	Rubber Coated Mouse Ball
23	661-0259	Apple II Mouse, Beige
	661-0400	AppleMouse, Platinum
24	865-0030	Handle, Beige
	865-0027	Handle, Platinum
25	725-0014	Bottom Shield Insulator
26	612-5030	Apple IIc Bottom Case
27	865-0021	Foot
28	400-1612	Screw, 6-32 x 3/4
29	430-1020	Tap Screw, 4-24 x .750, PN CRS Rec. A
30	600-0349	Speaker
31	109-0648	Volume Control Knob
32	342-0445	IC, ROM, Apple IIc Logic Board, Expandable
33	705-0040	Keyswitch, Low Profile (for original IIc keyboard)
	970-1262	Apple IIc Alps Keyswitch
34	865-0003	Rubber Foot
35	705-0041	On/Off Switch
36	661-71182	Apple IIc Power Supply (Internal)
37	705-0102	Keyswitch, Alternate
	970-1263	Alps Keyswitch, Locking
38	658-7055	Keycap Set, Beige (for original IIc keyboard)
	658-7083	Alps Keycap Set, Beige
	658-7096	Alps Keycap Set, Platinum
39	661-0294	Apple IIc Alps Keyboard, Beige
	661-0361	Apple IIc Alps Keyboard, Platinum
40	661-91177	Apple IIc Logic Board
	661-0359	Apple IIc Logic Board, Expandable
41	612-5004	RFI Shield Assembly, Power Supply
42	825-0907	Logo

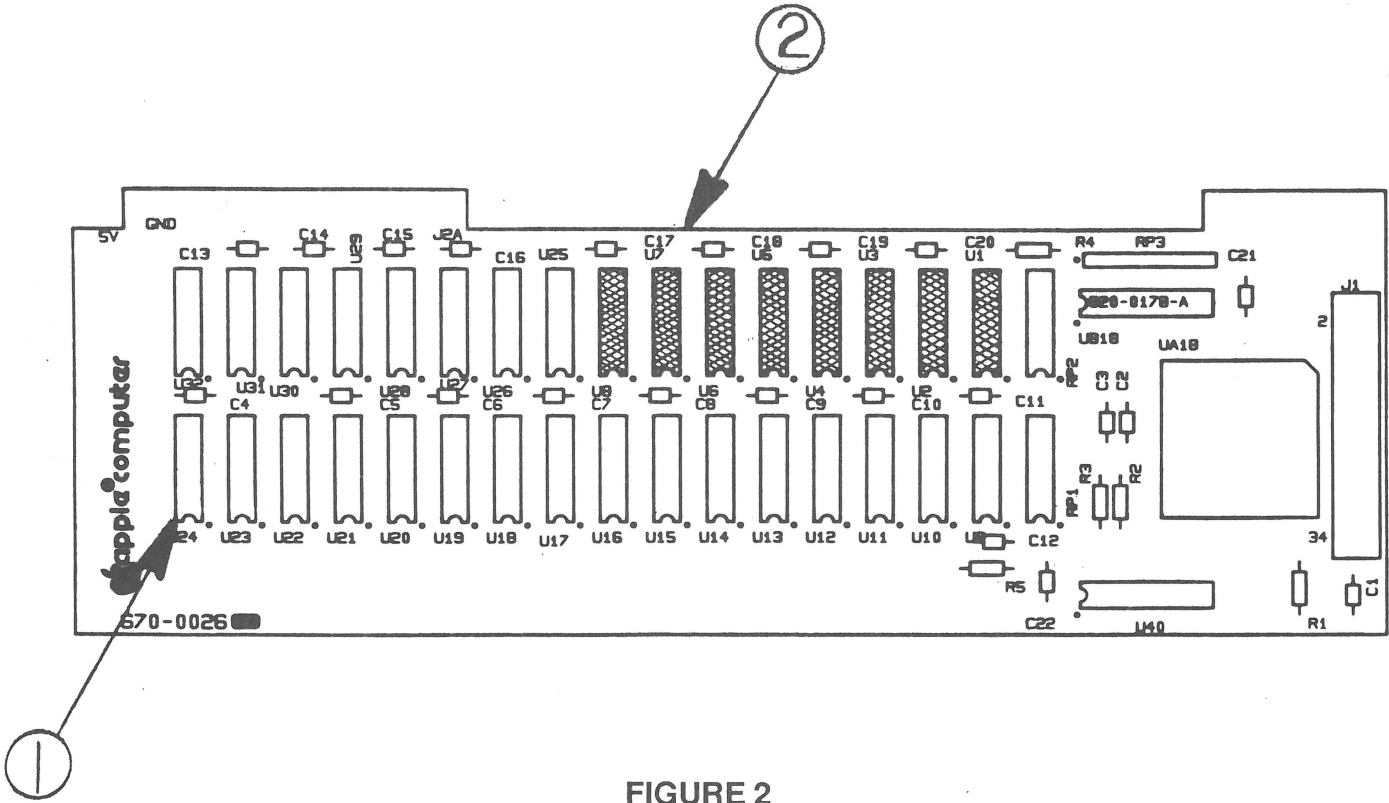

FIGURE 2

□ **APPLE IIc – MEMORY EXPANSION CARD (Figure 2)**

<u>Item</u>	<u>Part No.</u>	<u>Description</u>
1	334-0021	IC, RAM, 256K
2	661-0360	Apple IIc Memory Expansion Card

Note: The eight ICs that are shadowed in Figure 2 are soldered to the Memory Expansion Card. The 24 sockets on the card can be filled with 256K RAM ICs for memory expansion.

Apple IIGs

Technical Procedures

□ TABLE OF CONTENTS

Section 1 – Basics	1.2	Product Description
	1.2	Apple IIGs Features
	1.3	Apple IIGs, 1 MB Features
	1.5	Connector Identification
	1.5	Back Panel
	1.5	Internal Connectors
	1.6	Theory of Operation Overview
	1.6	Introduction
	1.6	Apple IIGs and IIGS, 1 MB Logic Board
	1.9	Power Supply
	1.9	Apple Desktop Bus Keyboard and Mouse
Section 2 – Take-Apart	2.3	Electrostatic Discharge Prevention
	2.3	What Is ESD?
	2.3	Rules to Follow
	2.5	Top Cover
	2.7	Power Supply
	2.9	Case Hinge
	2.11	Main Logic Board
	2.13	Apple Desktop Bus Keyboard
Section 3 – Diagnostics	3.2	Introduction
	3.2	General Information
	3.2	Before You Start
	3.2	Built-In Diagnostics
	3.3	Things to Remember
	3.5	Apple II Diagnostic Disk
	3.5	Materials Required
	3.5	Main Menu Selections
	3.6	Choose Tests
	3.9	Options
	3.10	Special
3.11	Running the Diagnostics	
3.14	Running the Memory Card Tests	
3.16	Test Failures	

**Section 4 –
Troubleshooting**

- 4.2 Introduction
- 4.2 General Information
- 4.2 Before You Start
- 4.2 How to Use the Symptom Chart
- 4.3 Things to Remember
- 4.5 Apple IIGS Symptom Chart
- 4.5 System Problems
- 4.5 Video Problems
- 4.6 Drive Problems
- 4.6 Peripheral Problems
- 4.7 Miscellaneous Problems

**Section 5 –
Additional
Procedures**

- 5.2 Apple IIGS Fan Kit
- 5.2 ProFile Interface Card Modification
- 5.4 Apple IIGS Memory Expansion Card
- 5.4 Introduction
- 5.6 Troubleshooting
- 5.6 ROM and Video Graphics Controller Upgrades
- 5.6 Introduction
- 5.6 ROM Upgrade
- 5.8 VGC Upgrade
- 5.10 Keyswitches
- 5.11 Battery Verification
- 5.11 Introduction
- 5.11 Verification Procedure
- 5.13 Battery Replacement
- 5.13 Introduction
- 5.14 Apple IIGS
- 5.16 Apple IIGS, 1 MB
- 5.18 Shield Tabs
- 5.18 Apple IIGS
- 5.19 Apple IIGS, 1 MB

**Section 6 –
Upgrade for
Apple IIe**

- 6.2 Apple IIGS Upgrade for the Apple IIe
- 6.2 Introduction
- 6.2 Things to Remember
- 6.3 Materials Required
- 6.3 Installation Instructions
- 6.8 Apple IIe Extended Keyboard Modification

**Illustrated
Parts List**

- IPL.3 Main Assembly (Figure 1)
- IPL.5 Base Assembly (Figure 2)
- IPL.6 Logic Boards
- IPL.7 Keyboard (Figure 3)
- IPL.9 Mouse (Figure 4)
- IPL.11 Cables (Figure 5)
- IPL.13 Upgrade (Figure 6)

©Apple Computer, Inc., 1986 - 1990. No portion of this document may be reproduced in any form without the written permission of Apple Computer, Inc.

Apple Desktop Bus is a trademark of Apple Computer, Inc.

Apple IIGs, AppleTalk, UniDisk, Apple, and the Apple logo are registered trademarks of Apple Computer, Inc.

Apple IIgs

Section 1 – Basics

□ CONTENTS

1.2	Product Description
1.2	Apple IIgs Features
1.3	Apple IIgs, 1 MB Features
1.5	Connector Identification
1.5	Back Panel
1.5	Internal Connectors
1.6	Theory of Operation Overview
1.6	Introduction
1.6	Apple IIgs and IIgs, 1 MB Logic Board
1.9	Power Supply
1.9	Apple Desktop Keyboard and Mouse

□ PRODUCT DESCRIPTION

Apple IIGS Features

The Apple IIGS incorporates many features of the Apple IIe and the Apple IIc, making it possible to run many of the existing programs. The Apple IIGS supports the same peripherals as the Apple IIe.

The Apple IIGS includes these new or improved features (as compared to the Apple IIe or Apple IIc):

- A 16-bit, 65C816 microprocessor. The 65C816 can run at 2.8 MHz or at 1 MHz (selectable by the user or the application).
- A minimum memory configuration of 256K.
- The Apple Desktop Bus™, a simple I/O port that supports the detached keyboard and built-in mouse interface. This provides an inexpensive way to connect additional input devices.
- A built-in real-time clock, powered by a long-life battery.
- Built-in RGB and NTSC (composite) video outputs.
- The standard video modes include colored text (RGB only) and colored borders.
- Two super-high-resolution graphics display modes. Double Hi-Res is 320 x 200 pixels with sixteen colors. Super Hi-Res is 640 x 200 pixels with four colors.
- New sound-generating abilities from a special-purpose sound synthesizer IC that has fifteen independent voices.
- A built-in AppleTalk® interface.

Apple IIGS, 1 MB Features

The Apple IIGS, 1 MB is the next generation in the Apple IIGS line. The system is designed to provide faster boot time, greater memory, and more built-in ROM-based tools.

The Apple IIGS, 1 MB includes these new or improved features (as compared to the Apple IIGS):

- A minimum memory configuration of 1 MB
- Two 128K ROMs for a total of 256K, double the ROM space
- A new keyboard microcontroller
- A new and improved FPI chip called the CYA, (Control Your Apple)
- A built-in real-time clock, powered by a long-life battery in a battery holder for ease of replacement
- Built-in RGB and NTSC (composite) video outputs
- Improved built-in ROM-based sound-generating abilities
- AppleTalk availability on slots 1 and 2
- Faster 800K drive support

Control Panel

The Control Panel is a resident utility program that can be accessed from the keyboard. The operating speed, video display modes, I/O port assignments, and slot allocations can all be changed from this utility.

The Apple IIGS, 1 MB has a molex connector at location C7. If a jumper **is installed** on the connector, access to the Control Panel is denied. If a jumper **is not installed**, access to the Control Panel is available.

□ CONNECTOR IDENTIFICATION

Back Panel

The back panel of the Apple IIGS and IIGS, 1 MB logic board has eight ports, which are listed below. The number beside the port name corresponds to the numbered arrow in Figure 1 for the IIGS and in Figure 2 for the IIGS, 1 MB logic board.

- 1) Apple Desktop Bus
- 2) Composite video
- 3) RGB video
- 4) Disk I/O
- 5) Game I/O
- 6) Serial 1
- 7) Serial 2
- 8) Earphone

Internal Connectors

There are seven connectors on the Apple IIGS logic board and five connectors on the IIGS, 1 MB logic board. Some of these connectors can only be found on an Apple Service exchange module or a retrofit board. The letter beside the connector name corresponds to the lettered arrow in Figure 1 for the IIGS and in Figure 2 for the IIGS, 1 MB logic board.

- A) Power connector for the Apple IIe (retrofit only)
- B) Power connector for the Apple IIGS system
- C) Fan connector (additional kit)
- D) Numeric keypad connector for the Apple IIe keypad (retrofit only)
- E) Game I/O connector
- F) Keyboard connector for the Apple IIe (retrofit only)
- G) Speaker connector
- H) Control panel bypass

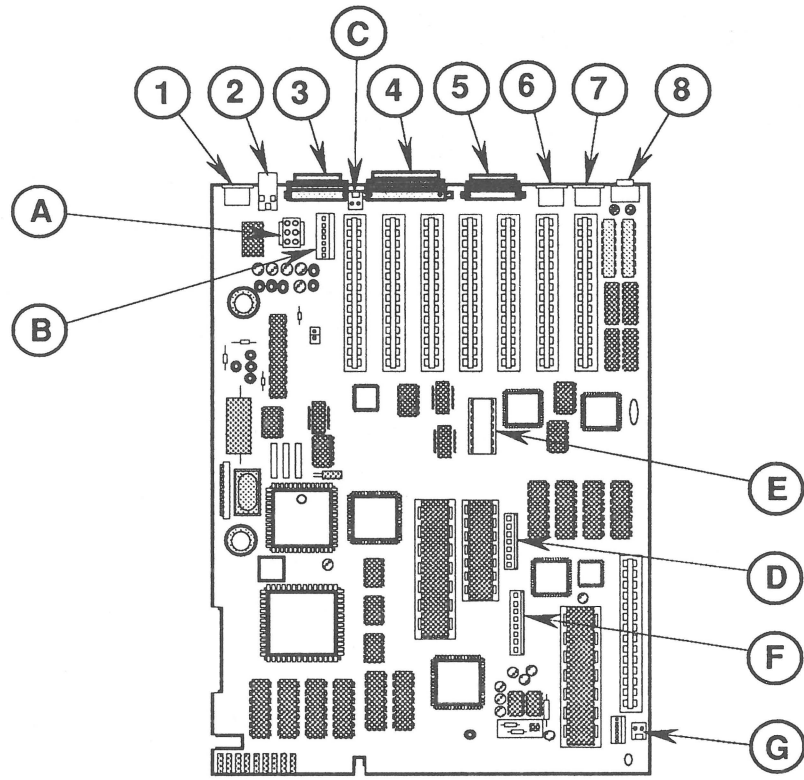

FIGURE 1

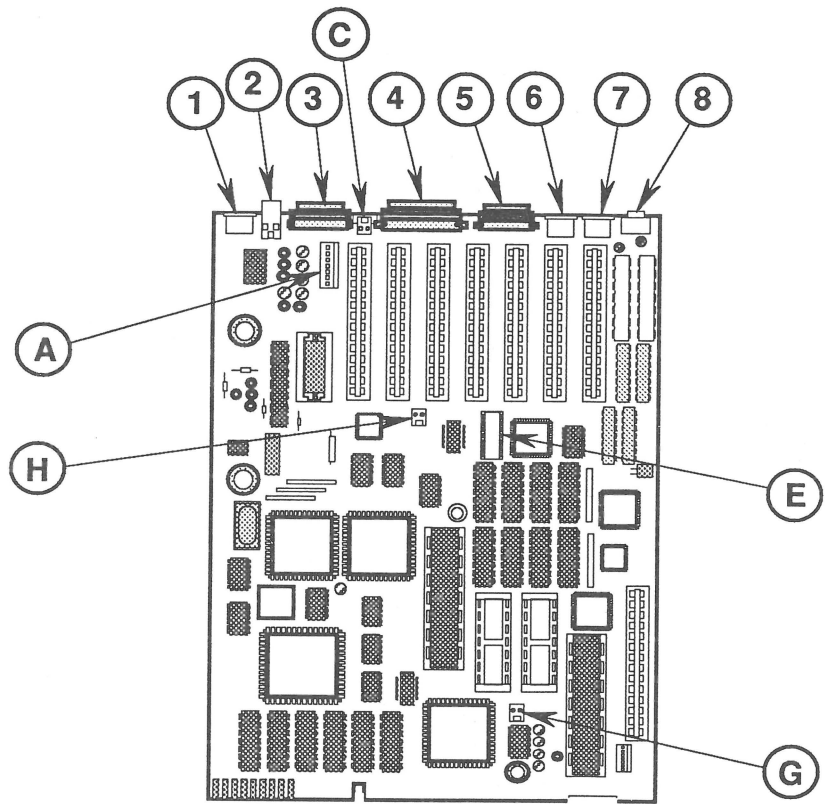

FIGURE 2

□ THEORY OF OPERATION OVERVIEW

Introduction

The Apple IIGs and IIGs, 1 MB is made up of three basic modules: the logic board, the power supply, and the Apple Desktop Bus Keyboard. This section will give you the necessary information to perform logical troubleshooting on the Apple IIGs. The information here includes a description of each module and the various functions it performs.

Apple IIGs and IIGs, 1 MB Logic Board

The logic board is the heart of the system. The CPU is the 65C816, a 16-bit CMOS microprocessor that is compatible with the 6502 and 65C02.

The Apple IIGs logic board is divided into two subsystems: the Mega II IC provides support for existing Apple II software; the Fast Processor Interface IC (FPI) provides the new functions for the Apple II family.

The Apple IIGs, 1 MB logic board is divided into two subsystems: the Mega II IC provides support for existing Apple II software; the Control Your Apple (CYA) ASIC provides additional functions for the Apple II family.

Mega II IC

The Mega II is a custom IC and is found on both the Apple IIGs and the Apple IIGs, 1 MB logic boards. It performs the functions of the following IIG components:

- MMU (Memory Management Unit) Custom IC
- IOU (Input/Output Unit) Custom IC
- Character Generator ROMs (8 languages)
- TMG (Timing Management Generator) IC
- GLU (General Logic Unit) IC

In addition, it provides:

- Support of additional RAM
- Video logic

The Mega II IC is a full-function Apple II, providing the traditional support of slots as well as the support of the built-in ports.

*Fast
Processor
Interface IC*

The FPI is only on the Apple IIGS and provides the following:

- Support of additional RAM
- I/O "shadowing" on page 1 (This allows I/O reads to be done at full system speed.)

*Control
Your
Apple ASIC*

The CYA is only on the Apple IIGS, 1 MB and provides the following:

- Support of additional RAM and ROM on the fast side
- I/O "shadowing" on page 1 and 2 (This allows I/O reads to be done at full system speed.)

All communication with the outside world has to go through the Mega II IC. The system has to run at 1 MHz to remain compatible with all the existing interface cards and various peripherals.

The fast side of the Apple IIGS or IIGS, 1 MB is controlled by either the FPI or CYA, respectively. Both of these ICs are the processor and memory controller for the fast side. The term *fast side* will be used generically to explain how the machine operates.

During normal operation, the fast side of the system runs at 2.8 MHz and the Mega II side at 1 MHz. However, when it is necessary for the CPU to access an I/O port or a RAM location on the Mega II side of the system, the system is briefly slowed to 1 MHz and synchronized with the Mega II timing so that the access can be accomplished. When the access is complete, the fast side returns to the normal 2.8 MHz operating speed, and the Mega II continues at 1 MHz.

*FPI and CYA
Differences*

The following chart summarizes the differences in the FPI and CYA RAM and ROM built-in capabilities

Feature	FPI	CYA
Memory—Mega II side	128K	128K
Memory—fast side	128K	1 MB
Total memory	256K	1.128 MB
ROM	One 1 Megabit	Two 1 Megabit
ToolBox routines	RAM-based	ROM-based

*Video
Graphics
Controller*

The Video Graphics Controller (VGC) is a custom IC that provides

- Improved support of existing Apple II video
- New video display with borders
- New video modes
- An interface to the real-time clock chip
- Interrupt handling

Slotmaker

The Slotmaker is a custom IC that generates control signals for the Apple II family I/O bus. The Slotmaker decides which of more than two dozen select lines to enable by the information it receives from the Mega II.

*Keyboard
General
Logic Unit*

The keyboard General Logic Unit (GLU) works in conjunction with the keyboard microcontroller to form an intelligent input device interface.

*Sound
General
Logic Unit*

The sound General Logic Unit (GLU) serves as an interface between the sound chip, the reserved 64K by 8 dynamic RAM (used by the sound chip), and the Apple IIGS system.

*Apple
Desktop
Bus*

The Apple Desktop Bus is a method and protocol for connecting input devices with computers. The Apple IIGS controls the flow of data to all connected devices by issuing various commands through the Apple Desktop Bus. All devices connect with the Apple IIGS via a 3-wire shared bus that uses 4-pin mini DIN jacks at each device. A total of 16 devices can be connected to the bus.

*IWM
Disk
Controller*

The Apple IIGS uses 3.5-inch micro-floppy disk drives that utilize the Group Code Recording (GCR) disk format. The IWM, a self-contained disk controller card on one IC, simplifies the microprocessor's task of reading and writing data to and from the disk drives.

*Memory
Expansion
Slot*

The memory expansion slot allows you to add a memory card holding up to 4 megabytes of RAM or 896K of ROM memory. This slot supports memory only.

**Power
Supply**

The power supply operates on standard line voltage and outputs various DC voltages, which are used by the logic board and by some peripheral devices (such as UniDisk™ and UniDisk 3.5).

**Apple Desktop Bus
Keyboard and
Mouse**

The keyboard connects to the Apple Desktop Bus port on the rear of the Apple IIGS. The keyboard has its own microprocessor, which is called the keyboard microcontroller.

All devices that are made for the Apple Desktop Bus have some kind of microprocessor that makes them intelligent devices. All except the mouse have ports for connecting other devices. The mouse must be the last device attached to the Apple Desktop Bus because the mouse has no port for connecting additional devices.

Apple IIGs

Section 2 – Take-Apart

□ CONTENTS

- 2.3 Electrostatic Discharge Prevention
 - 2.3 What is ESD?
 - 2.3 Rules to Follow
- 2.5 Top Cover
- 2.7 Power Supply
- 2.9 Case Hinge
- 2.11 Main Logic Board
- 2.13 Apple DeskTop Bus Keyboard

Note: The underlined steps in the following section refers to the take-apart for that particular module.

WARNING: *Be sure the power has been disconnected before attempting any of these procedures.*

□ ELECTROSTATIC DISCHARGE PREVENTION

What Is ESD?

ESD (Electrostatic Discharge) can cause severe damage to sensitive micro-circuits. Just touching a chip or brushing it with a nylon sleeve can degrade a circuit so that it never performs again to specifications. Some microcircuits are sensitive to as little as 500 volts, or about one-sixth as much static electricity as you can feel.

Rules To Follow

Certain preventive measures must be taken to avoid ESD damage. When you are unwrapping, installing, or replacing any microcircuits, observe the following precautions:

- **Before handling boards or ROMs, ground yourself!** Wear a grounding wriststrap and attach it to your workbench pad. The pad must then be grounded to a workbench that is grounded to the building's ground.
- **Ground the chassis to the same potential you hold.** Place the unplugged Apple IIGS chassis assembly on the grounded workbench pad and connect the chassis to the workbench pad via an alligator clip.
- **Use antistatic bags for carrying boards and ROMs.** Whenever ROMs or boards are to be stored or moved anywhere, first put them in antistatic bags. Be sure to touch the bags before touching the ROMs or boards.
- **Handle ROMs by the body, not the leads.** You may safely touch the leads only if you are grounded.
- **Do not wear polyester clothing or bring plastic, vinyl, or styrofoam into the area.** The static field around these materials cannot be removed.
- **Do not place board or ROMs on any metal.** Place them on the grounded workbench pad or on antistatic or nonconductive foam.

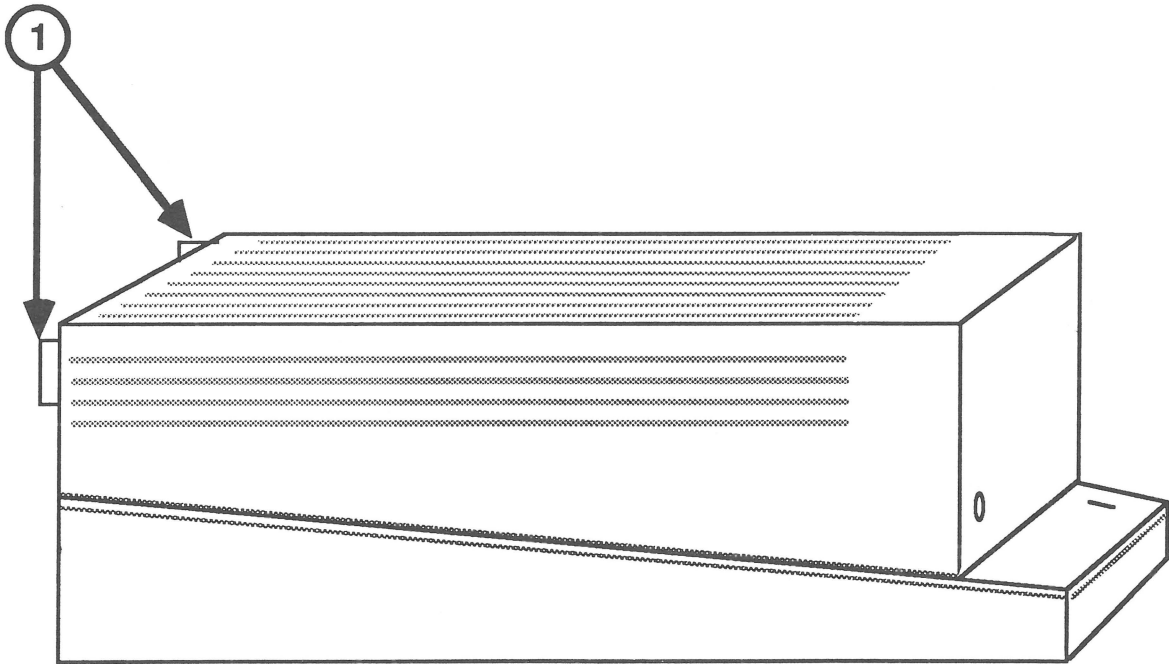

FIGURE 1

□ TOP COVER

Materials Required (None)

Remove

1. Disconnect the keyboard.
2. Place the machine with the front facing you.
3. Locate the tabs on the back of the machine (Figure 1, #1), one on each side. Push the tabs in with your index fingers and lift the top cover, back first, from the machine. No force is necessary. (Do not push down on the top of the machine with your thumbs.)

Replace

1. Position the top cover, front first. Align the bottom front edge with the plastic tabs on the front of the machine.
2. Lower the top cover until the rear tabs snap into position.
3. Connect the keyboard.

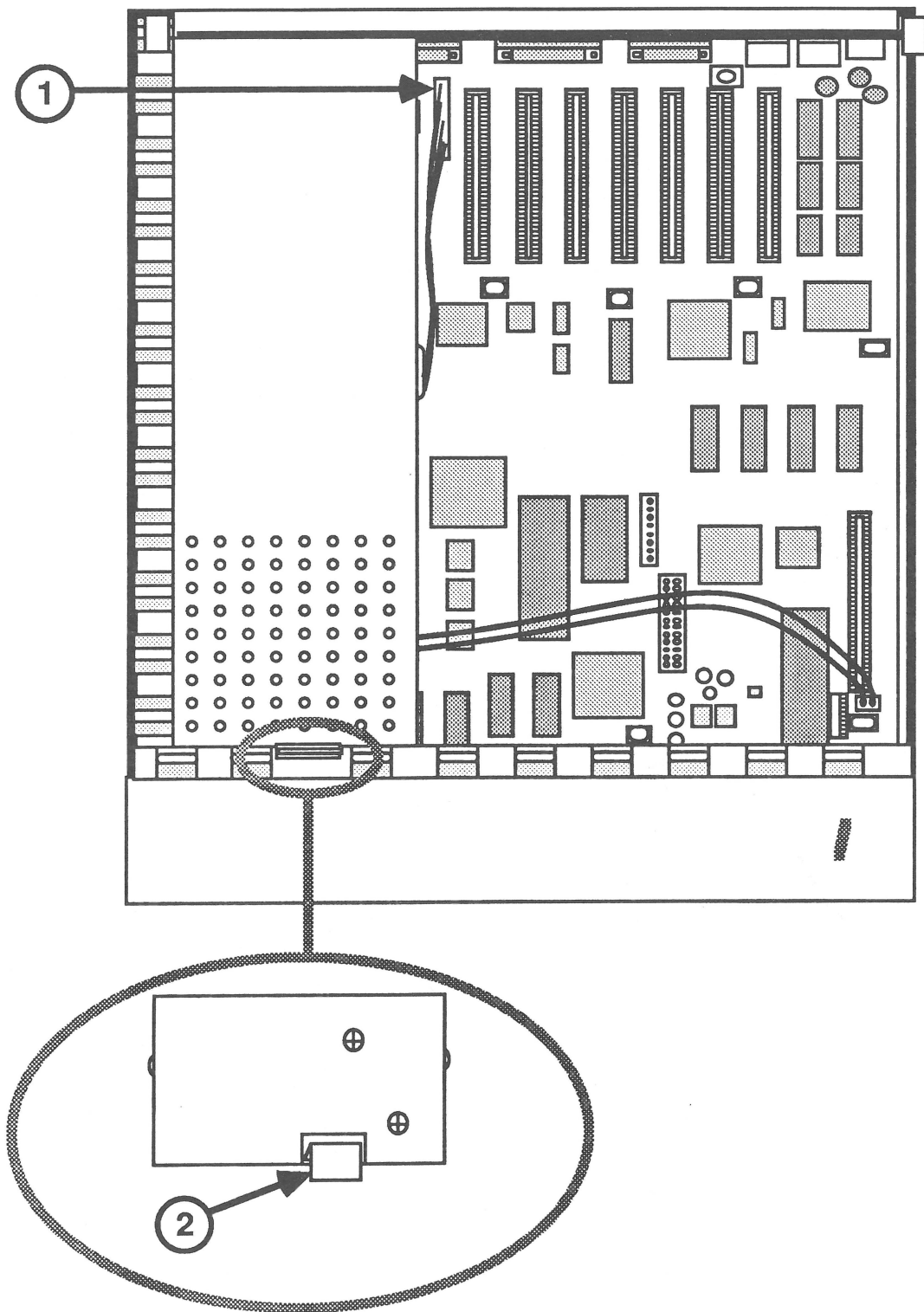

FIGURE 2

□ POWER SUPPLY

Materials Required (None)

Remove

1. Remove the top cover.
2. Locate and disconnect the power supply cable (see Figure 2, #1).
3. Locate the tab that holds the power supply in place (see Figure 2, #2).
4. Gently pull back the tab, lift the power supply up and slide it towards you off the tabs on the back of the case.
5. Lift the power supply from the case.

Replace

1. Position the power supply so that the three tabs on the back of the case slide into the power supply.
2. Lower the power supply into position so that the tab in the front clicks into place (see Figure 2, #2).
3. Reconnect the power supply cable (see Figure 2, #1).
4. Replace the top cover.

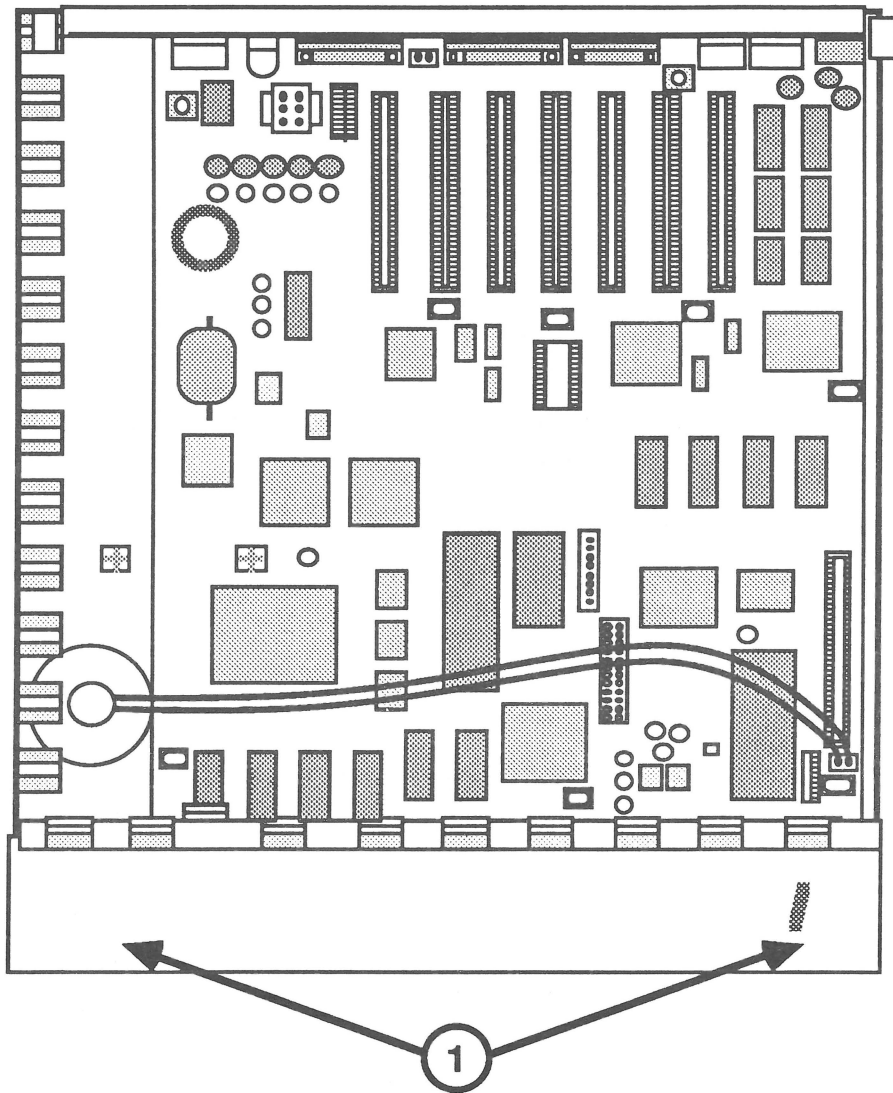

FIGURE 3

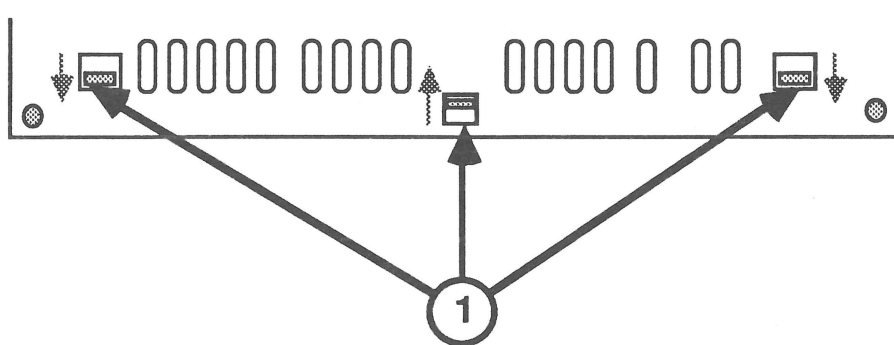

FIGURE 4

□ THE CASE HINGE

Materials Required Jeweler's screwdriver

Remove

1. Remove the top cover.
2. Remove the power supply.
3. Locate the case hinge (see Figure 3, #1).
4. Turn the machine over and remove the case hinge by inserting your finger or a small (jeweler's) screwdriver into each tab, one at a time (see Figure 4, #1). The case hinge will pop free when each tab is released.
5. Remove the case hinge.

Replace

1. Position the case hinge so that the tabs line up with the holes in the bottom case (see Figure 4, #1).
2. Gently pop the case hinge into place.
3. Replace the power supply.
4. Replace the top cover.

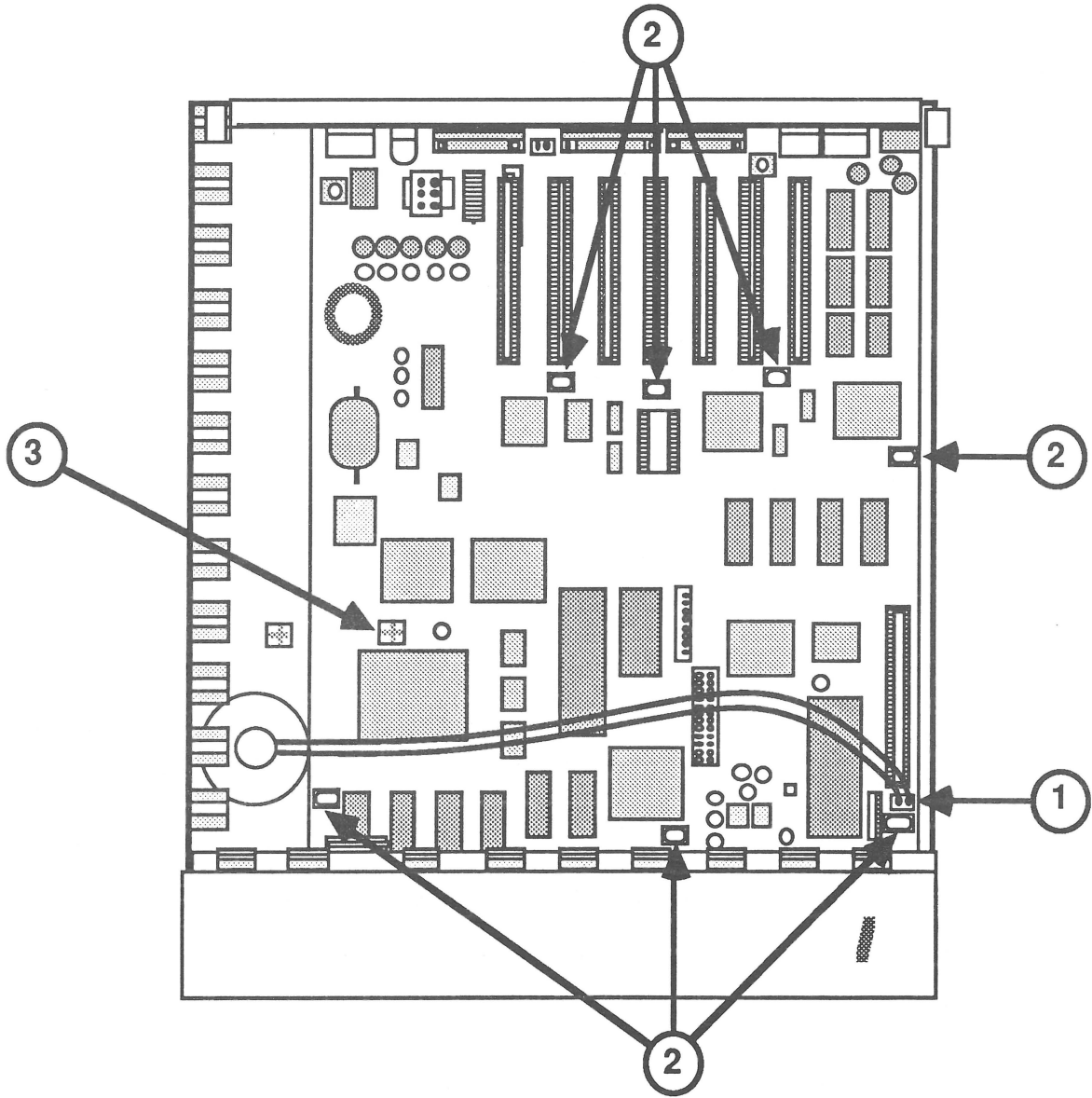

FIGURE 5

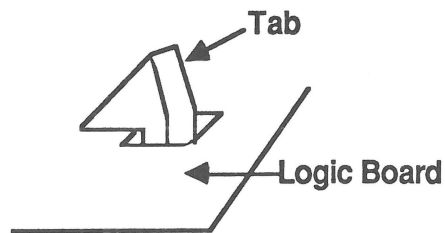

FIGURE 5a

□ MAIN LOGIC BOARD

The logic board comes in various configurations. The boards vary slightly in appearance, but can be used interchangeably.

Materials Required

Small pair of needlenose pliers

Remove

1. Remove the top cover.
2. Remove the power supply.
3. Remove the case hinge.
4. Disconnect the speaker wire (Figure 5, #1).
5. Locate the seven tabs (Figure 5, #2) that hold the logic board in position.

CAUTION: *Flex the board as little as possible when removing it. Excessive flex and force may damage the board.*

6. Starting at the front of the board, squeeze each tab (Figure 5a) one at a time, gently lifting the board up as you proceed to the rear of the board. Be sure all seven tabs (Figure 5, #2) have been released.
7. Lift the board toward you and remove it from the case.
8. If a metal EMI Fence (shield) is installed on the rear of the board, remove it.

Replace

1. Line up the connectors on the rear of the logic board with the openings on the rear of the case. Be sure to position the board so that the large mounting tab (Figure 5, #3) slips into position.
2. If you removed an EMI Fence, replace it.
3. Gently press the board onto the seven tabs (Figure 5, #2).
4. Connect the speaker wire (Figure 5, #1).

5. Replace the case hinge.
6. Replace the power supply.
7. Replace the top cover.

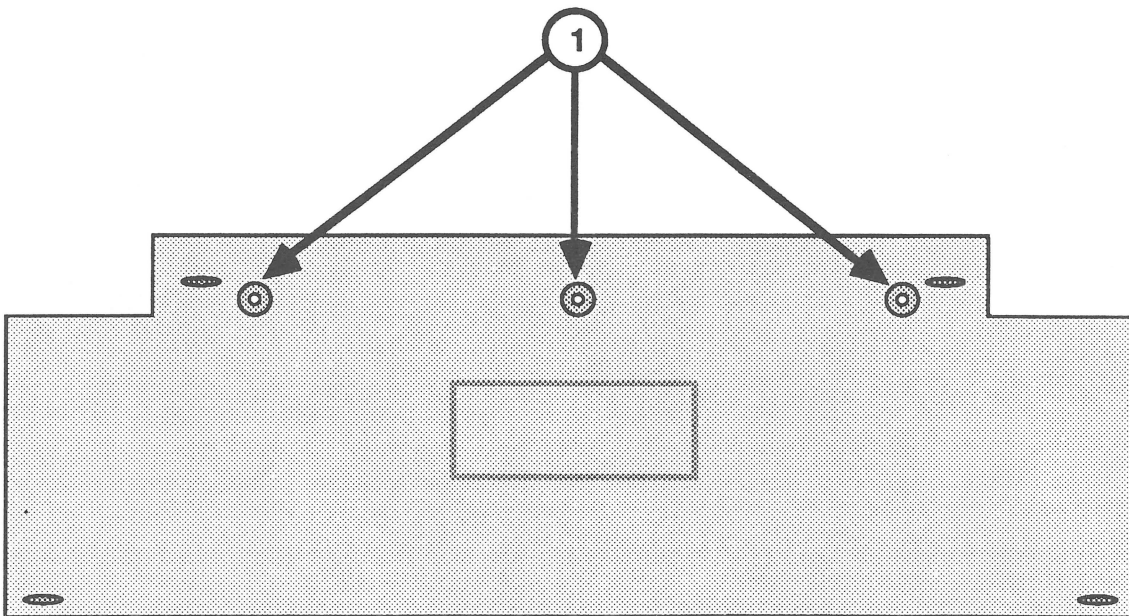

FIGURE 6

□ APPLE DESKTOP BUS KEYBOARD

Exchanging the Keyboard

If you are exchanging the entire ADB Keyboard, **do not** remove the keyboard mechanism. Send the entire unit (**without** the cable) in for exchange. This procedure is to be used for replacing keyswitches only.

Materials Required

Medium Phillips screwdriver

Remove

1. Disconnect the keyboard from the Apple Desktop Bus port.
2. Remove the three screws from the back of the keyboard (see Figure 6, #1). Remove the small rectangular piece from the front of the keyboard.
3. Lift the mechanical assembly out of the bottom case.
4. Use the replacement procedures for Apple IIc keyswitches in *You Oughta Know*.

Replace

1. Set the mechanical assembly back into the bottom case.
2. Position the rectangular piece onto the front of the keyboard.
3. Hold the rectangular plastic piece in place, turn the keyboard over, and install the three screws (see Figure 6, #1).

Apple IIGS

Section 3 – Diagnostics

□ CONTENTS

3.2	Introduction
3.2	General Information
3.2	Before You Start
3.2	Built-In Diagnostics
3.3	Things to Remember
3.5	Apple II Diagnostic Disk
3.5	Materials Required
3.5	Main Menu Selections
3.6	Choose Tests
3.9	Options
3.10	Special
3.11	Running the Diagnostics
3.14	Running the Memory Card Tests
3.16	Test Failures

□ INTRODUCTION

General Information

This section describes general procedures for using the 3.5- or 5.25-inch Apple II Diagnostic Disk on the Apple IIGs and IIGs, 1 MB. This diagnostic allows you to select various tests you wish to run and the order in which you wish to run them. It also allows you to run a continuous test and keep a record of any failed tests. This record will prove valuable for pinpointing problems that cause intermittent failures.

Before You Start

Read the subsection entitled Things to Remember before you run the diagnostics. It will give you specific hints for using the diagnostic.

Built-In Diagnostics

Before attempting to boot the disk-based diagnostics, run the built-in diagnostics. To run them, **disconnect the mouse** and hold down <Open-Apple> and <Option> while turning on the power. (To run the diagnostics if the power is on and the mouse is connected, hold down <Control>, <Open-Apple>, <Option>, and <Reset>. Release <Reset> first, then the other keys.)

The screen will display various patterns and solid colors, with a code displayed in the lower-left corner, for approximately one minute. The patterns and colors indicate that the RAM, ROM, and other components on the logic board are being tested.

Results

The results are displayed in the lower-left corner of the screen. **System Good** is accompanied by a high-pitched beep, **System Bad** by a low-pitched beep.

System Good

If you can access the built-in diagnostics and you receive the message **System Good**, connect a disk drive and continue with this section.

System Bad

If you cannot access the built-in diagnostics or you receive the message **System Bad**, exchange the keyboard or logic board and try again.

□ THINGS TO REMEMBER

Backup Information

1. **Make a backup disk before beginning!** When testing a defective Apple IIGS, it is possible to erase and/or damage a section of the disk.

The *System Utilities* disk (Rev. 2.1.1 or higher) is used for making a backup copy. Follow the instructions in the *System Utilities* manual.

Diagnostic Information

2. If you are going to select **Serial External Test**, the loopback cable must be installed.
3. To access the Help screen, hold down <Open-Apple> and <Shift>, and press ?.
4. Before booting the diagnostic, enter the Control Panel Program (refer to Section 4, Troubleshooting). Set the Keyboard Buffering option to **No**. Set the Display Language option to the language you want the keyboard to display, and select the correct Keyboard Layout for the keyboard that is connected. Verify that Slot 4 is set for the **Mouse Port** and Slot 7 is set for **Your Card**. Press <Return> to save the selections and quit the Control Panel Program. Turn off the Apple IIGS, insert the *Apple II Diagnostic Disk*, and reboot. If you do not use this method, the diagnostic may lock up or give false results.
5. When loading or saving selected test sequences to disk, use a known-good system and disk drive.
6. When testing multiple disk drives, unique names must be given to each disk in each drive. ProDOS is unable to recognize more than one drive with the same disk name.

Diagnostic Commands

7. Where input is required to start the next test (after video tests, for example), press <Spacebar>. If you press <Escape>, the testing will stop.
8. To abort the keyboard test, hold down <Control> and press C.

Choose
Tests

9. To make a selection, type the letter of the test or use the arrow keys until the selection is highlighted, and then press <Return>.
10. When chosen, the tests display a number that indicates the order in which the tests will be performed.
11. To deselect a test, type the letter of the test or use the arrow keys until the selection is highlighted; then press the <Delete> key. The numbers displayed will be corrected automatically. To deselect all tests, hold down <Open-Apple> and press <Delete>.

□ APPLE II DIAGNOSTIC DISK

Materials Required

Apple II Diagnostic Disk
Loopback cable (optional)
Apple IIGS Memory Expansion Card (optional)
Known-good UniDisk 3.5, UniDisk, DuoDisk, Apple 3.5,
or Apple 5.25 Drive
Apple IIGS/IIGS, 1 MB, or an Apple IIe that has the
retrofit kit installed

Main Menu Selections

The *Apple II Diagnostic Disk* main menu is
shown below.

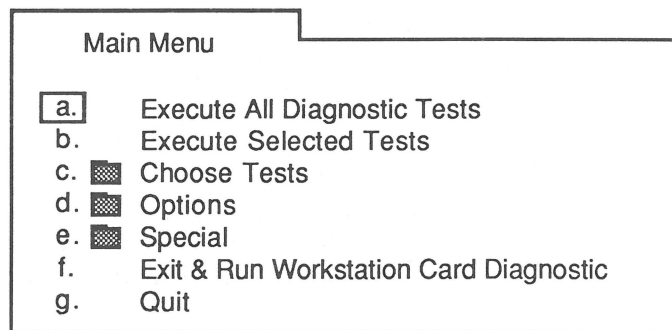

The following list describes each item in the main
menu:

Execute All Diagnostic Tests – Runs the standard Apple
IIGS test sequence.

Execute Selected Tests – Allows you to run only the
tests selected in the Choose Tests folder.

Choose Tests – Contains all the tests that can be
selected for the Apple IIGS.

Options – Contains various selections that allow you to
control how the tests are run.

Special – Contains various options for keeping track of
errors generated, for saving a test sequence, and for
loading a test sequence from a disk.

Exit & Run Workstation Card Diagnostic – Terminates the Apple IIGS diagnostic and starts the Apple II Workstation Card diagnostic. Refer to *Cross Family Peripherals, Volume Three* for instructions on running this portion of the diagnostic.

Quit – Stops all testing and displays a message saying **Shutdown and Restart the System.**

Choose Tests

The Choose Tests folder is shown below.

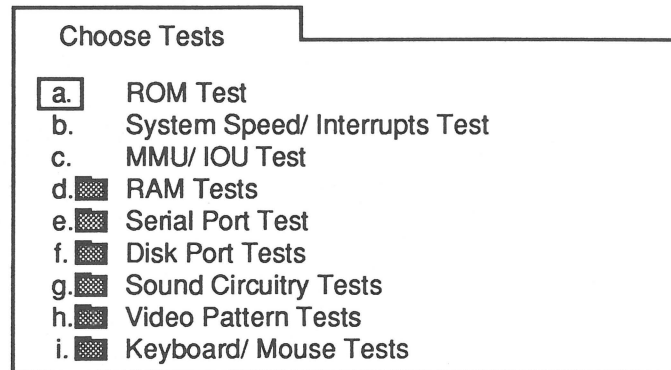

The following list describes the items in the Choose Tests folder:

ROM Test – Checks the ROM.

System Speed/Interrupts – Checks that the interrupts and both speeds (1 MHz and 2.8 MHz) are functioning correctly.

MMU/IOU Test – Checks the Memory Management Unit and the Input/Output Unit.

RAM Tests Folder

RAM Tests – This folder contains the following:

- Main Logic Board RAM Test – Checks the RAM on the logic board.
- IIGS Memory Expansion Card Test – Checks the RAM on an Apple IIGS Memory Expansion Card (if installed). This test will not run unless selected. Refer to "Running the Memory Card Tests" for further information.

- Clock RAM Test – Checks the RAM used for the clock and the clock timekeeping function.

**Serial Ports
Folder**

Serial Ports – This folder contains the following:

- Serial Internal Test – Checks the logic board circuitry that handles the serial port.
- Serial External Test (Loopback is required) – Checks the ports to be sure they are sending and receiving data correctly.
- Serial Crystal Test (Loopback is required) – Checks the crystal to be sure it is functioning correctly.

**Disk Port
Folder**

Disk Port – This folder contains the following:

- Disk Port Test – Checks the drive circuitry on the logic board for all 3.5- or 5.25-inch drives attached to the system. The disk in the drive must be formatted with ProDOS in order to be tested.

**Sound Tests
Folder**

Sound Tests – This folder contains the following:

- Sound Circuitry Test – Checks the specialized sound components and the sound RAM on the logic board.
- Speaker Tone Test – Checks the speaker by playing a sequence of beeps.

**Video
Pattern Tests
Folder**

Video Pattern Tests – This folder contains the following:

- Color Bar Test – Displays vertical color bars with the name of each color below.
- Character Generator Test – Displays the Swedish, German, Italian, Spanish, Danish, French, British, Domestic, and Domestic2 character sets.

- 80/40 Column Text Test – Displays a few lines of 80- and 40-column characters.
- Low-Resolution Graphics Test – Displays both pages (one and two) of the low-resolution graphics mode with bars at the top of the screen.
- High-Resolution Graphics Test – Displays both pages (one and two) of a grid of 9 vertical lines intersected by 8 horizontal lines.
- Double High-Resolution Graphics Test – Displays a grid of 18 vertical lines intersected by 8 horizontal lines.
- Super High-Resolution Graphics Test – The screen displays a grid of 11 vertical lines intersected by 21 horizontal lines.
- Screen Text Color Test – Displays the 16 possible border colors.

***Keyboard and
Mouse Tests
Folder***

Keyboard/Mouse Tests – This folder contains the following:

- ADB Domestic Keyboard – Displays a keyboard layout for the Apple Desktop Bus keyboard used on the Apple IIGs. The instructions are given at the bottom of the screen.
- Standard IIE Keyboard Test – Displays a keyboard layout for the standard Apple IIE keyboard. The instructions are given at the bottom of the screen.
- Extended IIE Keyboard Test – Displays a keyboard layout for the Apple IIE Extended Keyboard (with built-in keypad). The instructions are given at the bottom of the screen.

- Numeric Keypad Iie Test – Displays a keypad layout for the Apple Iie Numeric Keypad. The instructions are given at the bottom of the screen.
- Languages – Displays a list of languages available for the keyboard tests. The default setting is U.S.A. English. The language selected here must match the one in the Control Panel setting.
- ADB Mouse Test – Displays a pointer that can be moved around the screen and indicates whether the mouse button is pressed or not.
- Joystick/Paddle Test – Displays a range from 0 to 255 that can be adjusted to indicate whether the joystick/paddle works.

Options

When the Options folder is open, the following list of selections appears on the screen:

- Loop Tests Until Esc is Pressed
- Continue On Error Until Esc

If an option is selected, a check mark appears beside the item. To deselect an option, just select the same option again.

Special

The following selections appear when the Special folder is opened:

- Display Error Log – Displays the names of the tests that failed since the last clearing of the error log (up to 255 names).
- Clear Error Log – Erases the log from RAM.
- Clear Testing Status Line – Clears the iterations and failure counts displayed.
- Display Current System Status – Indicates the type of system, the ROM version, the amount of memory available, and the memory card status.
- Load Selected Test Sequence from Disk – Loads a previously saved test sequence. The sequence can then be executed.
- Save Selected Test Sequence to Disk – Saves a selected test sequence to the test disk.

When any of the above items is selected and <Return> is pressed, the action is performed.

Running the Diagnostics

The diagnostic program can be configured in various ways. All the tests can be run in their automatic sequence, or selected tests can be looped or run in an order you specify.

The diagnostic also has the ability to execute a test sequence that has been saved to the test disk. Saved test sequences make it easier to test upgraded Apple IIGS systems and other specially configured systems that require nonstandard tests (see "Customized Tests").

Note: The Apple IIGS, 1 MB logic board requires the *Apple II Diagnostic Disk*, version 4.0 or later.

Control Panel Setup

Before booting the diagnostic, enter the Control Panel Program and make the following selections:

- Set the Keyboard Buffering option to **No**.
- Set the Display Language option to the language you want the keyboard to display.
- Select the correct Keyboard Layout for the keyboard connected.
- Verify that Slot 4 is set for **Mouse Port**.
- Verify that Slot 7 is set for **Your Card**.
- Verify that Startup is set for **Scan**.

Press <Return> to save the selections and quit the Control Panel Program. Turn off the Apple IIGS, insert the *Apple II Diagnostic Disk*, and reboot. If you do not use this method, the diagnostic may lock up or give false results.

Standard Test

1. Install the appropriate loopback connector and the memory card, if available.

If they are not available, type N when the diagnostic asks you if they are installed. The testing will continue.

2. Insert the *Apple II Diagnostic Disk* and power on the system.
3. Type the letter a or use the arrows to select **Execute All Diagnostic Tests**, and press <Return>.

4. To continue after certain tests (for instance, **Speaker Tone** and **Video Pattern** tests), press <Spacebar>. When an error is encountered, the testing stops and an alert box specifies which test failed. Refer to "Test Failures" at the end of this section for the appropriate actions to perform.
5. On completion, **Testing Finished** displays in the alert box.

Customized Tests

1. If you are going to test the serial ports and the memory card, install these items now.
2. Insert the *Apple II Diagnostic Disk* and power on the system.
3. Type the letter c or use the arrows to select **Choose Tests**, and press <Return>.
4. From the Choose Tests menu, select the first three tests (if desired) and press <Return>.

Select the other test folders and press <Return> to display them. Select the tests you wish to run from each folder and press <Return>. To deselect a test, use the letters or arrows to select the test and press <Delete>.

Saving and Loading Test Sequences

5. To save your customized test sequence, return to the main menu and select **Special**. Select **Save Selected Test Sequence to Disk** and press <Return>.

You now have saved the selected test sequence to disk. The sequence may be loaded when needed using **Load Selected Test Sequence From Disk**.

6. On completion, return to the main menu, select **Execute Selected Tests**, and press <Return>.
7. To continue after certain tests (for instance, **Speaker Tone** and **Video Pattern** tests), press <Spacebar>. If an error is encountered, the testing stops and an alert box specifies which test failed.
8. On completion, **Testing Finished** displays in the alert box.

Continuous Test

A continuous (looping) test is possible with all tests. Select the tests you wish to loop by following the instructions under "Customized Test" (see above). Follow the steps below to run a continuous test.

1. After you have chosen the tests you want to run, return to the main menu, select **Options**, and press <Return>.
2. From the menu select **Loop Tests Until Esc is Pressed** and press <Return>.

A check mark indicates which tests have been selected.

3. Select **Continue On Error Until Esc** if you want to continue looping regardless of the error until <Escape> is pressed. If you do not select this option, the testing will halt when an error is encountered.

Errors will be logged to RAM.

4. Return to the main menu, select **Execute Selected Tests**, and press <Return>.

The tests will run (depending on your selection in step 3) continuously until an error occurs or <Escape> is pressed. If <Escape> is pressed, the looping is canceled.

If you press <Escape> to stop the testing, you can then check for errors by selecting **Special** and pressing <Return>, then selecting **Display Error Log**.

5. If you are going to run the test again, be sure to clear the error log and the status line to reselect **Loop Tests Until Esc is Pressed** before returning to the main menu.

Running the Memory Card Tests

The Apple IIGs Memory Expansion Card test is located on the *Apple II Diagnostic Disk*. The test can be run alone or with other tests in the order you specify. For information on Memory Card configuration, refer to Section 5, Additional Procedures.

Materials Required

Known-good Apple IIGs or IIGS, 1 MB
3.5-inch (or 5.25-inch) disk drive
Known-good RAM chips
Apple IIGs Memory Expansion Card
Apple II Diagnostic Disk

Testing the RAM

1. Install the Apple IIGs Memory Expansion Card into the memory slot.
2. Start up the *Apple II Diagnostic Disk*. Open the folder **RAM Tests**, select **Apple IIGs Memory Expansion Card Test** and run the test.

A screen will appear stating the total number of banks installed on the card and the number of the bank it is currently testing. The test takes from 10 to 15 minutes to run.

3. Three types of failures are possible on the Apple IIGs Memory Expansion Card: defective replaceable RAM chips, defective soldered RAM chips, or out-of-specification RAM chips.
 - a) If any replaceable RAM chips fail, the screen will list numbered location(s) on the board.

Note: The top row of RAM on the card has the markings UA1 through UA16 above the sockets (UA1 through UA8 are not replaceable). The bottom row of RAM on the card has the markings UB1 through UB16 below the sockets.

- 1) Locate and replace the failed RAM with known-good RAM chips.
 - 2) Retest the card.
 - 3) Repeat steps 1) and 2) until the card passes.
- b) If any of the soldered RAM chips are bad, the screen will display the message **Soldered IC's**.

- 1) Remove all the RAM from the customer's card.
 - 2) Test the module used for exchange.
 - 3) Install the customer's known-good RAM onto the new module.
- c) If any replaceable RAM chips are out-of-specification, the screen will display the message **Out of Spec IC(s)** and will list the numbered location(s) on the board.
- 1) Locate and replace the failed RAM with known-good RAM chips.
 - 2) Retest the card.
 - 3) Repeat steps 1) and 2) until the card passes.

Test Failures

When a test fails, the following or a similar message will be displayed:

Report the following information on the repair form:

ROM/CPU Test Failed

Refer to the Apple Service Technical Procedures

The following is a list of the tests, along with the recommended remedial actions.

Test

Remedial Action

- *ROM/CPU* – Exchange logic board.
- *System Speed/Interrupts* – Exchange logic board.
- *MMU/IOU* – Exchange logic board.
- *Main Logic Board RAM* – Exchange logic board.
- *Memory Expansion Card* – Refer to Section 5, Additional Procedures.
- *Clock RAM* – Exchange logic board.
- *Serial Internal* – Exchange logic board.
- *Serial External*
 1. Exchange loopback cable.
 2. Exchange logic board.

Tests

Remedial Action

- *Disk Port*
 1. Exchange drive.
 2. Exchange logic board.

- *Sound Circuitry*
 1. Exchange logic board.
 2. Exchange speaker.

- *Speaker*
 1. Exchange speaker.
 2. Exchange logic board.

- *All Video*

– Exchange logic board.

- *ADB Domestic Keyboard*
 1. Exchange cable.
 2. Exchange keyboard.
 3. Exchange logic board.

- *Standard Apple IIe Keyboard*
 1. Exchange cable.
 2. Exchange keyboard.
 3. Exchange logic board.

- *Extended Apple IIe Keyboard*
 1. Exchange cable.
 2. Exchange keyboard.
 3. Exchange logic board.

- *ADB Mouse*
 1. Exchange mouse.
 2. Exchange cable for keyboard.
 3. Exchange keyboard.
 4. Exchange logic board.

- *Joystick/Paddle*
 1. Exchange joystick/paddle.
 2. Exchange logic board.

Apple IIGS

Section 4 – Troubleshooting

□ CONTENTS

4.2	Introduction
4.2	General Information
4.2	Before You Start
4.2	How to Use the Symptom Chart
4.3	Things to Remember
4.5	Apple IIGS Symptom Chart
4.5	System Problems
4.5	Video Problems
4.6	Drive Problems
4.6	Peripheral Problems
4.7	Miscellaneous Problems

□ INTRODUCTION

General Information

This troubleshooting section can be used if the diagnostics are unable to detect a module failure or if the diagnostic diskette cannot be booted. After repairing the system, the diagnostic should be run to verify system operation.

Before You Start

Read the section entitled "Things to Remember" before you begin troubleshooting. There are numerous things you need to know about the Apple IIGS in order to troubleshoot the system effectively.

How to Use the Symptom Chart

The symptom chart has two columns. The left hand column lists the problem of the defective system, the right hand column lists corrective actions. For each symptom, perform the corrective action(s) in the order listed. If a corrective action does not fix the problem, proceed to the next step.

If a board is replaced but does not fix the problem, the original board should be reinstalled before you perform the next step.

□ THINGS TO REMEMBER

Safety Information

1. Follow the basic ESD precautions when troubleshooting. (Refer to Section 2, Take-Apart, for more information.)
2. Be sure the power is off before installing any interface cards, connecting any peripherals to the ports on the rear of the system, **or** connecting the keyboard to the Apple DeskTop Bus.

Control Panel Information

3. The Apple IIGS is configured by accessing the *Control Panel*. The Control Panel allows you to change the video display modes, the sound, the system speed, the clock, the language, the slots, port 1 and port 2, and the RAMdisk. (Refer to the *Apple IIGS Owner's Manual* for more detailed information.)
4. To gain access to the Control Panel on an Apple IIGS, hold down the <Option> key as you turn the system on. A menu with four possible selections will appear. Select number 1 and press <Return>. This will bring you to the Desk Accessories window.

To gain access to the Control Panel on an upgraded Apple IIe, hold down the <Control>, <Closed-Apple>, and <Reset> keys as you power on the system. Release the <Reset> key. When the Control Panel appears, release the other keys.

5. On an upgraded Apple IIe, use the <Closed-Apple> key where Apple IIGS instructions ask for the <Option> key.

Port and Slot Configuration

6. The printer port is configured to work automatically with the ImageWriter series of printers. There are two ways to set the port configuration: from an application program or from the Control Panel.
7. The Memory Expansion slot is designed only for the Apple IIGS Memory Expansion Card. **Do not** insert any other card into this slot unless the manufacturer specifies to do so.

- Each port on the Apple IIGS is designed to impersonate an Apple II slot containing a card.

<u>Device</u>	<u>Connected To</u>	<u>Looks like</u>
Printer	Port 1	Slot 1
Modem	Port 2	Slot 2
Drives		
3.5	Disk Drive Port	Slot 5
5.25	Disk Drive Port	Slot 6
AppleTalk	Port 1 or 2	Slot 7
Mouse	Mouse Port Keyboard	Slot 4

Because each port impersonates a slot, you can't have both the port and the corresponding slot active at the same time. You activate one or the other by using the Control Panel. When a slot is activated, the words **Your Card** replace the words describing the port.

- The configuration of ports and/or slots which is specified within an application overrides the Control Panel setting.

□ APPLE IIGS SYMPTOM CHART

System Problems

Solutions

- *Does not boot*
 1. Check battery (refer to "Battery Verification" in Section 5, Additional Procedures).
 2. Exchange logic board.
 3. Exchange power supply.

- *Shuts down intermittently*
 1. Check battery (refer to "Battery Verification" in Section 5, Additional Procedures).
 2. Exchange logic board.
 3. Exchange power supply.

- *Screen is totally dark and LED is not lit*
 1. Check battery (refer to "Battery Verification" in Section 5, Additional Procedures).
 2. Exchange logic board.
 3. Exchange power supply.

- *Fails ROM/CPU diagnostic test*
 1. Check that the diagnostic is the correct version (version 4.0 or later for the Apple IIGS, 1 MB logic board).
 2. Exchange logic board.

Video Problems

Solutions

- *Display is fuzzy on a known-good monitor*
 1. Verify Control Panel setting for video.
 2. Verify that the application software supports the monitor (e.g., color or monochrome).
 3. Exchange logic board.

- *Garbage displayed on known-good monitor; no beep*
 1. Exchange logic board.
 2. Exchange power supply.

- *Cosmetically flawed video display*
 1. Verify VGC revision; if necessary upgrade the VGC (refer to "VGC Upgrade" in Section 5, Additional Procedures).
 2. Exchange power supply.

- *No video, no beep; power light on*
 1. Exchange logic board.
 2. Exchange power supply.
- *Cannot adjust horizontal hold on monitor*
 1. Verify Control Panel setting is 60 Hz for domestic use or 50 Hz for international use.
 2. Exchange logic board.

Drive Problems

Solutions

- *Won't boot from known-good disk drive*
 1. Verify Control Panel setting for correct slot assignment.
 2. Exchange software.
 3. Exchange logic board.
- *Known-good drive does not turn on*
 1. Verify Control Panel setting for correct slot assignment.
 2. Exchange logic board.

Peripheral Problems

Solutions

- *No keyboard output or wrong output is displayed*
 1. Verify Control Panel setting for correct language selection.
 2. Exchange Apple DeskTop Bus cable.
 3. Exchange keyboard.
 4. Exchange logic board.
- *No output from specific keyswitch(es)*
 1. Exchange keyboard or keyswitches.
 2. Exchange logic board.
- *Mouse cursor moves too fast or too slow*
 1. Verify Control Panel setting for desired mouse tracking and speed.
 2. Exchange logic board.
- *No audio*
 1. Verify Control Panel setting for sound.
 2. Exchange speaker.
 3. Exchange logic board.

- *Problems transmitting and receiving data with a known-good modem*
 1. If a port is being used, verify that modem DIP switch settings match the settings in the Control Panel. If a slot is being used, verify that modem DIP switch settings match the settings on the interface card and that the correct slot is selected in the Control Panel.
 2. Exchange logic board.

- *Can't read or write to ProFile*
 1. Add a jumper to the interface card (refer to "ProFile Interface Card Modification" in Section 5, Additional Procedures).
 2. The ROM must be P/N 341-0299-B to work with operating system 4.0 or higher.

- *Won't print to a known-good printer*
 1. If a port is being used, verify that printer DIP switch settings match the settings in the Control Panel. If a slot is being used, verify that printer DIP switch settings match the settings on the interface card and that the correct slot is selected in the Control Panel.
 2. Exchange logic board.

- *Unidentifiable system crashes when accessing the Hard Disk 20SC*
 1. Check the ROM version on the interface card (refer to "SCSI Interface Card ROM Upgrade" in Section 1, SCSI Interface Card and SCSI High-Speed Interface Card, under the *Apple II Family Cards* tab).
 2. The ROM must be 341-0437-A to work with operating system 4.0 or higher.

Miscellaneous Problems

Solutions

- *No power light, no video*
 1. Exchange AC power cord.
 2. Exchange power supply.
 3. Exchange logic board.

- *Programs run erratically and often crash*
 1. Verify Control Panel setting for speed (normal or fast). Different software requires different settings.
 2. Exchange logic board.

- *System crashes or locks up randomly*

1. Verify that the RAM on the Apple IIGS Memory Expansion Card is standard Apple RAM (refer to Section 5, Additional Procedures). If the RAM is not Apple RAM, or does not meet the requirements of Apple RAM, replace it with Apple RAM.
2. Some Apple IIGS Memory Expansion Cards and Memory Expansion Kits shipped from Apple may contain RAM chips that do not meet the "CAS before RAS" criteria. Replace the socketed RAM if either of the following conditions exist:
 - The code "**UK**" is stamped beneath the NEC name
 - The code "**Japan**" is stamped beneath the NEC name **and** the letter "P" is the **first letter** in the date code (the fifth character)

Note: If the RAM to be replaced is soldered to the PCA, replace the Memory Expansion Card.

Apple IIGS

Section 5 – Additional Procedures

□ CONTENTS

5.2	Apple IIGS Fan Kit
5.2	ProFile Interface Card Modification
5.4	Apple IIGS Memory Expansion Card
5.4	Introduction
5.6	Troubleshooting
5.6	ROM and Video Graphics Controller Upgrades
5.6	Introduction
5.6	ROM Upgrade
5.8	VGC Upgrade
5.10	Keyswitches
5.11	Battery Verification
5.11	Introduction
5.11	Verification Procedure
5.13	Battery Replacement
5.13	Introduction
5.14	Apple IIGS
5.16	Apple IIGS, 1 MB
5.18	Shield Tabs
5.18	Apple IIGS
5.19	Apple IIGS, 1 MB

□ APPLE IIGS FAN KIT

The optional Apple IIGS fan uses the vents on the top and bottom of the case to circulate fresh air through the inside of the case. The fan keeps the system running cooler and prolongs system life. The user installs the fan with the instructions provided in the *Apple IIGS Fan Kit Owner's Guide*.

The fan is mounted on the power supply by plastic hooks that snap into place. The connector from the fan is then plugged into two prongs marked *fan* on the logic board (located between the RGB monitor port and the disk drive port).

□ PROFILE INTERFACE CARD MODIFICATION

Some ProFile interface cards cause incompatibility problems when used with the Apple IIGS. Adding a jumper wire, as described in the following procedure, corrects the problem.

Materials Required

Soldering iron
Solder sucker
60/40 resin core solder
Small wire cutters
Piece of insulated wire with both ends stripped of about 1/4 inch of insulation

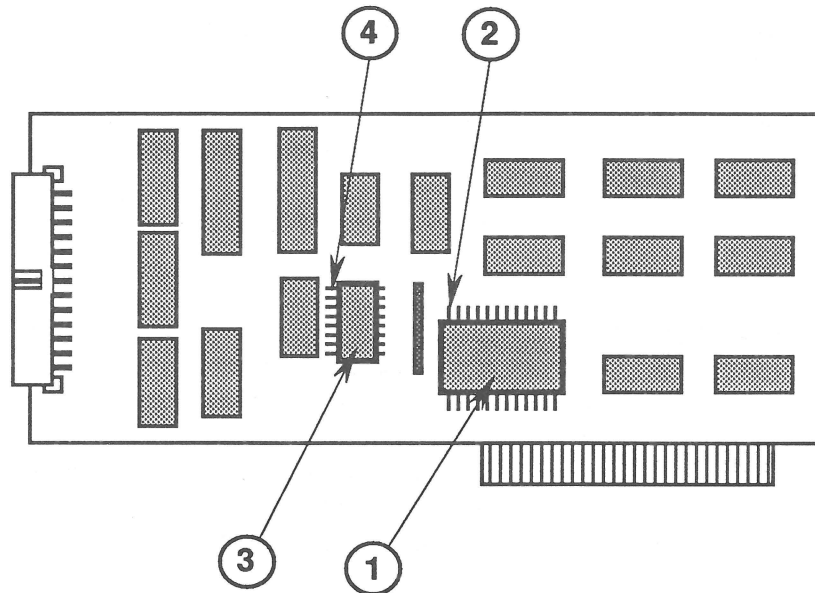

FIGURE 1

Procedure

1. On the IC at C6 (Figure 1, #1), locate pin 12 (Figure 1, #2).
 2. On the IC at B4 (Figure 1, #3), locate pin 1 (Figure 1, #4).
 3. Turn the board over and verify the locations on the back of the board.
- Note:** If a jumper is already installed between these pins, exchange the interface card.
4. Solder one end of the wire to pin 1 on the IC at B4.
 5. Solder the other end of the wire to pin 12 on the IC at C6.
 6. Install the interface card in the Apple IIGS and verify that the Control Panel is set correctly. Try to read and write to the ProFile. If the original problem persists, refer to the *ProFile Technical Procedures* for troubleshooting information.

□ APPLE IIGS MEMORY EXPANSION CARD

Introduction

The Apple IIGs Memory Expansion Card adds 256K, 512K, or 1 MB of RAM to the 256K of RAM built into the Apple IIGs. The card is installed in the Memory Expansion slot on the Apple IIGs logic board.

RAM Installation

Only Apple RAM, or RAM that meets the following specifications, should be installed on the Apple IIGs Memory Expansion Card:

- The minimum speed must be 150 nanoseconds.
- The configuration must be 256K by 1 bit.
- There must be CAS before RAS refresh.

RAM chips identified by the diagnostic as **Out of Spec IC** will not work on Apple products and need to be replaced.

There is no way to physically identify whether a RAM chip has CAS before RAS refresh. It is important to specify this requirement when ordering RAM from non-Apple vendors.

256K Configuration

The dark rectangles in Figure 2 indicate the location of the RAM chips for 256K. These eight chips are soldered onto the card at the locations labeled UA1 through UA8 and are not replaceable.

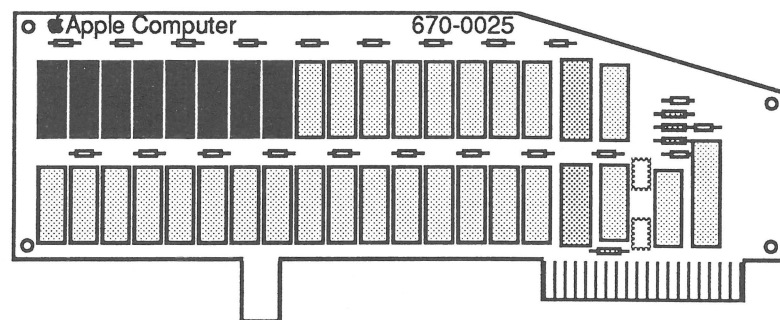

FIGURE 2

512K Configuration

The dark rectangles in Figure 3 indicate the location of the RAM chips for 512K. (The 256K RAM locations described above are included.) The eight additional chips (256K) must be installed in the sockets at locations UA9 through UA16 on the card. Jumper J2 (Figure 3, #1) must be installed for the card to "see" the 512K RAM.

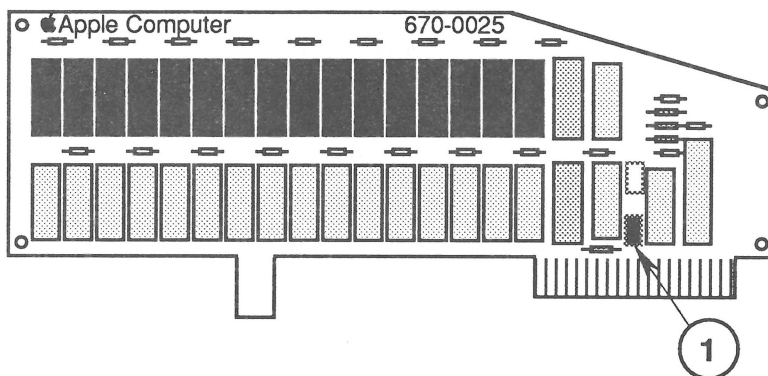

FIGURE 3

1 MB Configuration

The dark rectangles in Figure 4 indicate the location of the RAM chips for 1 MB. (The 512K RAM locations described above are included.) The 16 additional chips (512K) must be installed at the locations labeled UB1 through UB16 on the card. Jumpers J2 (Figure 4, #1) and J1 (Figure 4, #2) must be installed for the card to see the full 1 MB.

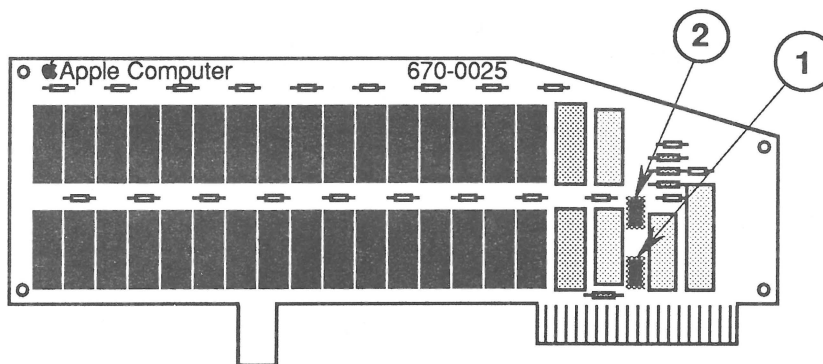

FIGURE 4

Troubleshooting

Use the *Apple II Diagnostic Disk* to assist you in troubleshooting the Apple IIGS Memory Expansion Card. Refer to Section 3, Diagnostics for additional information.

The Memory Expansion Card exchange module is shipped **without** socketed RAM. All socketed RAM must be removed from the card before returning the card to Apple.

Note: Some Apple IIGS Memory Expansion Cards have all the RAM soldered to the card. To exchange this type of card, you will need to fill out two SRO forms, one for the Memory Expansion Card and one for the additional 24 RAM chips.

□ ROM AND VIDEO GRAPHICS CONTROLLER UPGRADES

Introduction

There are two IC upgrades available for the Apple IIGS:

- ROM
- Video Graphics Controller (VGC)

ROM Upgrade

The ROM upgrade corrects some minor bugs and provides enhancements for future software releases. The old ROM is P/N 342-0077-A; the new replacement ROM is P/N 342-0077-B.

Materials Required

ESD equipment
IC extractor
ROM P/N 342-0077-B

Procedure

1. Set up the ESD equipment (refer to *You Oughta Know*).
2. Remove the top cover.

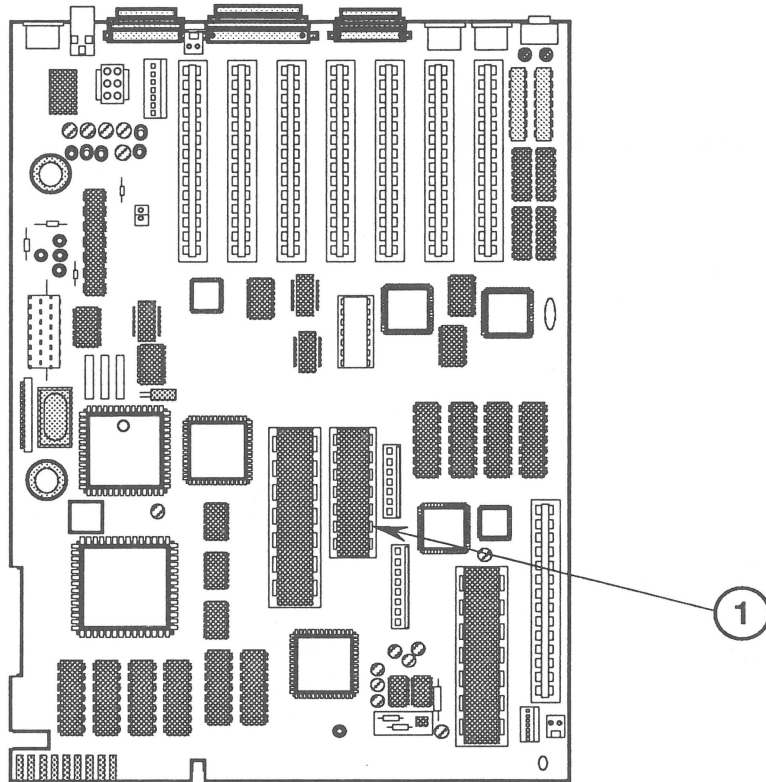

FIGURE 5

3. Locate the ROM at location H10 (Figure 5, #1), and verify that it is the old ROM (P/N 342-0077-A).
4. Using an IC extractor, remove the old ROM installed at location H10 (Figure 5, #1).
5. Install the new ROM in the same location, H10 (Figure 5, #1). The notch at one end of the ROM should be installed facing the front of the machine.
6. Run the diagnostics to verify that the machine is functioning correctly.

VGC Upgrade

The VGC upgrade corrects screens that may be cosmetically flawed in various modes of display. The VGC is located at H2 on the Apple IIGS logic board.

Defective VGCs

The following is a list of the VGCs that display this problem and should be replaced:

<u>Vendor</u>	<u>Number</u>
AMI	344S0046-1
AMI	344S0046-A

Good VGCs

The following VGC versions, if already installed, do **not** need to be replaced:

<u>Vendor</u>	<u>Number</u>
AMI	344S0046-2
AMI	344S0046-B

Replacement VGCs

The following are versions of the VGC that should be installed to correct the display problem. Any of the following versions can be used:

<u>Vendor</u>	<u>Number</u>
AMI	344S0046-2
AMI	344S0046-3
AMI	344S0046-4
AMI	344S0046-B
AMI	344S0046-C
AMI	344S0046-D
IMP	344S0056-A
IMP	344S0056-1

Materials Required

ESD equipment
VGC IC extraction tool (special tool)
VGC, as indicated above

Procedure

1. Set up the ESD equipment (refer to *You Oughta Know*).
2. Remove the top cover.
3. Remove the power supply.
4. Locate the VGC at location H2 (Figure 6, #1) and verify that it needs to be replaced by comparing the vendor and number on the IC with the list above.

5. Remove the logic board.

CAUTION: To prevent physical damage to the VGC socket and the logic board, the logic board must be removed before attempting to use the special VGC extraction tool.

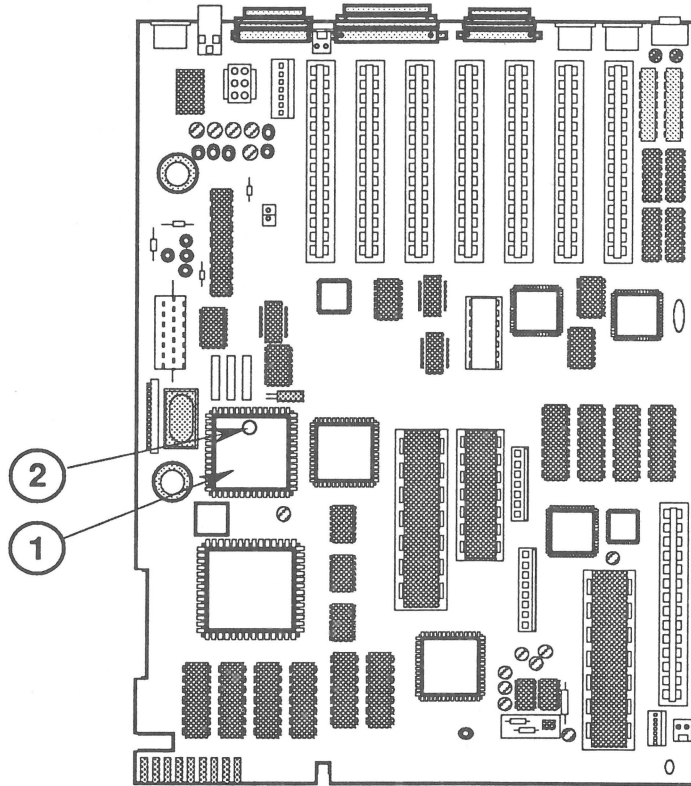

FIGURE 6

6. Remove the old VGC installed at location H2 (Figure 6, #1) using the VGC extraction tool.
7. Using the VGC extraction tool, install the new VGC in the same location, H2 (Figure 6, #1). The dot at pin 1 on the IC should face the rear of the machine (Figure 6, #2).
8. Run the diagnostics to verify that the machine is functioning correctly.

□ KEYSWITCHES

The Apple IIGS can use two types of keyswitches: Alps or SMK. To replace a faulty keyswitch, you must first identify the type currently installed.

The Alps keyswitch (Figure 7) is identified by the orange stem. The overall shape of the switch is square with no rounded corners.

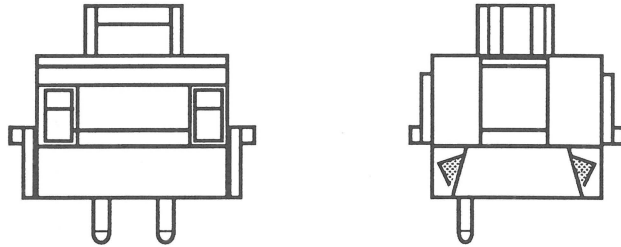

FIGURE 7

The SMK keyswitch (Figure 8) is identified by the white stem. The corners at the top of the keyswitch are rounded.

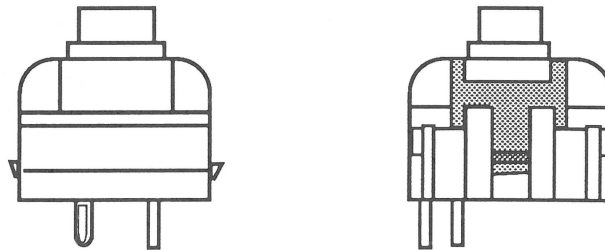

FIGURE 8

□ BATTERY VERIFICATION

Introduction

The Apple IIGS and Apple IIGS, 1 MB, logic boards each have a long-life lithium battery. Use the following procedure to check battery operation. If the battery falls below specifications, it must be replaced (refer to "Battery Replacement" in Section 5, Additional Procedures).

WARNING: *Lithium batteries, the type used in the Apple IIGS and Apple IIGS, 1 MB, have some potential for explosion if improperly handled. Follow the procedure below exactly as written.*

Materials Required

Voltmeter

Verification Procedure

1. Be sure the power is off. Then remove the logic board from the Apple IIGS and Apple IIGS, 1 MB.
2. Locate the lithium battery. Figure 9, #1 shows the location of the battery on a Apple IIGS logic board; Figure 10, #1 shows the battery location on an Apple IIGS, 1 MB logic board.

3. Set the voltmeter range to measure 10 volts DC.

Note: The battery in the Apple IIGS is installed in a plastic battery holder. It may be necessary to remove the battery holder cover (Figure 10, #2) and pull out the battery by hand to measure battery voltage.

4. Touch and hold the positive probe of the voltmeter to the positive side of the battery. The positive side of the battery is marked "+" on the logic board.
5. Touch and hold the ground probe of the voltmeter to the negative side of the battery.
6. The reading for a good battery should be above 2.8 volts.

If the battery voltage is below 2.8 volts, replace the battery. To replace the Apple IIGS or Apple IIGS, 1 MB battery, refer to "Battery Replacement" in this section.

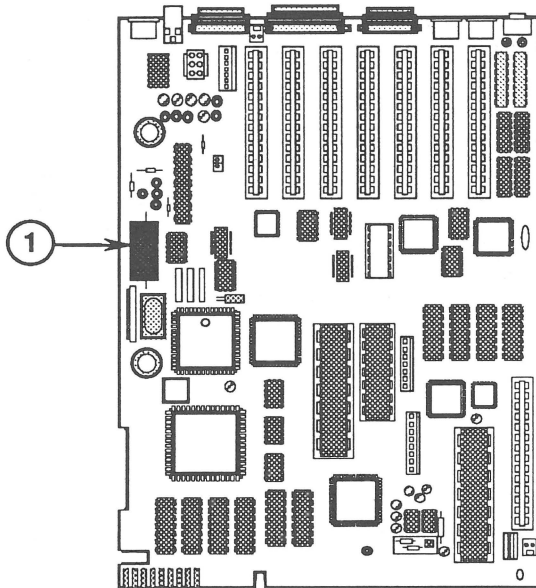

FIGURE 9

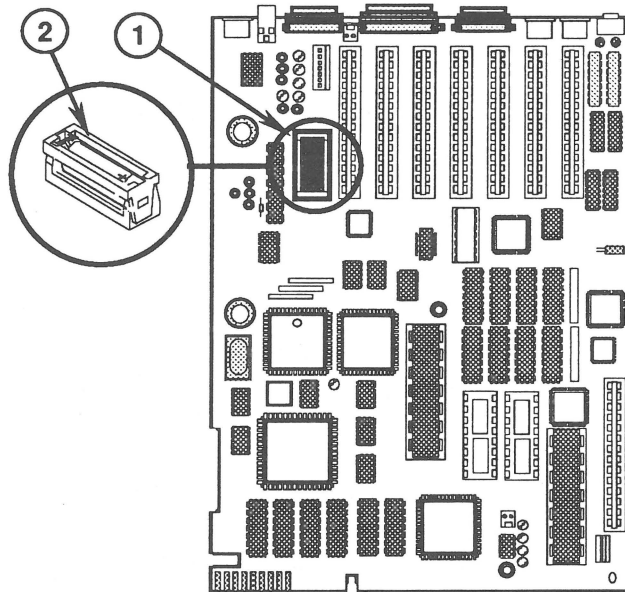

FIGURE 10

□ BATTERY REPLACEMENT

Lithium thionyl chloride batteries, the type used in the Apple IIGS, have a potential for explosion if improperly handled. The following precautions should be taken when storing, handling, and disposing of lithium batteries:

- Lithium batteries should be stored in a designated, well-marked area with limited access.
- Apple's lithium batteries are sealed in individual zip-lock wrappers. Upon receipt, the batteries should be inspected for integrity of their wrappers and should be stored in the same packaging in which they were received.
- Lithium batteries cannot be recharged and therefore will require disposal when dead. In addition to its explosive potential, lithium is water reactive **and must be disposed of as a hazardous waste**. Therefore, Apple recommends the following course of action:

After removing a dead battery from a board, clip off the lead wires and place the battery into the zip-lock wrapper and packaging from which the replacement battery was taken. Mark the battery *DEAD* and return it to Apple, where it will be disposed of following EPA guidelines.

Introduction

The Apple IIGS and IIGS, 1 MB logic boards contain a single, long-life, lithium battery; if a battery fails, replace it according to the appropriate procedure.

Apple II GS

The battery on the Apple IIGS is soldered directly to the logic board. This procedure involves unsoldering the defective battery and soldering in a new one.

Materials Required

Soldering iron
Solder sucker
60/40 resin core solder
Small wire cutters
Battery

Remove

1. Remove the Apple IIGS logic board from the case. (Refer to Section 2, Take-Apart.)
2. Locate the battery on the front of the logic board (Figure 11, #1). Turn the logic board over. The battery is held in place by two soldered leads. Apply fresh solder to the two connections.
3. Desolder the two connections.

CAUTION: Do not force the connections free. Force can remove the traces on the board. Repeat step 3 if you have problems.

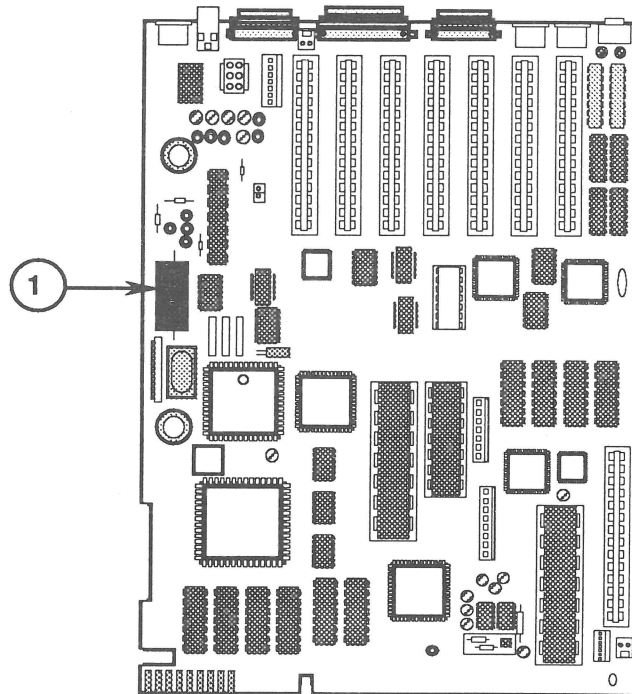

FIGURE 11

4. Package and label the old battery as directed in the beginning of this subsection, and return the battery to Apple for proper disposal.

Replace

1. Insert the new battery so that it is flush with the board. Be sure to orient the battery so that the end marked "+" matches the "+" on the logic board.
2. Solder the battery into place and then clip the excess ends from the back of the board. A length of about 1/16 inch is sufficient.
3. Replace the logic board. (Refer to Section 2, Take-Apart.)
4. Set the clock by using the Control Panel.

Apple II GS, 1 MB

A dead battery needs to be removed from the battery holder and replaced. No soldering is involved.

Materials Required

Small, flat-blade screwdriver
Battery

Remove

1. Remove the Apple IIGS logic board from the case. (Refer to Section 2.)
2. Locate the battery holder (Figure 12, #1). Remove the plastic cover by inserting a small, flat-blade screwdriver into the top (Figure 12, #2) of the holder, and gently pushing the screwdriver through the hole (Figure 12, #3) on the side of the battery holder. The battery holder cover will lift off.

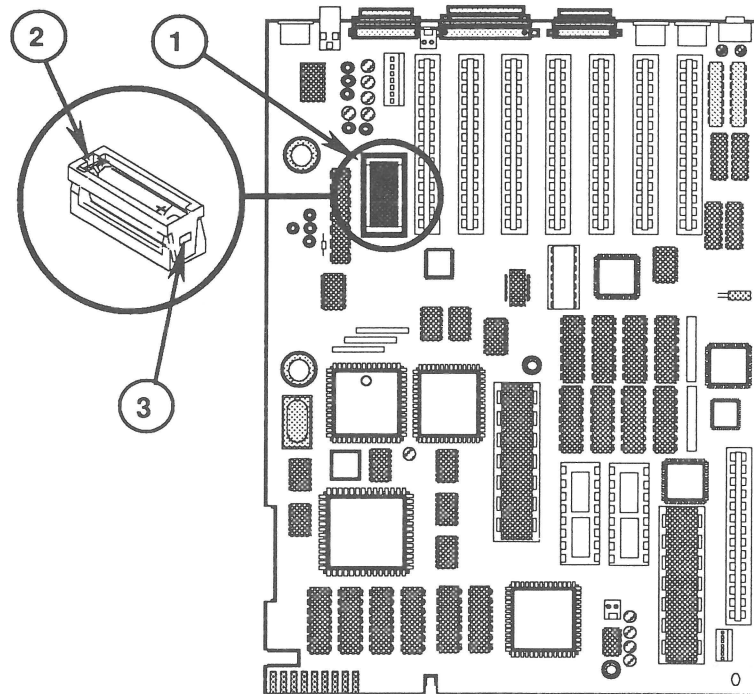

FIGURE 12

3. Use your fingers to remove the battery from the battery holder.
4. Package and label the old battery as directed in the beginning of this subsection, and return the battery to Apple for proper disposal.

Replace

1. Orient the new battery so that the end marked "+" matches the "+" on the main logic board. Insert the battery in the battery holder, and replace the plastic cover.
2. Replace the logic board. (Refer to Section 2, Take-Apart.)
3. Set the clock by using the Control Panel.

□ SHIELD TABS

Apple IIGS

On the Apple IIGS, the tabs on the metal shield must be bent at approximately a 45-degree angle (Figure 13, #1) to form a good metal-to-metal contact between the tabs and the metal portion of the I/O ports.

Use a small, flat-blade screwdriver to carefully bend the metal shield tabs to approximately a 45-degree angle.

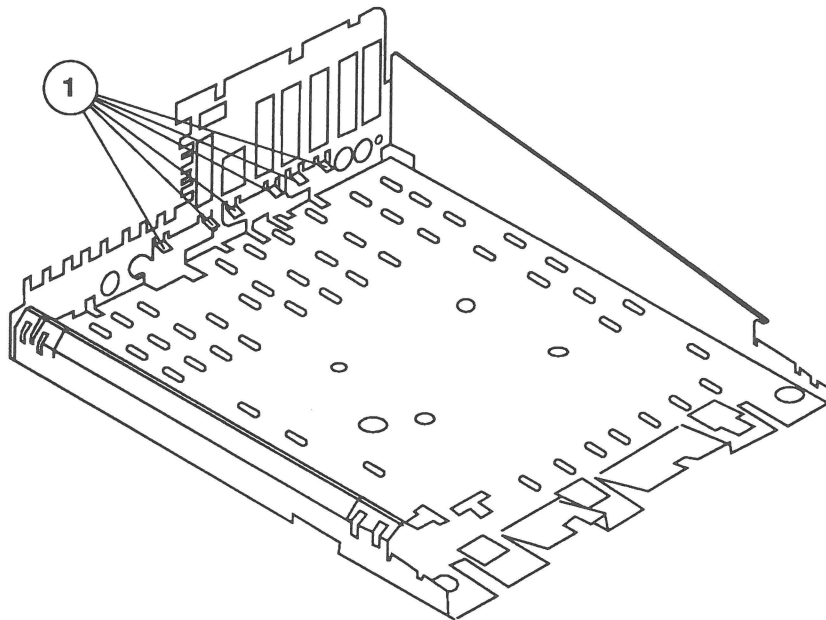

FIGURE 13

Apple IIgs, 1 MB

On the Apple IIgs, 1 MB, the tabs on the metal shield must be in a vertical position, flush against the plastic case (Figure 14, #1).

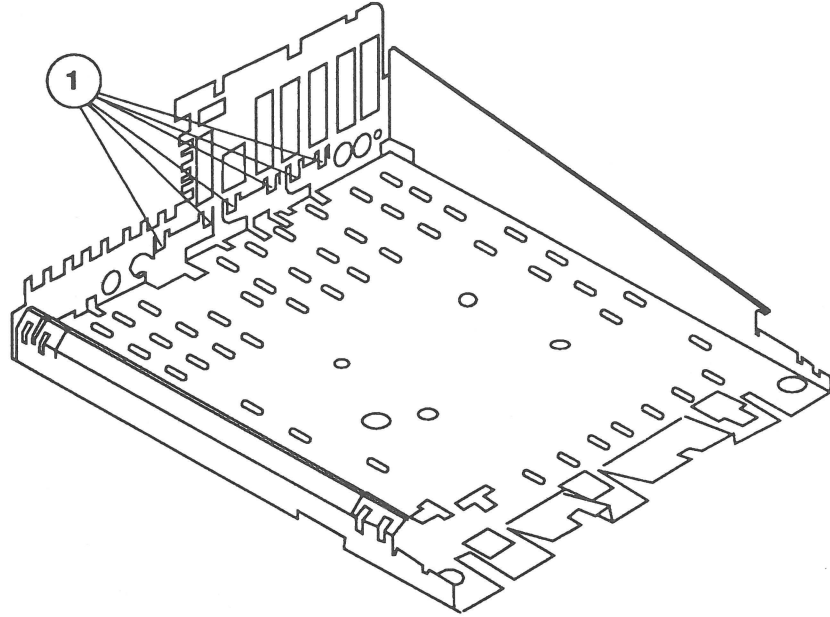

FIGURE 14

Apple IIGS

Section 6 – Upgrade for Apple IIe

☐ CONTENTS

6.2	Apple IIGS Upgrade for the Apple IIe
6.2	Introduction
6.2	Things to Remember
6.3	Materials Required
6.3	Installation Instructions
6.8	Apple IIe Extended Keyboard Modification

□ APPLE IIGS UPGRADE FOR THE APPLE IIe

Introduction

The Apple IIGS Upgrade Kit gives IIe owners a direct upgrade path to the Apple IIGS and all of its features. The kit includes the Apple IIGS logic board, a new bottom pan, and various bags of hardware. For more information on the Apple IIGS and its features, refer to the manual *From Apple IIe to Apple IIGS: Performance Update* or Section 1, Basics.

Things to Remember

1. Follow the electrostatic discharge precautions listed on the next page.
2. The kit contains a product label on the underside of the bottom pan that bears the UL and CSA marks. These marks are valid only if the Apple IIe that is being retrofitted is UL and CSA approved.

If the Apple IIe bottom pan does not carry the UL and CSA approvals, you must modify the product label on the retrofit bottom pan. Use an indelible black felt marker and block out the appropriate marking(s).

3. Before returning the system to the customer, run the *Apple 5.25 Inch Disk Drive Diagnostic* to verify that the system is functioning correctly. Refer to Section 3, Diagnostics.
4. If the customer's Apple IIe has a keyboard with a built-in keypad (Apple IIe Extended Keyboard), the keyboard must be modified in order to work correctly with the Apple IIGS. (The instructions are included in these procedures.)
5. Old Apple IIe cases made from structural foam will not fit correctly on the retrofit. To identify a structural foam case, remove the cover and look toward the back of the unit. If there are two oval plastic velcro pads, it is a foam case. Replace this case with the Apple IIe case and lid available from Apple.
6. Follow the return information included in the kit to ensure proper credit.

Materials Required

The following hardware is included in the kit:

- Bottom pan
- Apple IIGS logic board
- Keyboard support brackets
- Apple IIe shielding strip

The following will be in plastic bags labeled with the corresponding part numbers. The hardware shown below with an asterisk (*) may not be needed to perform the upgrade. Whether the hardware is needed will depend on the version of the Apple IIe system being upgraded.

- Nameplates (2) (607-5182)
- Power supply screws (4) (607-5176)*
- Bottom pan screws (9) (607-5177)*
- Logic board mounting screws (2) (607-5178)
- Keyboard and bracket mounting screws (8) (607-5179)*
- U-Nuts (9) (607-5180)*
- PCB Supports (9) (607-5181)

Note: The bag of screws labeled 607-5193 is for Canadian upgrades only.

The following tools are needed:

- ESD equipment
- Phillips head screwdriver
- Flat-head screwdriver
- Small flat-head screwdriver
- Small needlenose pliers

Installation Instructions

Before you begin, be sure to read the instructions on ESD prevention and all the information under "Things to Remember."

Keyboard Information

If the keyboard is mounted on the Apple IIe case, do not remove it. If the keyboard is mounted on brackets and not connected to the case, remove the keyboard.

If the customer has an Apple IIe extended keyboard, you will have to make a modification to the keyboard. Turn to "Apple IIe Extended Keyboard Modification" and perform the procedure now.

Case Information

Old Apple IIe cases made from structural foam will not fit correctly on the retrofit. To identify a structural foam case, remove the lid and look toward the back of the unit. If there are two oval plastic velcro pads (see Figure 1, #1), it is a foam case. Discard the case and replace it with a plastic case. The plastic case is available from Apple under the name "Apple IIe case and lid, beige."

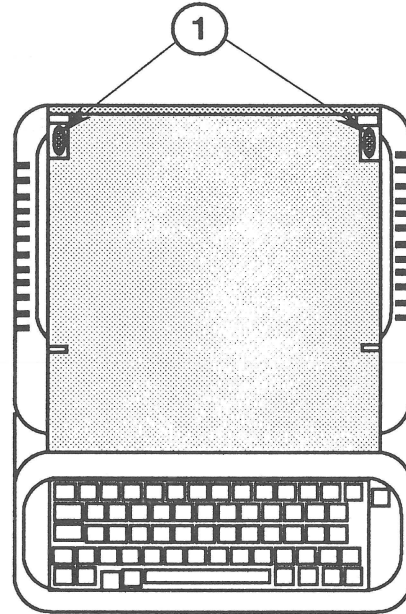

FIGURE 1

1. Remove the following from the customer's Apple IIe (if necessary, refer to *Apple IIe Technical Procedures*, Section 1, Take-Apart).

Top cover and housing
Power supply
Speaker
Keyboard

2. Install the nine PCB supports into the nine square holes on the new bottom pan.
3. Install the Apple IIGS logic board onto the PCB supports on the new bottom pan. Install the two logic board mounting screws (Figure 2, #1).
4. Install the customer's speaker on the new chassis (Figure 2, #2).
5. Connect the speaker cable to its plug on the logic board (Figure 2, #3).

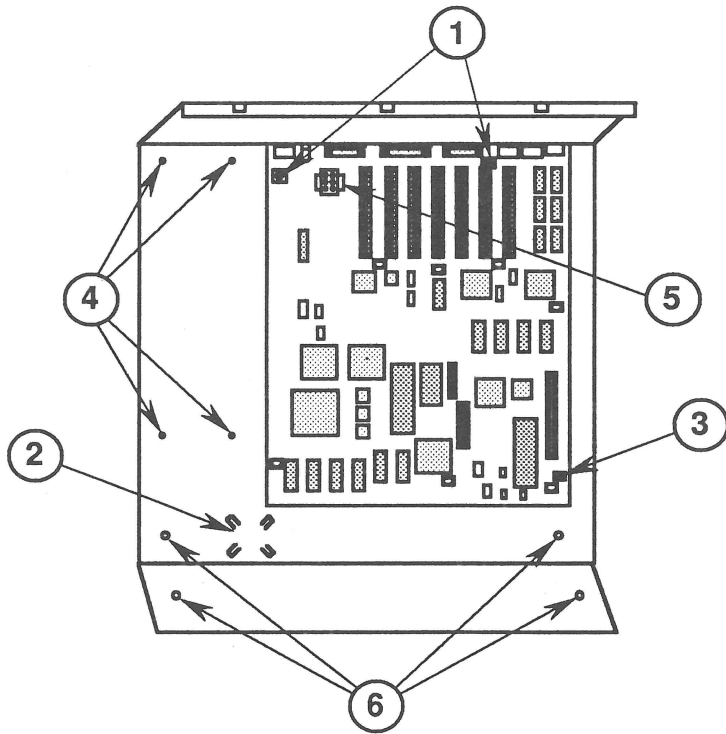

FIGURE 2

6. Align the screw mounts on the customer's power supply with the screw holes on the new bottom pan (Figure 2, #4). Insert and tighten the four power supply screws.
7. Connect the power supply connector to its socket on the logic board (Figure 2, #5).
8. Install the customer's keyboard.

If the keyboard is mounted on the case, skip to step 11.

If the keyboard is mounted on brackets, continue to step 9.

9. Using four of the screws, install the brackets (one on each side) on the bottom pan (Figure 2, #6).

10. Position the keyboard on the brackets and insert the four remaining screws.

You may need to adjust the position of the keyboard when installing the case to ensure an even gap between the keyboard and case.

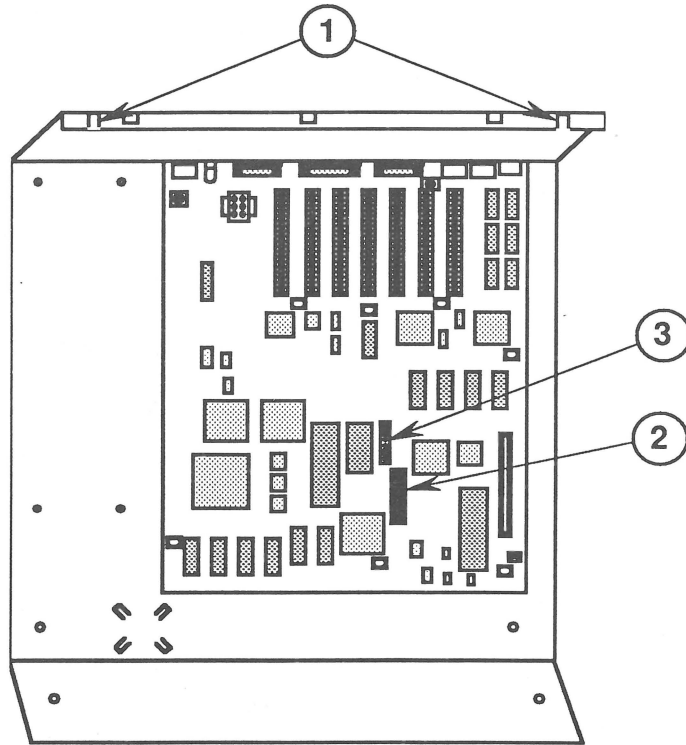

FIGURE 3

11. Install the shielding strip on the rear of the bottom pan between the two notches (Figure 3, #1). Figure 4, shows a side view of the shielding strip (Figure 4, #2). being slid onto the rear lip of the bottom pan (Figure 4, #2).

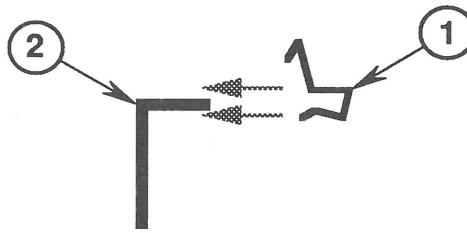

FIGURE 4

12. Check the plastic case to ensure that it has u-nuts installed on all the screw holes. If u-nuts are not installed, refer to Figure 5, which is a side view of one hole (Figure 5, #1) with the u-nut being slipped into position (Figure 5, #2).

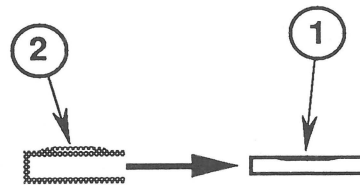

FIGURE 5

13. Remove the two old nameplates on the lid by inserting a small flat-blade screwdriver into the hole in the lid underneath the nameplates. Install the new ones, and destroy the old ones.
14. Position the customer's case on the new chassis.
15. Connect the keyboard cable to its socket on the logic board (Figure 3, #2).
16. Insert and tighten the screws to hold the case in place.

Note: If the customer has an Apple IIe Numeric Keypad, plug it into the connector shown in Figure 3, #3.

17. Run the functional test on the system to verify that it is working correctly. (Refer to Section 3, Diagnostics.)
18. Return the appropriate items to Apple. Follow the instructions included in the kit.

Apple IIe Extended Keyboard Modification

There are two keyboards available that have built-in keypads. In order for either of the keyboards to work correctly with the Apple IIGS logic board, two jumper pads may need to be cut (or unsoldered depending on the style of the jumper pads) and two jumper pads need to be soldered.

Keyboard Identification

The solder pads are located in different areas on the two keyboards. Identify the keyboards as Mitsumi or TCI. The Mitsumi keyboard has the name *Mitsumi* in the lower-left corner of the back of the keyboard.

Solder Pads

Identify the type of solder pads used on the keyboard. There are two types of solder pads used. Some keyboards use the solder pad that needs to be cut and soldered (Figure 6-A). Some keyboards use only the type that needs to be soldered or unsoldered (Figure 6-B); no cutting of the solder pads needs to be done.

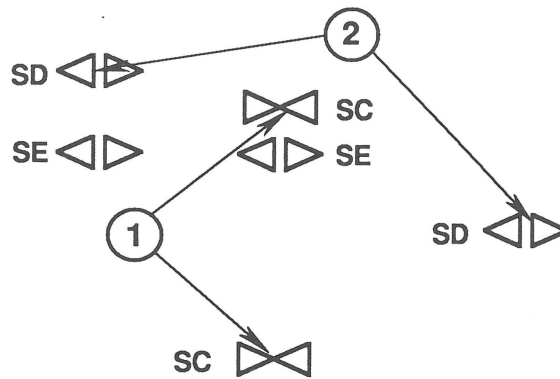

FIGURE 6A

Keyboard Figures

In Figures 6-A and 6-B, Version A represents the Mitsumi keyboard, and Version B represents the TCI keyboard. Refer to the appropriate figure and labeled version when performing the procedures.

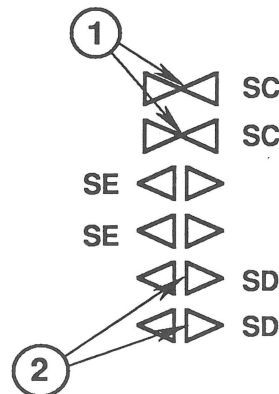

FIGURE 6B

Materials Required

Keyboard with built-in keypad to be modified
Exacto knife
Soldering materials
Digital ohmmeter

CAUTION: *When cutting the two jumper pads, be extremely careful that you cut no other traces.*

Instructions

1. Turn the keyboard so that the trace side is up and the cable connector is at the top. The jumper pads are located under the cable connector on the circuit board.
2. Locate the two jumper pads marked SC (Figure 6, #1). Using the exacto knife, separate the two jumper pads, one pair at a time, by cutting the junction at the location indicated in Figure 7, #1.

FIGURE 7

If you are using the keyboard that uses the solder pads shown in Figure 8, desolder the jumper pads and continue with the procedure.

FIGURE 8

3. Use the ohmmeter to verify that the two jumper pads marked SC are not touching.
4. Locate the two jumper pads marked SD (Figure 6, #2). Apply a little bit of solder to the iron. Then, with the tip touching the jumper pads, one pair of pads at a time, apply the new solder to the location indicated in Figure 8, #1.
5. Use the ohmmeter to verify that both SD jumper pads are now connected.

Apple IIGS

Illustrated Parts List

□ CONTENTS

- IPL.3 Main Assembly (Figure 1)
- IPL.5 Base Assembly (Figure 2)
- IPL.7 Keyboard (Figure 3)
- IPL.9 Mouse (Figure 4)
- IPL.11 Cables (Figure 5)
- IPL.13 Upgrade (Figure 6)

The figures and lists in this section include all piece parts that can be purchased separately from Apple for the Apple IIGS, along with their part numbers. These are the only parts available from Apple. Refer to your *Apple Service Programs* manual for prices.

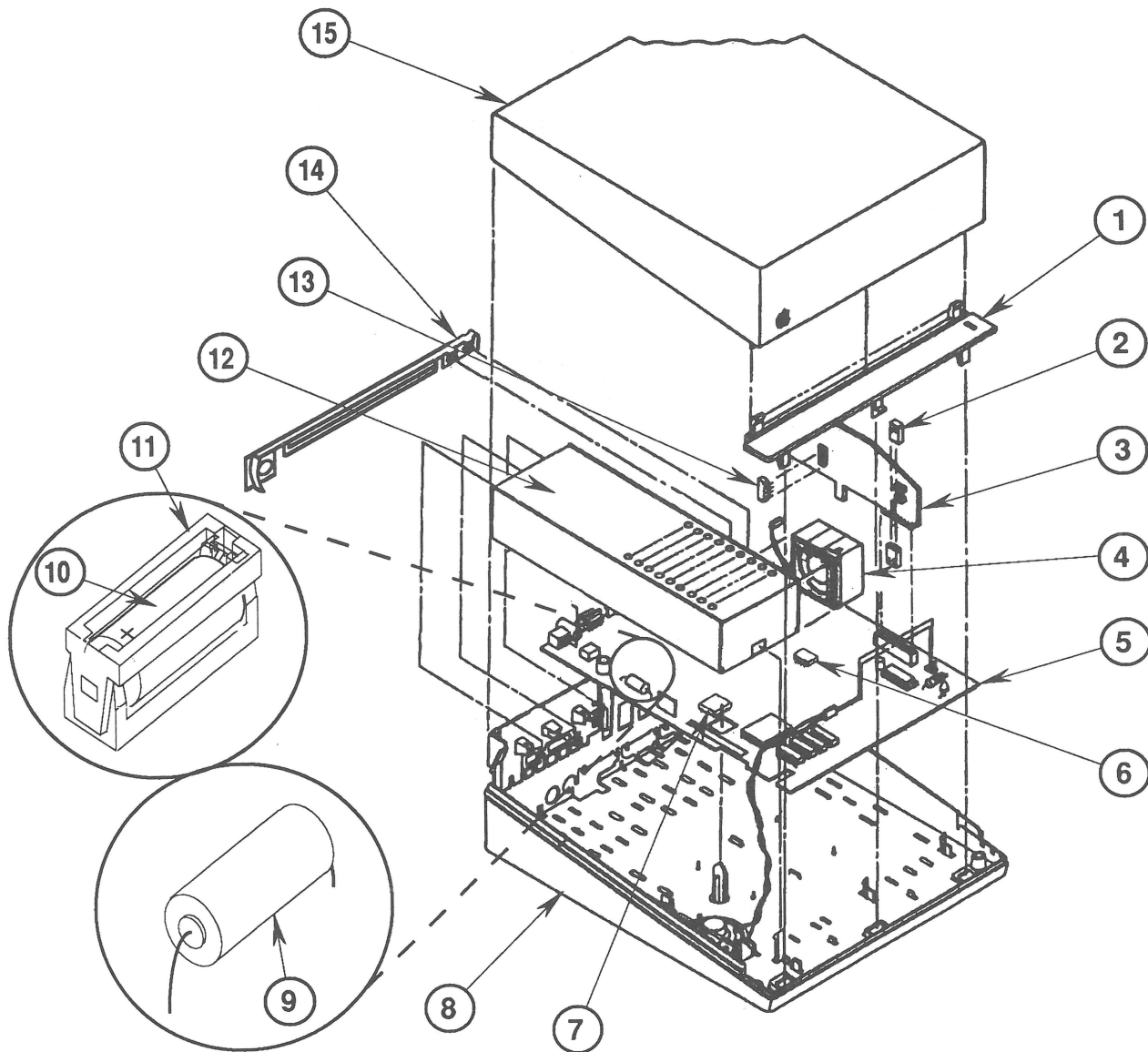

FIGURE 1

□ **APPLE IIGS—MAIN ASSEMBLY (Figure 1)**

<u>Item</u>	<u>Part No.</u>	<u>Description</u>
1	607-5006	Case Hinge
2	517-1230	RAM Expansion Card Jumper*
3	661-0336	Memory Expansion Card
4	607-5007	Fan
5	661-0334	Logic Board, Apple IIGs
	661-0515	Logic Board, Apple IIGs, 1 MB
6	342-0077	IC, 1 MB ROM
7	344S0046	IC, VGC
8	607-5005	Base
9	742-0009	Lithium Battery (with leads)
10	742-0011	Lithium Battery (without leads)
11	520-0344	Battery Holder Cover
12	661-0335	Power Supply
13	334-0021	RAM, 256K
14	805-0169	EMI Fence
15	607-5004	Top Cover

*Also used on the Apple IIGs, 1 MB Logic Board

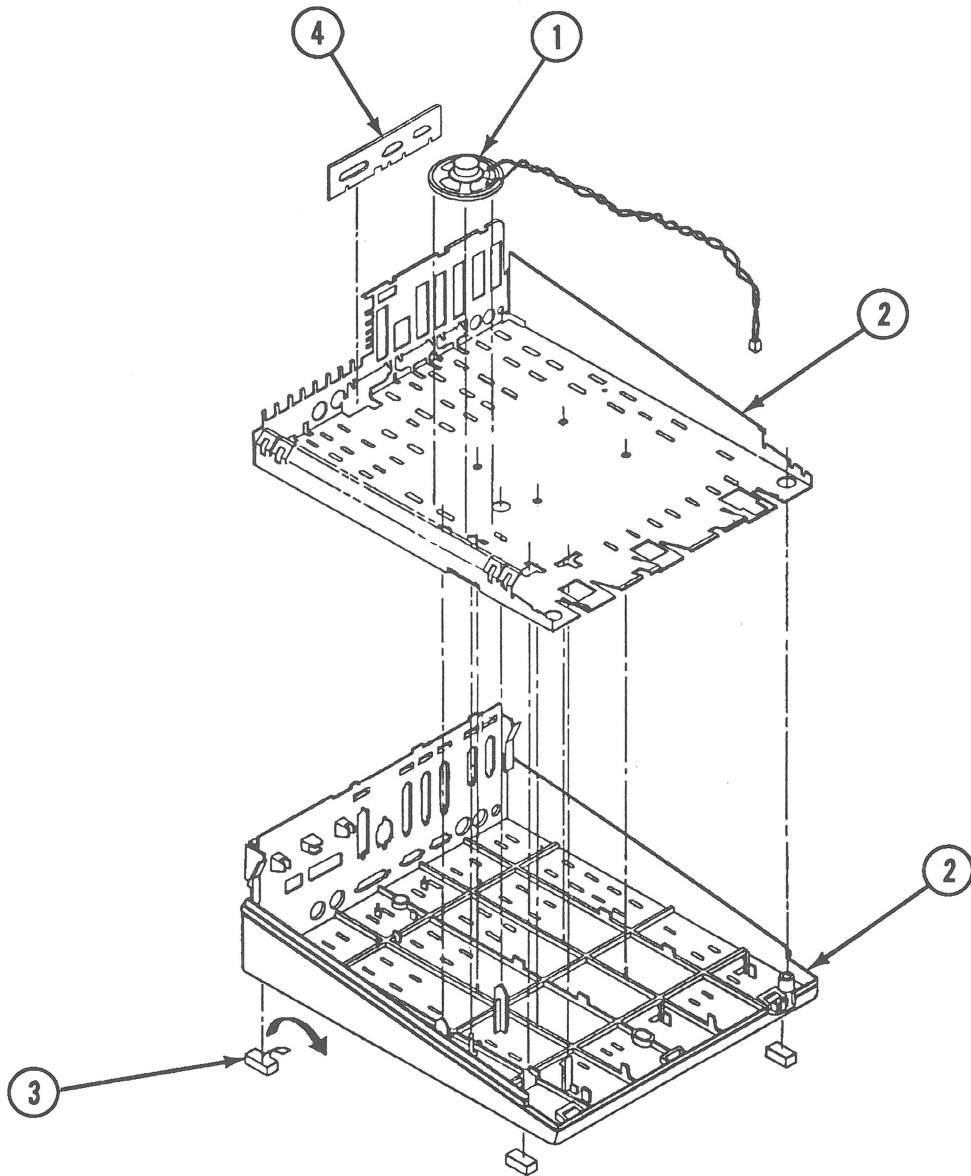

FIGURE 2

□ APPLE IIGS – BASE ASSEMBLY (Figure 2)

<u>Item</u>	<u>Part No.</u>	<u>Description</u>
1	607-5174	Speaker
2	607-5005	Base
3	865-0024	Foot
4	944-1189	Thin EMI Foam

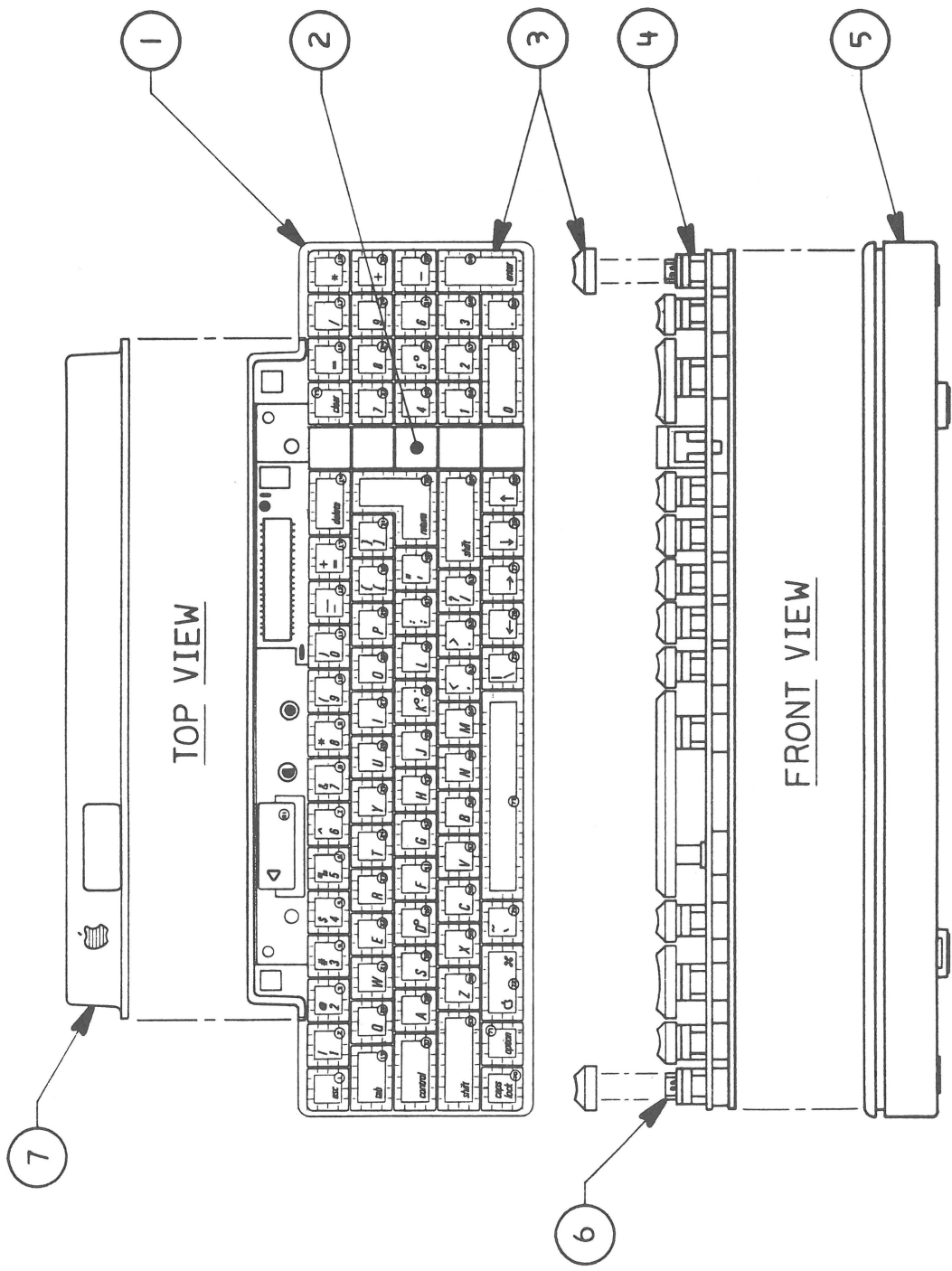

FIGURE 3

□ **APPLE IIgs – KEYBOARD (Figure 3)**

<u>Item</u>	<u>Part No.</u>	<u>Description</u>
1	661-0337	Apple DeskTop Bus Keyboard
2	815-0418	Keypad Spacer Case, ADB Keyboard
3	658-7093	Keycap Set, ADB Keyboard
4	076-0209	Keyswitch Set, ADB Keyboard
5	815-0416	Case Bottom, ADB Keyboard
6	970-1263	Alps Locking Keyswitch
7	815-0417	Case Top, ADB Keyboard

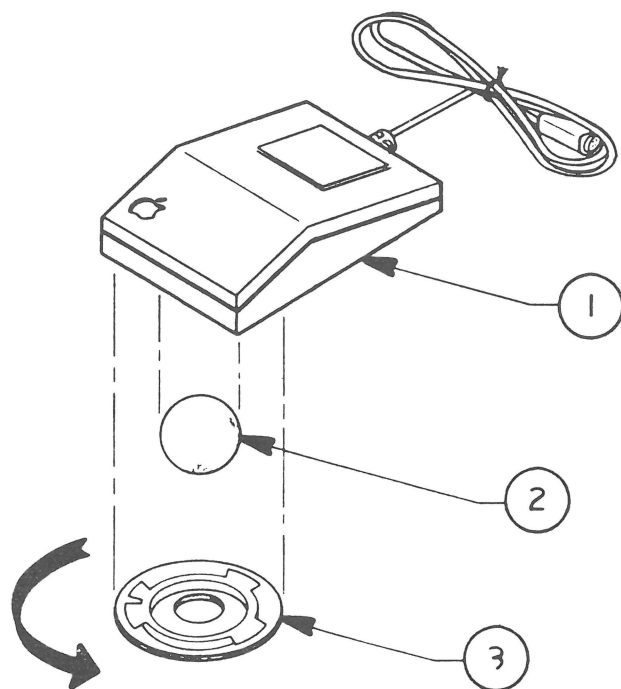

FIGURE 4

□ **MOUSE (Figure 4)**

<u>Item</u>	<u>Part No.</u>	<u>Description</u>
1	661-0338	Apple DeskTop Bus Mouse
	661-0479	ADB Mouse (replacing part number 661-0338)
2	699-8001	Mouse Ball (25.4mm dia)
	699-8038	Mouse Ball (21.9mm dia)
	815-1135	Mouse Ball (for part number 661-0479)
3	076-0231	Retainer, ADB Mouse (38mm dia)
	815-0816	Retainer, ADB Mouse (34mm dia)
	815-1136	Retainer, ADB Mouse (for part number 661-0479)

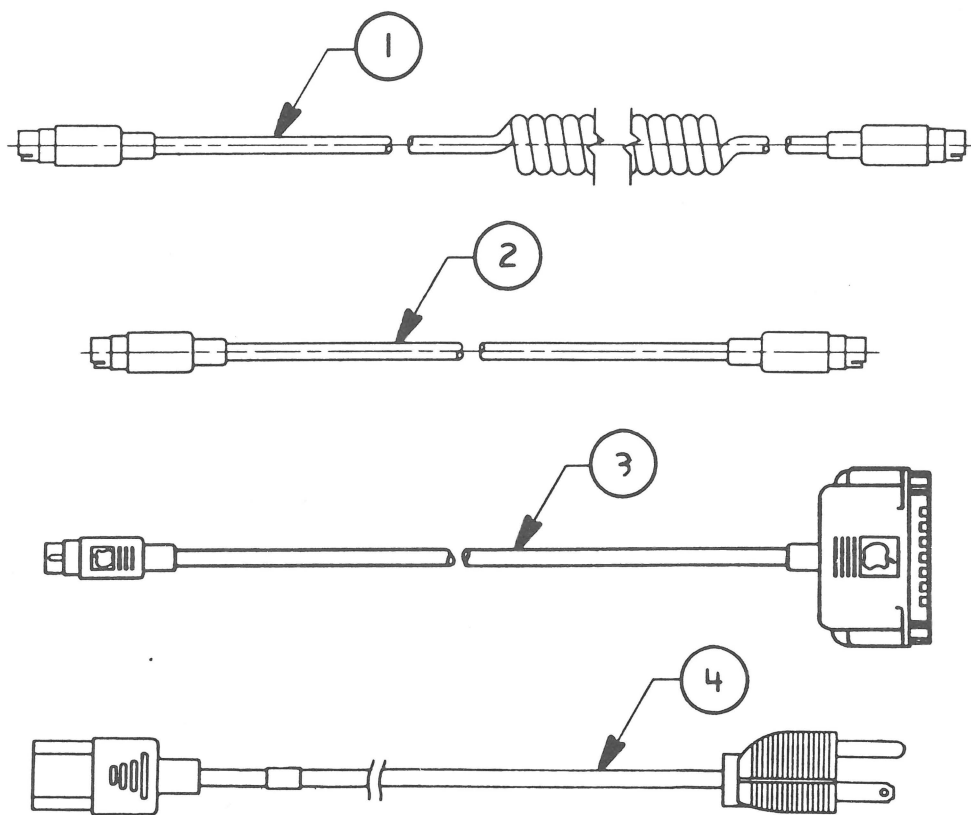

FIGURE 5

□ **APPLE IIgs – CABLES (Figure 5)**

<u>Item</u>	<u>Part No.</u>	<u>Description</u>
1	590-0361	ADB Keyboard Cable
2	590-0109	ADB Cable
3	590-0550	Peripheral Adapter Cable, Apple IIgs
4	590-0380	AC Power Cable, Platinum

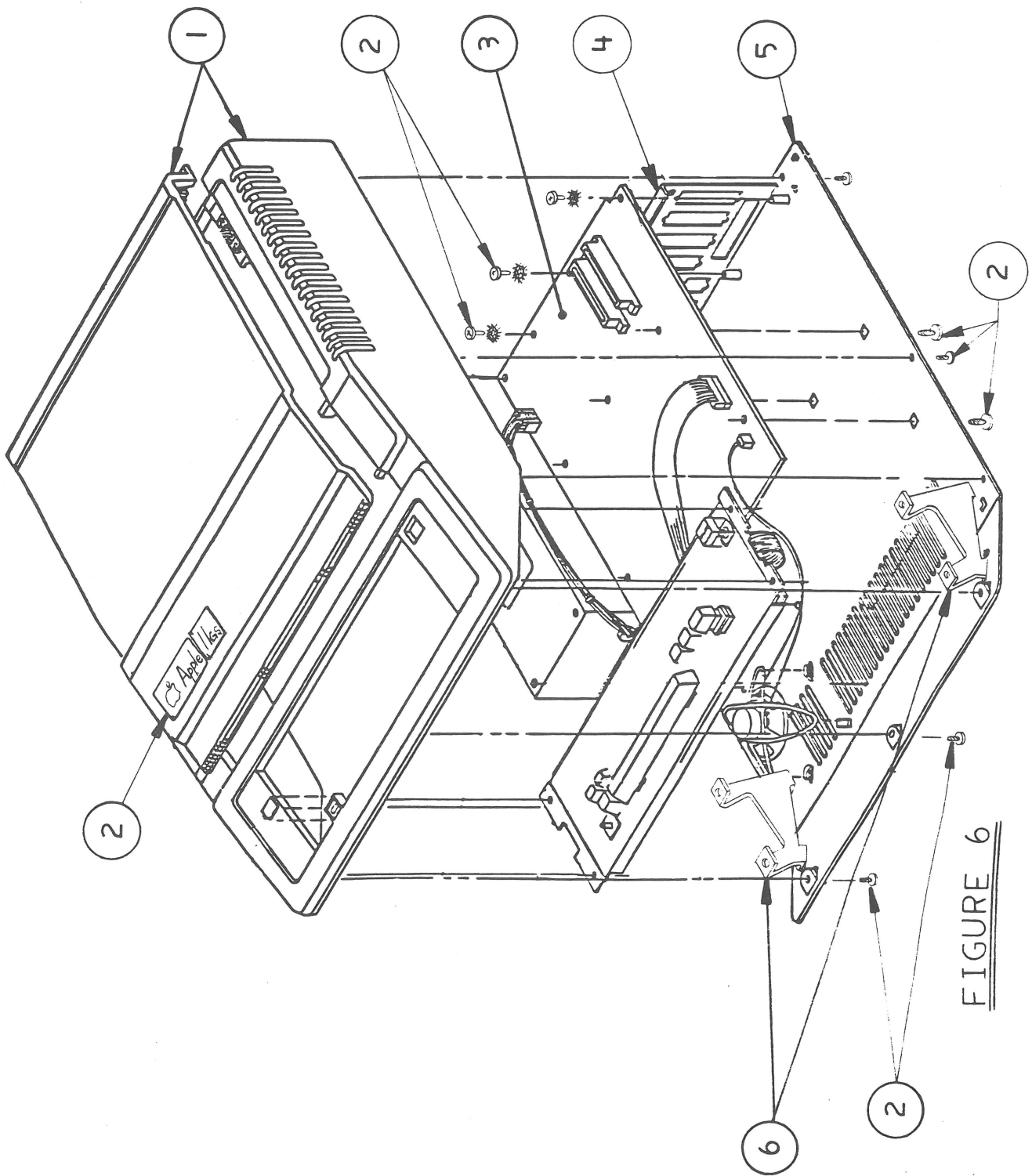

FIGURE 6

□ **APPLE IIGS – UPGRADE (Figure 6)**

<u>Item</u>	<u>Part No.</u>	<u>Description</u>
1	076-0127	Apple Iie Case and Lid, Beige
2	607-5183	Assembly Hardware Package
3	661-0679	Logic Board, Upgrade from Apple Iie to Apple IIGS
4	875-0063	Shielding Strip
5	607-5012	Bottom Pan, Apple IIGS Upgrade
6	805-0168	Bracket, Apple IIGS Upgrade Keyboard

Apple IIc Plus

Technical Procedures

□ TABLE OF CONTENTS

Section 1 – Basics	1.2	Product Description
	1.2	Specifications
	1.3	Interface Ports and Connectors
	1.5	Theory of Operation
	1.5	Introduction
	1.6	Logic Board
	1.7	Power Supply
	1.7	Disk Drive
	1.7	Keyboard
Section 2 – Take-Apart	2.2	Top Case
	2.4	Keyboard
	2.6	Disk Drive
	2.9	Eject Button
	2.11	Power Supply
	2.12	Logic Board
	2.15	Speaker
Section 3 – Diagnostics	3.2	Introduction
	3.2	Things to Remember
	3.2	Before You Begin
	3.2	Setting Up
	3.3	While Testing
	3.4	Built-In Diagnostic
	3.4	Running the Diagnostic
	3.4	Results
	3.5	Apple IIc Plus Diagnostic
	3.5	Main Menu
	3.6	Choose Tests
	3.8	Options
	3.9	Special
3.9	Running the Diagnostics	
3.13	Test Failures	

**Section 4 –
Troubleshooting**

- 4.2 Introduction
- 4.2 General Information
- 4.2 How to Use the Symptom Charts
- 4.3 Symptom Charts
- 4.3 Video Problems
- 4.3 Drive Problems
- 4.4 Peripheral Problems
- 4.4 Miscellaneous Problems

**Illustrated
Parts List**

- IPL.3 Finished-Goods Assembly (Figure 1)

©Apple Computer, Inc., 1988 and 1989. No portion of this document may be reproduced in any form without the written permission of Apple Computer, Inc.

AppleColor, AppleMouse, and UniDisk are trademarks of Apple Computer, Inc.

ProDOS, Apple, and the Apple logo are registered trademarks of Apple Computer, Inc.

Apple IIc Plus

Section 1 – Basics

□ CONTENTS

1.2	Product Description
1.2	Specifications
1.3	Interface Ports and Connectors
1.5	Theory of Operation
1.5	Introduction
1.6	Logic Board
1.7	Power Supply
1.7	Disk Drive
1.7	Keyboard

□ PRODUCT DESCRIPTION

The newest member of the Apple IIc family, the IIc Plus, sports a 3.5-inch 800K internal disk drive replacing the original 5.25-inch 140K drive, and a faster 65C02 microprocessor operating at up to 4 MHz. The keyboard has also been changed to match the keyboard of the Apple IIgs.

Specifications

The specifications that follow are identical to those for the original Apple IIc in many respects. Any items that are different are printed in *italics*.

Central Processing Unit (CPU)

- *65C02 operating at up to 4 MHz*
- 8-bit data bus
- 16-bit address bus

Memory

- 128K RAM, expandable through the memory expansion connector

Note: The Apple IIc Memory Expansion Card is **not** compatible with the IIc Plus. Compatible memory cards can be purchased from third-party manufacturers.

- 32K ROM

Video

- 40-column x 24-line text mode
- 80-column x 24-line text mode
- Low-resolution graphics (40 x 48)
- High-resolution graphics (80 x 192)
- Double high-resolution graphics (560 x 192)
- 96 ASCII characters, including upper and lower case; 32 graphics characters (Mousetext)
- NTSC-compatible composite output
- Video expansion port supports an optional RF modulator or Flat Panel Display

Mass Storage

- *3.5-inch 800K internal disk drive*
- UniDisk™, Apple 5.25 Drive, UniDisk 3.5, Apple 3.5 Drive, or Disk IIc external drives (optional)

Input/Output

- Built-in speaker
- Hand Controller/Joystick/Mouse port
- 2 RS-232 serial ports
- External video port
- External disk drive port
- Composite video connector

Keyboard

- 63 keys
- 128-character ASCII set, including 32 control characters
- DVORAK or Sholes standard layout, switch selectable

Indicators

- Power
- Disk activity

Interface Ports and Connectors

Specific interface port pin-outs, signal descriptions, and connector information can be found in the *Peripheral Interface Guide*.

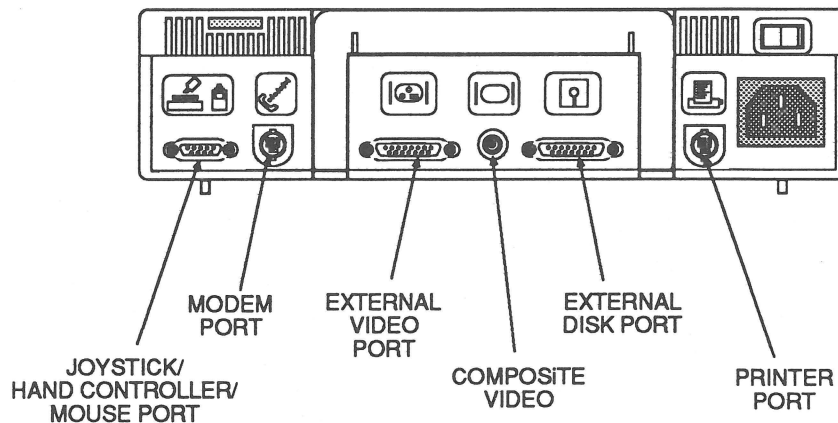

FIGURE 1

- **Joystick/Hand Controller/Mouse Port**
Supports Mouse IIc, Joystick IIc, Hand Controllers IIc
- **Modem Port**
RS-232 serial
50 to 19.2K baud
5, 6, 7, or 8 data bits
1 or 2 stop bits
Odd, Even, or No Parity
Mini DIN-8 connector
- **External Video Port**
RF modulator support
Flat Panel Display (optional)
RGB output
- **Composite Video Connector**
NTSC composite—monochrome and color
- **External Disk Port**
Supports the UniDisk™, Apple 5.25 Drive, UniDisk 3.5, Apple 3.5 Drive, and Disk IIc
- **Printer Port**
Identical to modem port (see above)

□ THEORY OF OPERATION

Introduction

Troubleshooting can be approached in many different ways. Apple recommends two methods in particular:

- Logical troubleshooting
- Module swapping in a particular order for a particular symptom

Most troubleshooting charts in the *Apple Service Technical Procedures* are based upon the module-swapping method, but you can often save repair time by using logical troubleshooting before you start swapping.

Logical troubleshooting involves knowing the function of each module in the machine, and using that information to narrow your search for the problem. This section will provide you with the information necessary to perform logical troubleshooting of the Apple IIc Plus. The information here includes a description of each module in the IIc Plus and the various functions it performs. (For definitions of basic terms refer to Simplified Overview of a Microcomputer System under the tab *You Oughta Know*.)

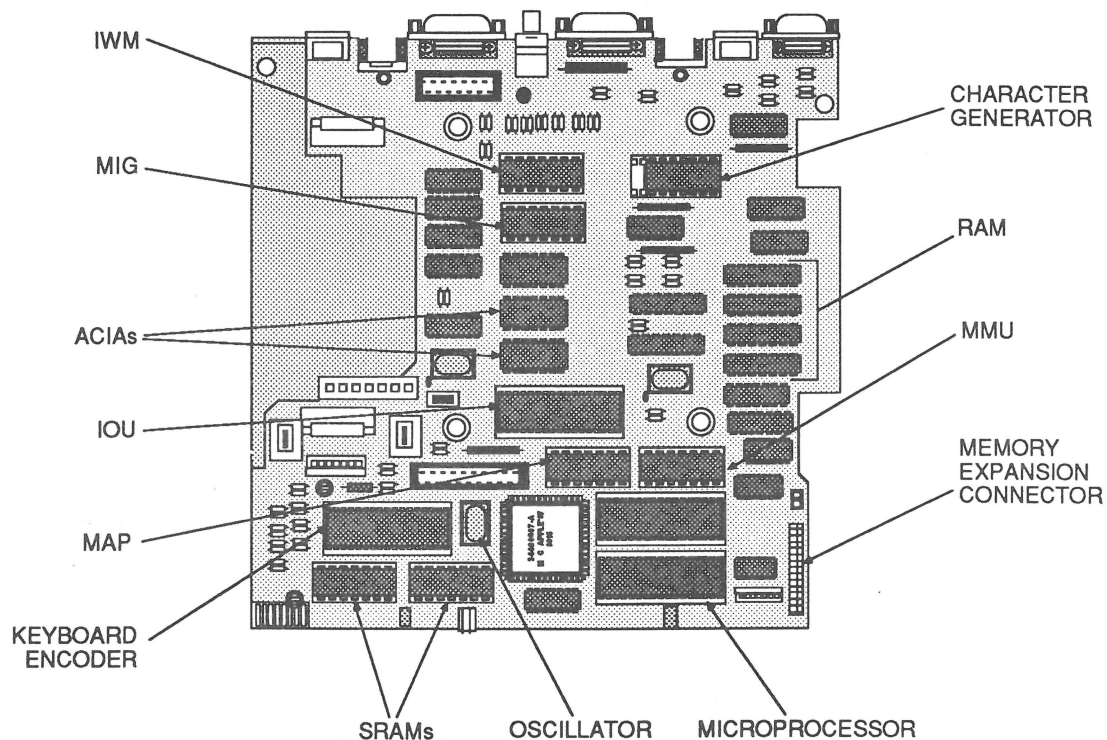

FIGURE 2

Logic Board

The logic board (Figure 2) is the heart of the system. It contains the components described below.

- The **Central Processing Unit** (CPU), an enhanced 65C02 microprocessor, gets instructions from memory, translates them, and carries them out. The CPU communicates with all components on the logic board.
- An **Application-Specific Integrated Circuit** (ASIC) implements a custom accelerator circuit supporting both 1.024- and 4-MHz operation.
- Four **64K x 4-bit Dynamic RAMs** (DRAMs) provide 128K of read/write memory to store programs and data on a temporary basis.
- Two **8K x 8-bit Static RAMs** (SRAMs) provide a data cache for the accelerator circuit.
- **32K of Read-Only Memory** (ROM) contains the Applesoft BASIC language, machine language monitor, and the enhanced video firmware.
- The **Memory Management Unit** (MMU) contains most of the logic that controls memory addressing.
- The **Input/Output Unit** (IOU) contains most of the logic that controls the built-in input and output ports.
- The **Multidrive Interface Glue** (MIG) chip provides a RAM cache and hardware interface for the 3.5-inch disk drive.
- The **Integrated Woz Machine** (IWM) is a self-contained disk controller card on a single integrated circuit. This IC supports both 3.5- and 5.25-inch disk drives.
- Two **6551 Asynchronous Communication Interface Adapters** (ACIA) handle the information to be sent and received through the two built-in serial ports.
- The **3600-PRO Keyboard Encoder** interprets data sent from the keyboard when a key is pressed.

- The **Oscillator** generates the master clock pulse. This master pulse is sent to two custom components, which break down the clock pulse and send it to various ICs on the logic board.
- The **Character Generator** provides the bit patterns for characters to be displayed.
- A **Memory Expansion Connector** allows you to add an optional third-party memory card.

Power Supply

The power supply generates the +5, +12, and -12 volts DC needed by the system.

Disk Drive

The disk drive provides 800K of permanent storage for the system. The drive connects to the logic board through a flat ribbon cable. The flow of data between the logic board and the disk drive is channeled through the IWM disk controller, which controls reading and writing operations.

Keyboard

The keyboard is a matrix of keyswitches connected to the logic board via a ribbon (flat) cable. The 3600-PRO keyboard encoder IC on the logic board translates the information from the keyboard into signals that the logic board can use.

Apple IIc Plus

Section 2 – Take-Apart

☐ CONTENTS

2.2	Top Case
2.4	Keyboard
2.6	Disk Drive
2.9	Eject Button
2.11	Power Supply
2.12	Logic Board
2.15	Speaker

Note: If a step is underlined, detailed instructions for that step can be found elsewhere in this section.

□ TOP CASE

Materials Required

#1 Phillips screwdriver

Remove

1. Turn off the computer and disconnect all cables from the back of the computer, if necessary.
2. **Carefully** place the computer upside-down on a **padded** work surface.

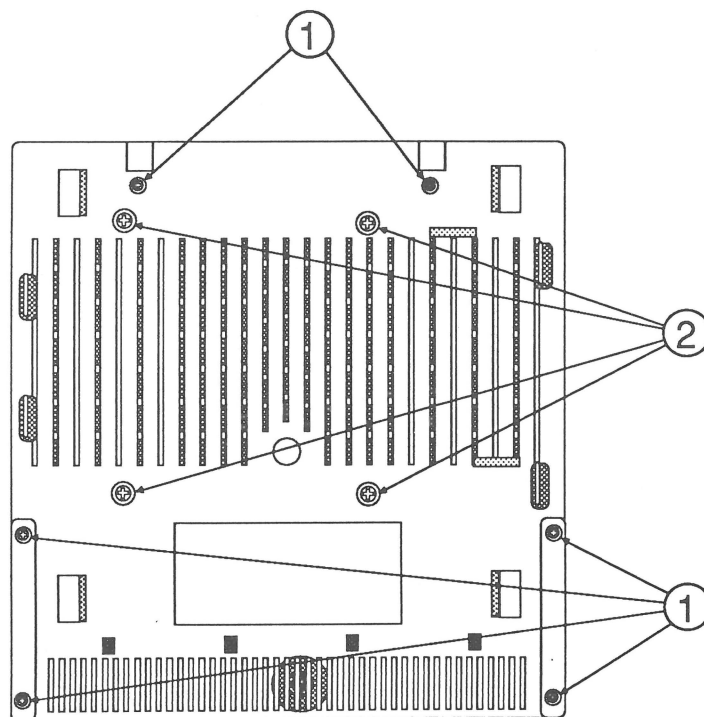

FIGURE 1

3. Remove the six Phillips screws (Figure 1, #1) that secure the top case to the bottom case.
4. **If you are replacing the disk drive, logic board, or eject button,** remove the four Phillips screws (Figure 1, #2) that secure the disk drive to the bottom case.
5. Turn the computer over and place it on the work surface.

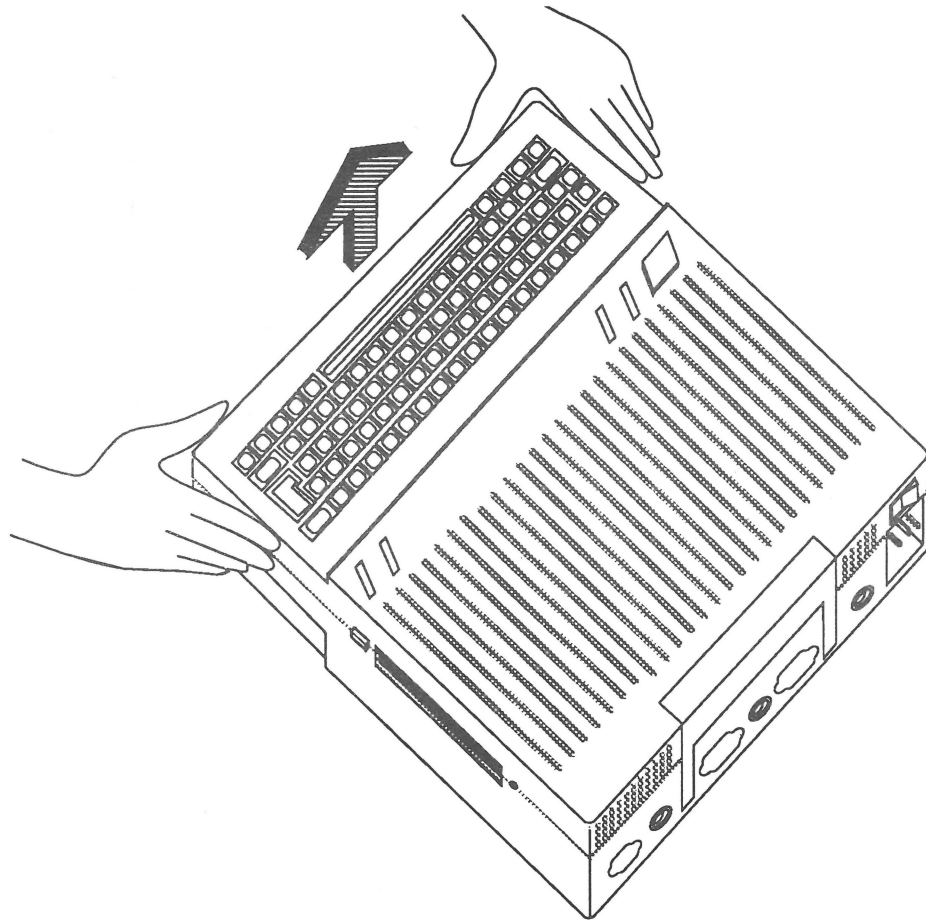

FIGURE 2

6. Place each thumb on the front of the top case (approximately one-third of the distance in from the edge) and your index fingers on the side of the bottom case near the upper-right and -left corners of the keyboard (Figure 2). Simultaneously press the top case back and up until the front of the top case comes loose.
7. Pivot the top case up and remove it toward the rear of the computer.
8. Remove the handle and lay it aside.

Replace

1. If the handle is not already in place in the top case, place the handle in its slots in the bottom case.
2. Place the top case in position so that the bottom edge of the rear panel mates with the rear edge of the bottom case.

3. Lower the front of the top case and press down until the case "clicks" into place. Carefully turn over the computer and place it on the work surface.
4. **If you removed the disk drive screws,** replace them.
5. Replace the six top case screws.

□ KEYBOARD

Materials Required

None

Remove

1. Remove the top case.

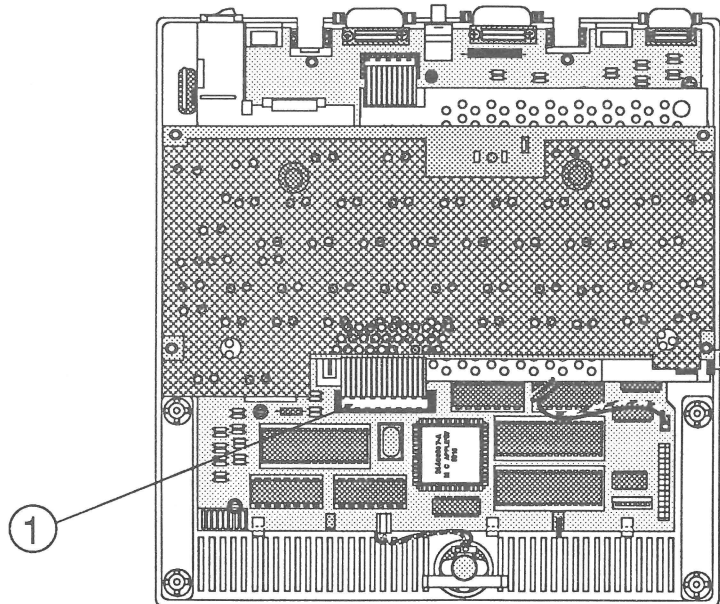

FIGURE 3

2. Lift the keyboard up and disconnect the keyboard cable from logic board connector J9 (Figure 3, #1).

Replace

1. Connect the keyboard cable to logic board connector J9.

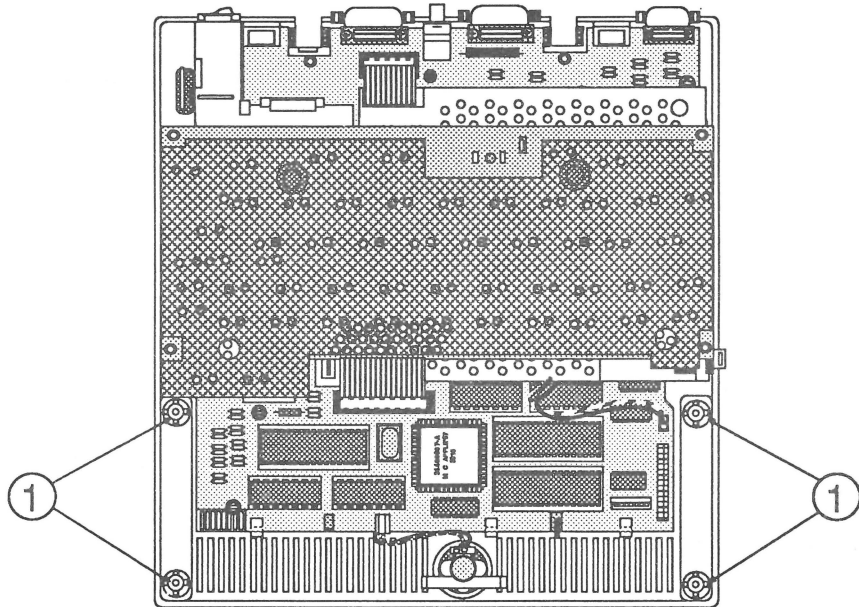

FIGURE 4

2. Place the keyboard in position on its four support posts (Figure 4, #1).
3. Replace the top case.

□ DISK DRIVE

Materials Required

#2 Phillips screwdriver

Remove

1. Remove the top case, including the four disk drive screws.

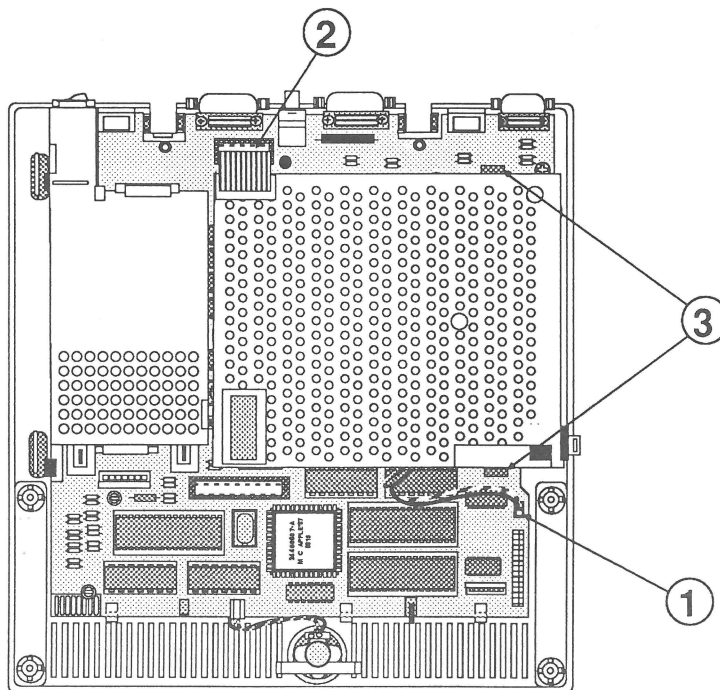

FIGURE 5

2. Lift the keyboard up and forward, and disconnect the eject button cable from logic board connector J7 (Figure 5, #1).
3. Disconnect the disk drive cable from logic board connector J8 (Figure 5, #2).
4. Lift the disk drive straight up and out of the computer.
5. Remove the two Phillips screws (Figure 5, #3), one on each side of the drive shield.
6. While simultaneously pulling each side of the upper drive shield away from the lower drive shield, lift the upper drive shield. You'll need to pull the sides away far enough to disengage the retaining pins (located next to the shield screws).

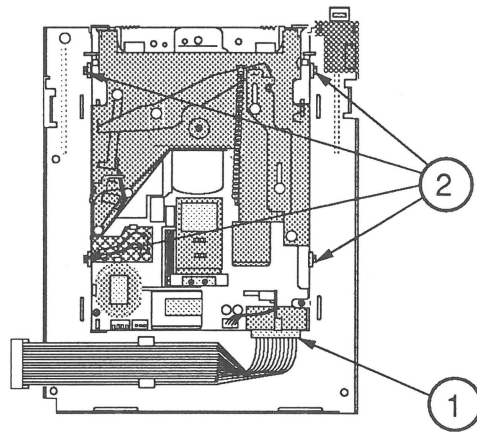

FIGURE 6

7. Disconnect the disk drive cable (Figure 6, #1) from the disk drive.
8. Remove the four Phillips screws (Figure 6, #2) holding the disk drive mechanism to the lower drive shield, and remove the disk drive.

Note: If you are sending the disk drive mechanism to Apple, place it in the shipping fixture that the replacement drive mechanism came in, and install a plastic shipping disk into the drive.

Replace

1. Remove the shipping fixture and the plastic shipping disk from the replacement disk drive mechanism.
2. Place the disk drive mechanism in position in the lower drive shield, and replace the four Phillips screws.
3. Attach the disk drive cable to the disk drive.
4. Place the upper drive shield on the lower drive shield, making sure that the tabs at the rear of the upper shield engage in the slots in the lower shield. Press down the front of the upper shield until the retaining pins engage.
5. Replace the two Phillips screws holding the upper shield to the lower shield.

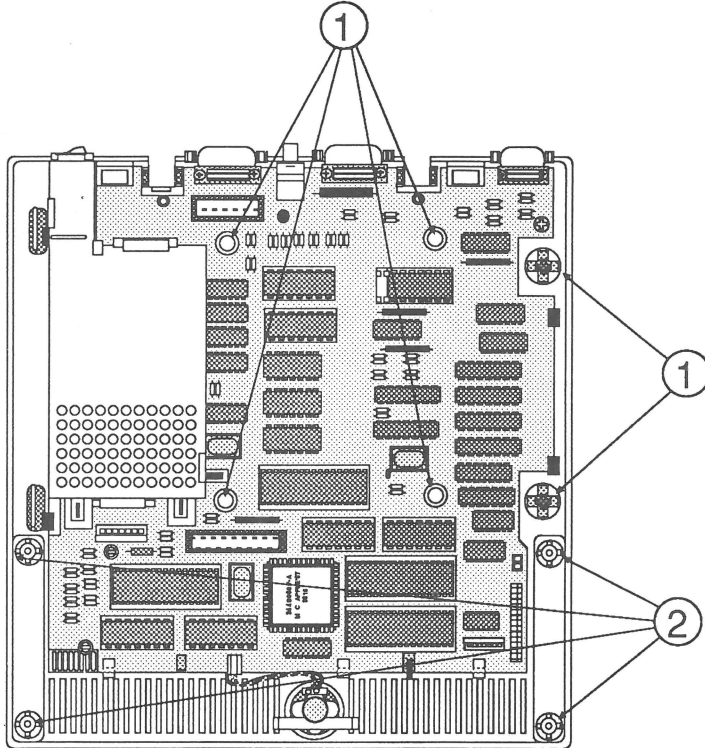

FIGURE 7

6. Place the disk drive in position on its six support posts (Figure 7, #1).
7. Connect the disk drive cable to logic board connector J8.
8. Connect the eject button cable to logic board connector J7.
9. Place the keyboard in position on its four support posts (Figure 7, #2).
10. Replace the top case.

□ EJECT BUTTON

Materials Required

#1 Phillips screwdriver

Remove

1. Remove the top cover and disk drive.

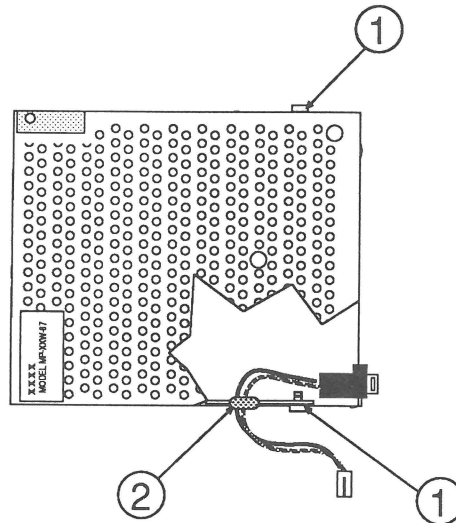

FIGURE 8

2. Remove the two Phillips screws (Figure 8, #1) that secure the disk drive top shield to the bottom shield.
3. Lift the front of the top shield and simultaneously pull the shield forward to disengage the tabs at the rear.
4. Remove the eject button wires and grommet (Figure 8, #2) from the bottom shield.
5. Remove the eject button by pulling the middle tab slightly forward and simultaneously lifting the switch from its post.

Replace

1. Slide the eject button switch onto its post until you hear a click.
2. Slide the wire grommet into its slot in the lower shield.
3. Place the tabs at the rear of the top shield into their respective slots in the bottom shield.
4. Replace the two top shield screws.
5. Replace the disk drive and top cover.

□ POWER SUPPLY

Materials Required

None

Remove

1. Remove the top case and keyboard.

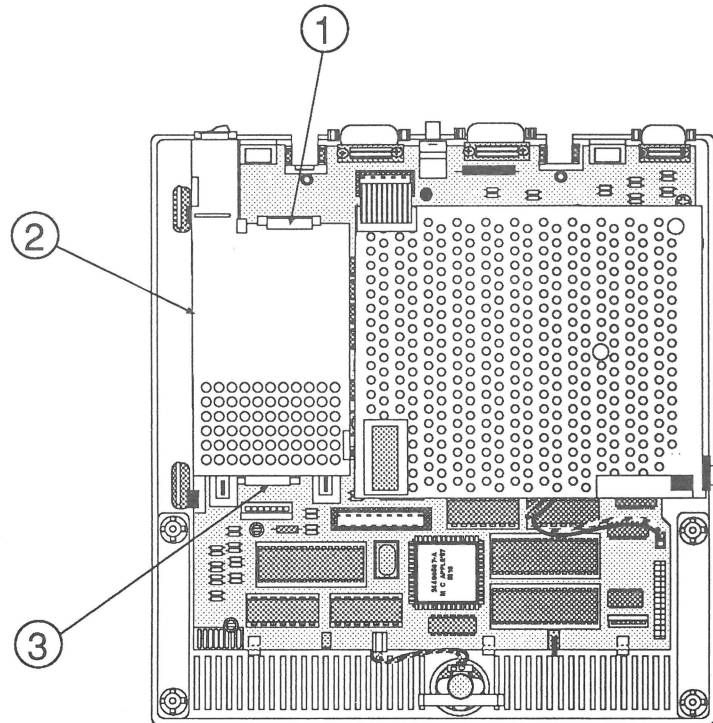

FIGURE 9

2. Simultaneously pull back on the rear power supply latch (Figure 9, #1) and lift the rear of the power supply (Figure 9, #2) far enough to disengage the latch.
3. While still holding up the rear of the power supply, simultaneously pull forward on the front power supply latch (Figure 9, #3) and lift the front of the power supply far enough to disengage logic board connector J1.

Replace

1. Place the power supply in position on logic board connector J1 and press down until the front and rear power supply latches engage in their respective openings in the power supply.

CAUTION: *Be careful when reinstalling the power supply, or you could damage the connector.*

2. Replace the keyboard and top case.

LOGIC BOARD

Materials Required

- #1 Phillips screwdriver

Remove

1. Remove the top case, keyboard, disk drive, and power supply.

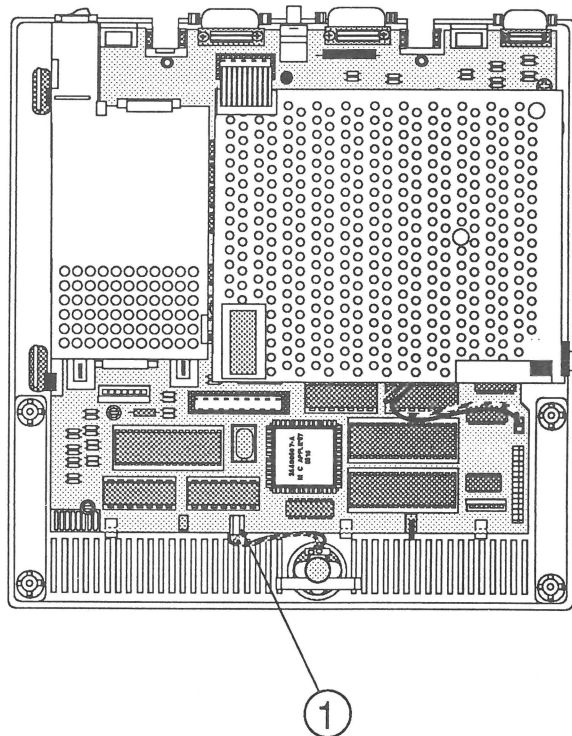

FIGURE 10

2. Disconnect the speaker cable from logic board connector J10 (Figure 10, #1).

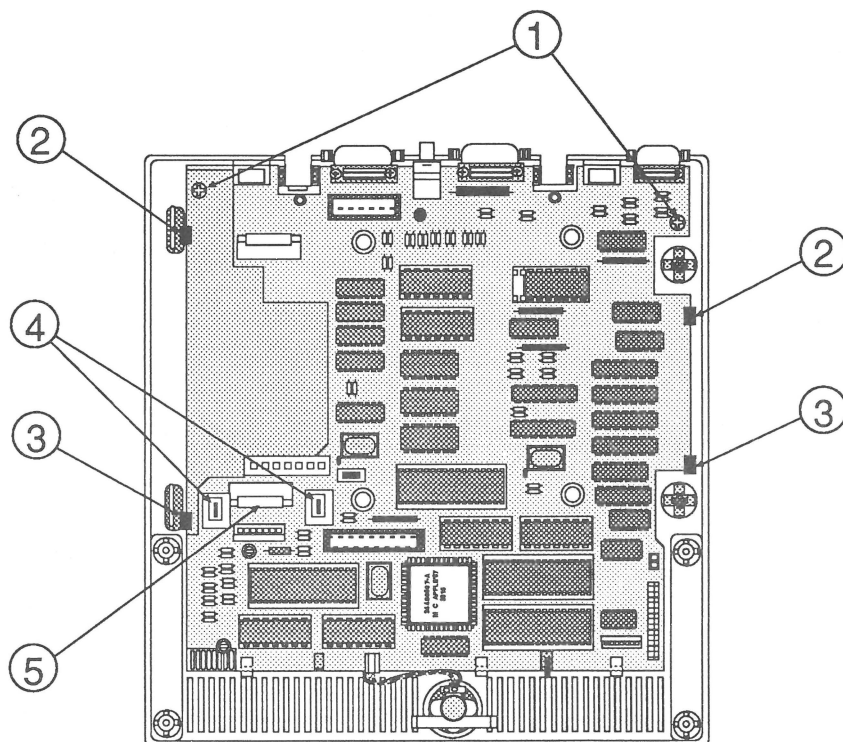

FIGURE 11

3. Remove the two Phillips screws (Figure 11, #1) that secure the logic board to the bottom case.
4. While **carefully** lifting the rear edge of the logic board, release the two rear logic board latches (Figure 11, #2).
5. Continue lifting the logic board and release the two front logic board latches (Figure 11, #3).
6. Continue to lift the rear of the logic board far enough for the logic board to clear the two power supply posts (Figure 11, #4) and the front latch (Figure 11, #5).

CAUTION: Don't lift the logic board too far, or you could break the bottom case clips.

7. Remove the logic board.

Replace

1. Place the logic board in position in the bottom case. Make sure the front of the logic board is under the three clips (Figure 12, #1) in the bottom case. The tab in the bottom case should also be in the slot (Figure 12, #2) cut in the logic board.

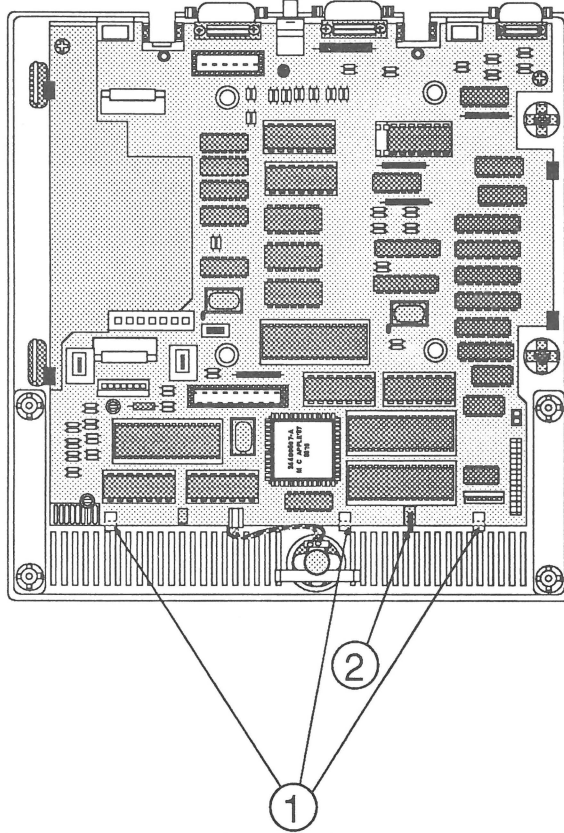

FIGURE 12

2. Lower the logic board into the bottom case and press the board down near each latch.
3. Replace the two logic board screws.
4. Connect the speaker cable to logic board connector J10.
5. Replace the power supply, disk drive, keyboard, and top case.

□ SPEAKER

Materials Required

None

Remove

1. Remove the top case.
2. Lift the keyboard and **gently** place it upside-down on the disk drive and power supply.

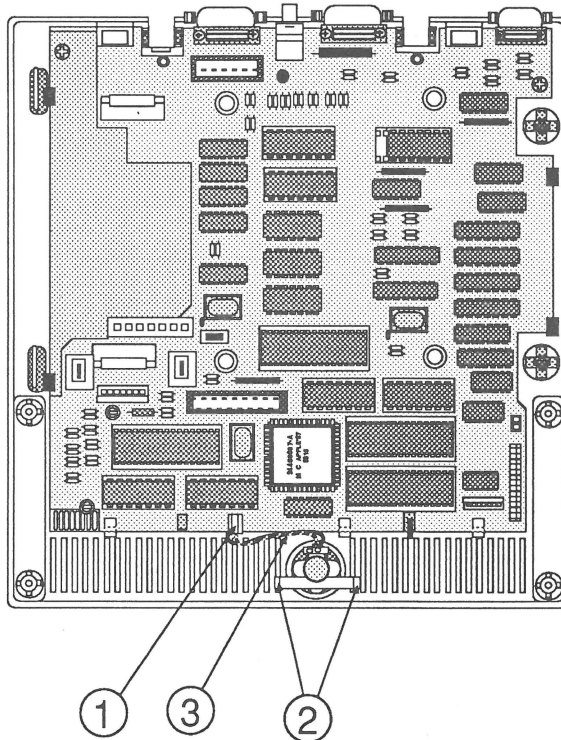

FIGURE 13

3. Disconnect the speaker cable from logic board connector J10 (Figure 13, #1).
4. Press in on the two tabs of the speaker snap (Figure 13, #2). Remove the snap.
5. Remove the speaker.

Replace

1. Place the speaker in position in the bottom case. The speaker wires should be coming from the bottom of the speaker (as shown in Figure 13, #3).

2. Replace the speaker snap. The half-oval opening in the snap should be against the speaker.
3. Connect the speaker cable to logic board connector J10.
4. Place the keyboard in position on its four support posts.
5. Replace the top case.

Apple IIc Plus

Section 3 – Diagnostics

□ CONTENTS

3.2	Introduction
3.2	Things to Remember
3.2	Before You Begin
3.2	Setting Up
3.3	While Testing
3.4	Built-In Diagnostic
3.4	Running the Diagnostic
3.4	Results
3.5	Apple IIc Plus Diagnostic
3.5	Main Menu
3.6	Choose Tests
3.8	Options
3.9	Special
3.9	Running the Diagnostics
3.13	Test Failures

Note: If a step is underlined, detailed instructions for that step can be found in Section 2, Take-Apart.

□ INTRODUCTION

This section describes general procedures for using the *Apple IIc Plus Diagnostic*. This diagnostic allows you to select the tests you wish to run and the order in which you wish to run them. It also allows you to run a continuous test, which is valuable for pinpointing the causes of intermittent failures.

□ THINGS TO REMEMBER

Before You Begin

1. **Make a backup diskette before beginning!** When testing a defective Apple IIc Plus, it is possible to erase and damage sections of the diskette. Use *System Utilities* (revision 2.1.1 or higher) to make the backup copy.
2. Before you boot the diskette-based diagnostics, run the built-in diagnostics.
3. The diagnostic can be run from either the internal disk drive or an external UniDisk 3.5 or Apple 3.5 Drive.

Setting Up

1. If you are going to select the **Serial External Test**, the loopback cable must be installed.
2. To select a test, type the letter or use the arrow keys until the name of the test is highlighted; then press <Return>.
3. When chosen, each test displays a number (1, 2, 3, etc.). This number indicates the order in which the tests will be performed.

4. To deselect a test, type the letter or use the arrow key until the name of the test is highlighted; then press the <Delete> key. The test sequence numbers displayed will be corrected automatically. To deselect all tests, press <Open-Apple> and <Delete>.
5. To access the **Help** screen, hold down <Shift> and <Open-Apple> and press ?.

While Testing

1. Where input is required to start the next test (after video tests, for example), press <Space>.
2. To abort any test, press <Escape>. The testing will stop upon completion of the test in progress.
3. If you select the looping function and are performing the **Serial External Test** without the loopback cable installed, you will receive an error code.
4. When running the Character Generator Test and using a ColorMonitor IIc (AppleColor™ Monitor IIc), the video display shifts left and right and toggles between color and monochrome. (This is the normal result of the method used to display the Character Set Test.)

To make the display easier to view, depress the White Only switch during the Character Generator Test, and release the switch during all other tests.

□ BUILT-IN DIAGNOSTIC

Before you boot the diskette-based diagnostics, run the built-in diagnostic. This will verify that the RAM, ROM, MMU, and IOU are functioning correctly.

Running the Diagnostic

To run the built-in diagnostic, hold down the <Open-Apple> and <Closed-Apple> keys while turning on the power. (To run them when the power is already on, hold down the <Control><Open-Apple><Closed-Apple> and <Reset> keys. Release the <Reset> key first, then the other keys.)

The screen will display various patterns and colors for approximately one minute while the RAM, ROM, MMU, and IOU circuitry on the logic board are tested.

Results

The results, shown in the center of the display, will be either **System OK** (accompanied by a high-toned beep) or the name of the failed component (with a low-toned beep).

Test Passed

If you can access the built-in diagnostics and you receive the message **System OK**, continue with this section.

Test Failed

If you cannot access the built-in diagnostics or you receive a message other than **System OK**, replace the logic board and try again.

□ APPLE IIc PLUS DIAGNOSTIC

Materials Required

Apple IIc Plus Diagnostic diskette
Video display and cable
Serial loopback cable (required for Serial External Test)
AppleMouse™ IIc (optional)
Hand Controllers II (optional)
Joystick II (optional)

Main Menu

The *Apple IIc Plus Diagnostic* main menu is shown below. A brief description of each menu item follows.

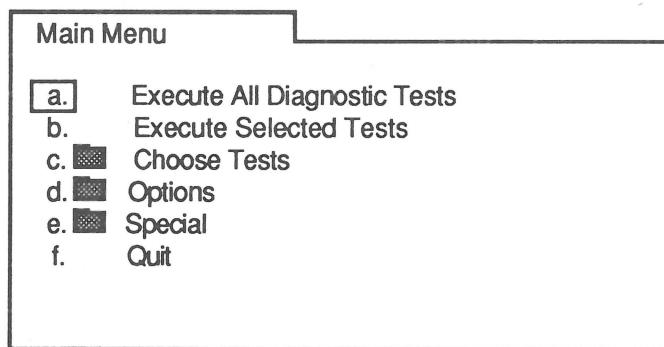

Execute All Diagnostic Tests – Runs the standard tests for the Apple IIc Plus.

Execute Selected Tests – Runs the tests selected in **Choose Tests**.

Choose Tests – Contains all the tests that can be selected for the Apple IIc Plus. Used to select one or more tests for customized testing.

Options – Contains various selections that allow you to control how the tests are run.

Special – Contains selections for keeping track of errors generated, for saving a test sequence, and for loading a test sequence from a diskette.

Quit – Stops all testing and reboots the system.

Choose Tests

The Choose Tests folder is shown below. A brief description of each menu item follows.

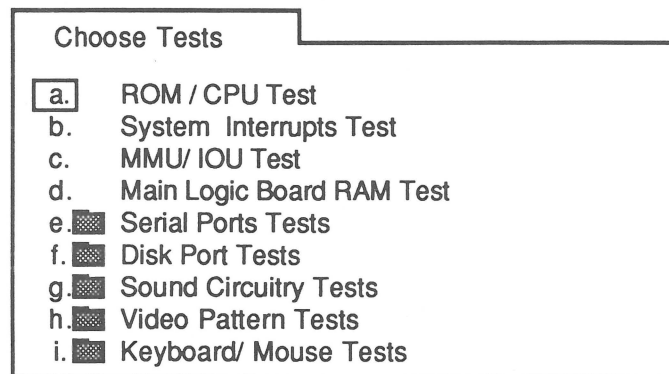

ROM/CPU Test – Checks the firmware ROM and microprocessor chip.

System Interrupts Test – Checks that interrupts are functioning correctly.

MMU/IOU Test – Checks the Memory Management Unit and the Input/Output Unit.

Main Logic Board RAM Test – Checks the 128K of RAM on the logic board.

Serial Ports Tests:

- **Serial Internal Test** – Checks the logic board circuitry that handles the serial ports.
- **Serial External Test** – Checks the serial ports to be sure they are sending and receiving data correctly. (A loopback cable is required.)

Note: If the loopback cable is not installed when performing the Serial External Test in continuous mode, the diagnostic will not inquire whether the loopback cable is installed and will record a failure. **Before** replacing the logic board, connect a known-good loopback cable and rerun the test.

Disk Port Tests:

- **Disk Port Test** – Checks the drive circuitry on the logic board for all 3.5- or 5.25-inch drives that are attached to the system. The diskette in the drive being tested must be ProDOS[®] formatted and the drives to be tested must be attached to the computer when the power is turned on.

Sound Circuitry Tests:

- **Speaker Tone Test** – Checks the speaker by playing a sequence of beeps.

Video Pattern Tests:

- **Color Bar Test** – Displays vertical color bars with the name of each color below.
- **Character Generator Test** – Displays the full character set.

Note: When running the Character Generator Test and using a ColorMonitor IIc (AppleColor Monitor IIc) the video display shifts left and right and toggles between color and monochrome. (This sequence is the normal result of the method used to display the Character Set Test.)

To make the display easier to view, depress the White Only switch during the Character Generator Test, and release the switch during all other tests.

- **80/40 Column Text Test** – Displays 15 lines of characters. First, 80 columns are displayed. After pressing the space bar, 40 columns are displayed.
- **Low Resolution Graphics Test** – Displays both pages (one and two) of low-resolution graphics with bars at the top of the screen.

...Continued on next page

- **High Resolution Graphics Test** – Displays both pages (one and two) of high-resolution graphics using a grid of 9 vertical lines intersected by 8 horizontal lines.
- **Double High Resolution Graphics Test** – Displays a grid of 18 vertical lines intersected by 8 horizontal lines.

Keyboard/Mouse Tests:

- **Keyboard Test** – Displays a keyboard layout. The instructions are given at the bottom of the screen.

Note: If you select the Keyboard Test under continuous mode, the diagnostic will flash the "Keyboard Test" message, increment the iterations counter, and never perform the keyboard test. You should not run the keyboard test in continuous mode.

- **Mouse Test** – Displays a pointer that can be moved around the screen and a box that indicates whether the mouse button is pressed or not.
- **Joystick/Paddle Test** – Displays a pointer that can be moved around the screen and a box that indicates whether the joystick/paddle buttons are pressed or not. If testing paddles, verify that both reach the full range possible (0-FF).

Options

When the **Options** folder is open, the following selections appear on the screen.

- **Loop Tests Until ESC Is Pressed**
- **Continue On Error Until ESC**

If an option is selected, a check mark appears beside the item. To deselect an option, just select the same option again.

Special

The following selections appear when the **Special** folder is opened.

- **Display Error Log** – Displays the names of the tests that have failed since the last clearing of the error log (up to 255 names).
- **Clear Error Log** – Erases the error log from RAM.
- **Clear Testing Status Line** – Clears the iterations and failure counts displayed on the main menu.
- **Display Current System Status** – This indicates the type of system, the ROM version, the amount of memory available, and whether a memory expansion card is installed, and if so, how much memory it contains.
- **Load Selected Test Sequence from Disk** – This will load a previously saved test sequence. The sequence can then be executed.
- **Save Selected Test Sequence to Disk** – This will save the tests you have selected under "Choose Tests" to the test diskette. It does not save selections made under "Options."

When any of these items is selected and <Return> is pressed, the action is performed.

Running the Diagnostics

The diagnostic program can be configured in various ways. All the tests can be run in their automatic sequence, or selected tests can be looped or run in an order you specify.

The diagnostic also has the ability to execute a test selection sequence that has been saved to the test diskette. Saved test sequences make it easier to test specific items that require nonstandard tests (see "Customized Tests").

Standard Test

1. Install the serial loopback cable, if available. If the cable is not available, type N when the diagnostic asks you if it is installed. Testing will continue.
2. Insert the *Apple IIc Plus Diagnostic* into either the internal or external disk drive. To run the diagnostic from the internal disk drive, turn on the computer. To run the diagnostic from an external drive, leave the internal drive door open.
3. Type the letter a or use the arrows to highlight **Execute All Diagnostic Tests**, and press <Return>.

To continue after certain tests (for example, Speaker or Video Patterns), press <Space>.

If an error is encountered, the testing will stop and an error message will be displayed in an alert box. Refer to "Test Failures" at the end of this section for the appropriate actions to perform.

4. On completion, the message **Testing finished** will be displayed in the alert box.

Customized Test

1. If you are going to test the serial ports, install the serial loopback cable.
2. Insert the *Apple IIc Plus Diagnostic* into either the internal or external disk drive. To run the diagnostic from the internal disk drive, turn on the computer. To run the diagnostic from an external drive, leave the internal drive door open.
3. Type the letter c or use the arrows to highlight **Choose Tests**, and press <Return>.
4. From this menu, use the letters or arrows to highlight the first four tests (if desired), and press <Return> to select them.

Use the letters or arrows to highlight the other test folders and press <Return> to display them. Use the letters or arrows to highlight the tests you wish to run from each folder, and press <Return> to select them.

Saving and Loading
Test Sequences

If you wish to deselect a test, use the letters or arrows to highlight the test and press the <Delete> key. To deselect all tests, press <Open-Apple> <Delete>.

5. To save your customized test sequence, return to the main menu, and select **Special**. Select **Save Selected Test Sequence to Disk** and press <Return>.

You now have the selected test sequence saved on the diskette. The sequence may be loaded later using **Load Selected Test Sequence From Disk**.

6. On completion, return to the main menu, select **Execute Selected Tests**, and press <Return>.

To continue after certain tests (for instance, speaker or video patterns), press <Space>.

If an error is encountered, the testing will stop and an error message will be displayed in an alert box. Refer to "Test Failures" at the end of this section for the appropriate actions to perform.

7. On completion, the message **Testing Finished** will be displayed in an alert box.

Continuous
Test

A continuous test is possible with all but the Keyboard/ Joystick Tests. Select the tests you wish to loop by following the instructions under "Customized Test" (see above). Follow the steps below to run a continuous test.

1. After the diagnostic is configured, return to the main menu and select **Options**.
2. Select **Loop Tests Until ESC Is Pressed**.

A check mark should appear indicating what has been selected.

3. Selecting **Continue on Error Until ESC** will cause the diagnostic to continue running regardless of an error until <Escape> is pressed. If you wish the diagnostic to stop on an error, make sure this option is not checked.

Errors will be logged to RAM.

4. Return to the main menu; select **Execute Selected Tests** and press <Return>.

The tests will run continuously (depending on your selection in step 3) until an error is encountered or <Escape> is pressed.

If you press <Escape> to stop the testing, you can then check for error codes by selecting **Special** followed by **Display Error Log**.

Highlight either the video display or the printer for a listing of the errors encountered.

5. If you are going to run the test again, be sure to clear the error log and the status line and to reselect **Loop Tests Until ESC Is Pressed** before returning to the main menu.

□ TEST FAILURES

When a test fails, a message will be displayed indicating which test failed. The following is a list of the tests, along with the recommended solution for each test failure.

Failed Test

Solutions

- *ROM/CPU* – Replace logic board.
- *System Interrupts* – Replace logic board.
- *MMU/IOU* – Replace logic board.
- *Main Logic Board RAM* – Replace logic board.
- *Serial Internal* – Replace logic board.
- *Serial External*
 1. Verify that the loopback cable is installed and securely connected.
 2. Exchange loopback cable.
 3. Replace logic board.
- *Disk Port*
 1. Verify that the diskette is inserted and that the drive door is closed.
 2. Verify that the diskette is not write protected.
 3. Try a different diagnostic diskette.
 4. Replace disk drive.
 5. Replace logic board.
- *Speaker Tone*
 1. Check volume setting.
 2. Verify that the speaker connector is securely attached to logic board connector J10.
 3. Replace speaker.
 4. Replace logic board.

...Continued on next page

Failed Test

Solutions

- *Keyboard*
 1. Rerun test to verify results.
 2. Replace keyboard.
 3. Replace logic board.

- *Mouse*
 1. Check mouse connections.
 2. Exchange mouse.
 3. Replace logic board.

- *Joystick/Paddle*
 1. Check joystick/paddle connections.
 2. Exchange joystick/paddle.
 3. Replace logic board.

Apple IIc Plus

Section 4 – Troubleshooting

□ CONTENTS

4.2	Introduction
4.2	General Information
4.2	How to Use the Symptom Charts
4.3	Symptom Charts
4.3	Video Problems
4.3	Drive Problems
4.4	Peripheral Problems
4.4	Miscellaneous Problems

Note: If a step is underlined, detailed instructions for that step can be found in Section 2, Take-Apart.

□ INTRODUCTION

General Information

These procedures provide guidelines for troubleshooting the Apple IIc Plus personal computer using the following tools:

- *Apple IIc Plus Diagnostic*
- Symptom Charts

Remember to follow basic ESD precautions when troubleshooting.

How to Use the Symptom Charts

The *Symptom Charts* describe symptoms and appropriate steps to correct the failure.

When swapping out modules, remove the suspected faulty module and replace it with a known-good spare module from your service stock. If the problem still occurs, remove the replacement module, reinstall the original module in the IIc Plus, and try swapping out the next module on the list. Repeat the procedure until the problem no longer occurs. The module you replaced just before the problem disappeared is the faulty one. As a final check of the system, run the *Apple IIc Plus Diagnostic*.

□ SYMPTOM CHARTS

WARNING: *Be sure the power is off before installing or removing any modules or components, or before connecting or disconnecting any peripheral devices. Failure to do so may result in damage to the computer, module, components, and/or peripheral.*

Video Problems

Symptom

Solution

- *No video*
 1. Check contrast and brightness settings on the monitor.
 2. Check video cable connections.
 3. Replace video cable.
 4. Replace logic board.

- *Random monitor display*
 1. Replace logic board.
 2. Replace keyboard.

Drive Problems

Symptom

Solutions

- *Will not boot*
 1. Replace disk drive.
 2. Replace logic board.

- *No disk access*
 1. Replace logic board.
 2. Replace disk drive.

- *Continuous disk access*
 1. Replace disk drive.
 2. Replace logic board.

Peripheral Problems

Symptom

Solutions

- *Mouse problems*
 1. Replace mouse.
 2. Replace logic board.
- *Printer prints garbage*
 1. Verify configuration of printer port.
 2. Verify configuration of printer option switches.
 3. Verify that the correct cable is being used.
 4. Replace logic board.

Miscellaneous Problems

Symptom

Solutions

- *No power*
 1. Replace power supply.
 2. Replace logic board.
- *No audio*
 1. Check volume setting.
 2. Check speaker connection.
 3. Replace logic board.
 4. Replace speaker.
- *No beep or message; random characters on display; disk drive does not come on*
 1. Replace logic board.
 2. Replace power supply.
- *AppleSoft BASIC errors*
 - Replace logic board.
- *Stuck keys*
 - Replace keyboard.
- *Programs run erratically, crash often*
 1. Replace disk drive.
 2. Replace logic board.

Apple IIc Plus

Illustrated Parts List

☐ CONTENTS

IPL.3 Finished-Goods Assembly (Figure 1)

The figures and lists in this section include all piece parts that can be purchased separately from Apple for the Apple IIc Plus, along with their part numbers. These are the only parts available from Apple. Refer to your *Apple Service Programs Manual* for prices.

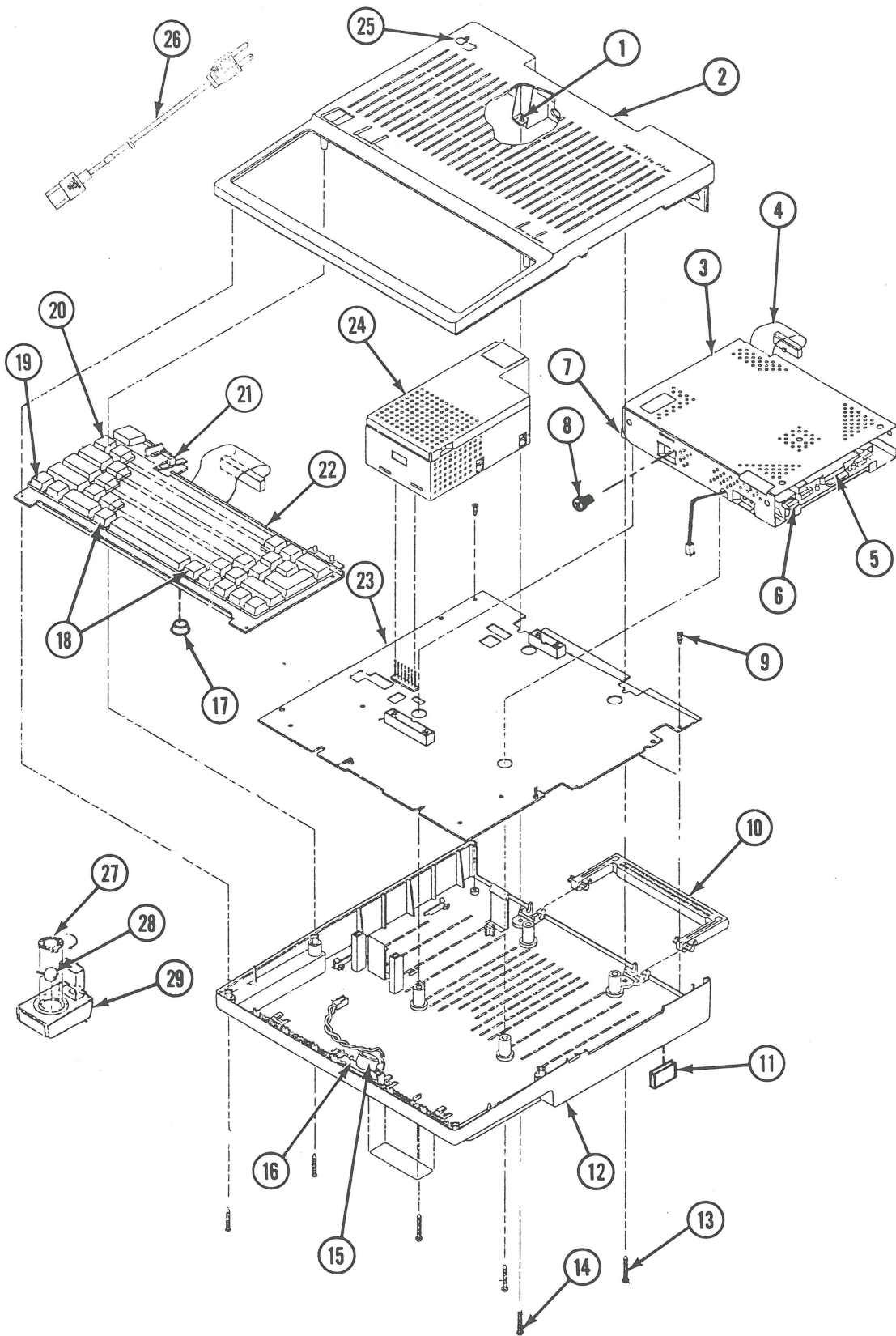

FIGURE 1

□ **FINISHED-GOODS ASSEMBLY (Figure 1)**

<u>Item</u>	<u>Part No.</u>	<u>Description</u>
1	835-0176	U-Type Nut
2	612-5025	Top Case
3	805-0928	Shield, Disk Drive Top
4	590-0383	Cable, Internal Disk Drive
5	661-0345	800K Mechanism, Apple 3.5 Drive
6	865-0867	Eject Button Assembly
7	805-0927	Shield, Disk Drive Bottom
8	460-3400	Screw, Disk Drive Shield
9	430-1029	Screw, Tap 4-20 x .250
10	865-0055	Platinum Handle
11	865-0024	Platinum Foot
12	815-0948	Bottom Case
13	400-1612	Screw, 6-32 x 3/4
14	430-1030	Screw, Tap 4-14 x .750, PN CRS Rec. A
15	600-0349	Speaker
16	815-1084	Speaker Snap
17	865-0003	Rubber Feet (Total of 5)
18	076-0209	Low-Profile Keyswitch
19	970-1263	Locking Alps Keyswitch
20	658-7101	Keycap Set
21	937-0031	Volume Control Switch
	815-1085	Volume Control Knob
22	661-0419	Keyboard
23	661-0418	Logic Board
24	661-0420	Internal Power Supply
25	825-1256	Logo
26	590-0380	AC Power Cable
27	815-0409	Mouse Ball Retainer
28	699-8001	Rubber-Coated Mouse Ball
29	661-0400	Platinum Apple Mouse